

Conducted EMC Filters for Flex Board Mounted Power Supplies

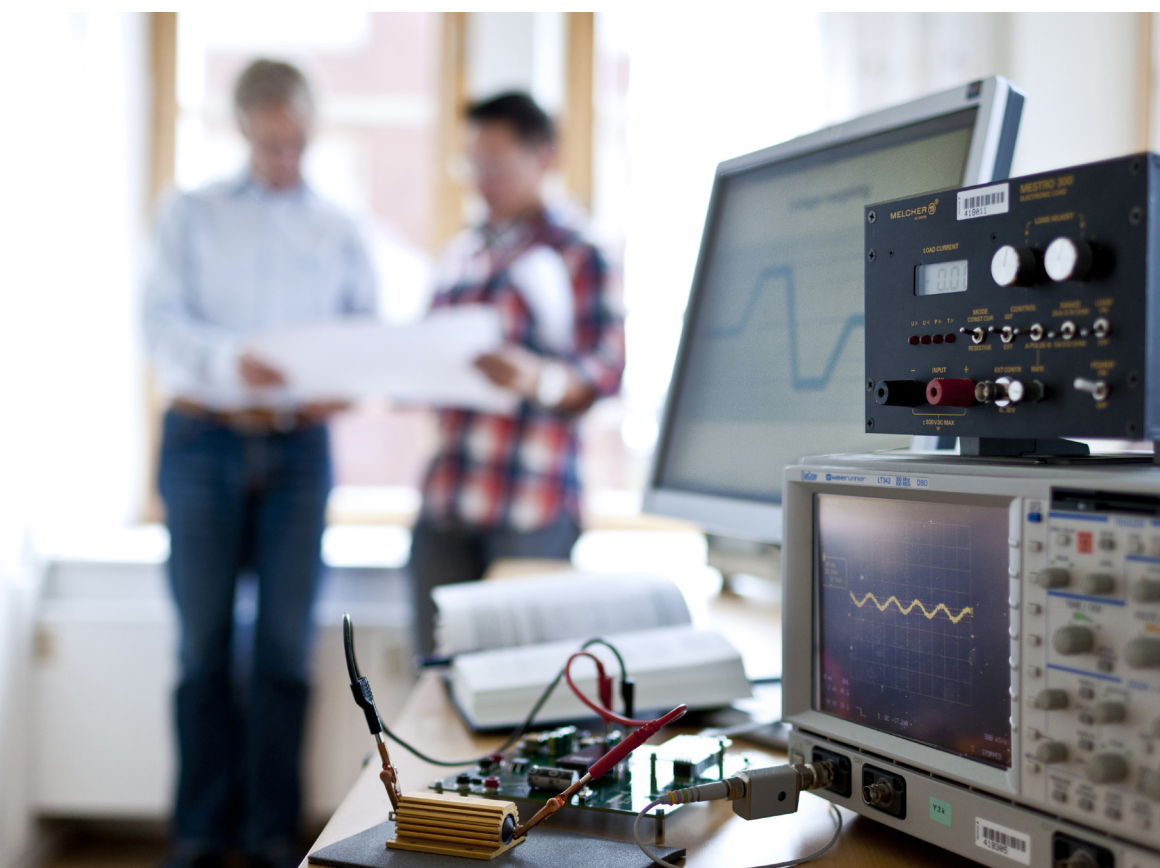

Abstract

EMC compliance is an important aspect of system design that can sometimes be a confusing issue. This confusion can be due to a misunderstanding of the requirements or be based on the belief that meeting EMC requirements when using high frequency switching converters is complicated and expensive. This design note is intended to alleviate this situation by showing that Flex board mounted power supplies, BMPS, can be easily integrated into a wide range of electronic systems while meeting the system level EMC requirements. It will be shown that the external filtering required is simple to design and provides high levels of performance in a cost effective fashion.

A brief overview of the most often encountered system EMC regulations and design goals will be presented. This will be followed by a discussion of how Flex designs and tests all board mounted power supplies so that the system designer is provided with the proper information and tools to streamline the system EMC design process. Specific filter topologies and design guidelines will then be presented for both 3 wire and 2 wire DC/DC converter implementations. A design example will specifically show how this recommended approach allows compliance to class B conducted emission requirements with a healthy design margin.

EMC overview

EMC standards are needed to insure that, in a given type of environment, various pieces of end-use equipment will perform satisfactorily without interfering with each other. This potential interference can occur due to either electromagnetic radiation or to noise conducted over power lines and other interconnections. International standards organizations have formulated widely accepted criteria that must be met by electrical equipment manufacturers in order to be in compliance for operation in a defined environment. Such environments include military, medical, industrial and domestic including office and communications equipment. Industrial and domestic are the two most common application areas, and the EMC requirements are stricter for domestic applications. Consequently, most manufacturers design and verify compliance to the domestic requirement which then will also allow usage in an industrial application.

The EMC standards are based on practical limits obtained from years of field experience and are consequently fairly robust in terms of insuring interoperability between equipment that meet the requirements.

The types of testing that may be required include conducted noise on input and output cables, noise radiated from the unit, and immunity from sources such as lightning strikes, power line voltage transients, electrostatic discharge (ESD) and electromagnetic fields.

In order to meet these EMC requirements the hardware design of most equipment will need to include dedicated components as well as good engineering design practices.

Components typically used to address EMC compliance include:

- Capacitors
- Ferrite beads
- EMC filters with inductors and capacitors
- Voltage transient limiters such as zeners, transorbs, varistors, and gas discharge tubes

EMC design practices include:

- Use of groundplanes
- Proper grounding and bonding techniques
- Use of shielding in critical areas
- Awareness of high energy signals that could create interference

Rather than describing all the standards and design requirements, we will focus on the most commonly used criteria for many system designs, the EN55022 and FCC domestic Class B conducted emissions requirements. This will typically be the system level requirement that is most affected by the usage of DC/DC converters, and compliance will insure operability in both domestic and industrial environments. Fortunately this requirement is easily met when using Flex board mounted power supplies in conjunction with the applications guidelines provided herein as well as in other Flex documentation.

The EN55022 conducted emissions standard places an upper limit on the voltage conducted from the power input wires of the equipment back into the power source, with the source terminated in a standardized impedance of 50 ohms. The voltage limit varies with frequency, and is specified from 150 kHz to 30 MHz. The requirements of EN55022, which is used in much of the world, are slightly different from the FCC standards used within the United States. They are both measured with the same test methodology, however, so that data collected can be applied to both standards. The EN55022 requirements are slightly stricter, so that for practical purposes meeting this standard will also result in meeting the FCC requirements. The remainder of this design note will therefore be restricted to designing for the EN55022 Class B requirement, which is shown in Figure 1 along with the FCC limit. Two limits are shown for EN55022, one labeled “quasi-peak” and one labeled “average”. These refer to two standardized detector response characteristics in the EMC test spectrum analyzers. In order to comply with the standard both limits must be met, but typically meeting one of them will also assure compliance with the other. In addition, meeting the “average” EN55022 limit will also insure that the FCC limit is met, due to qualifying language in the FCC standard. Therefore, the EN55022 Class B “average” limit will be used in this design note as the design and compliance criterion.

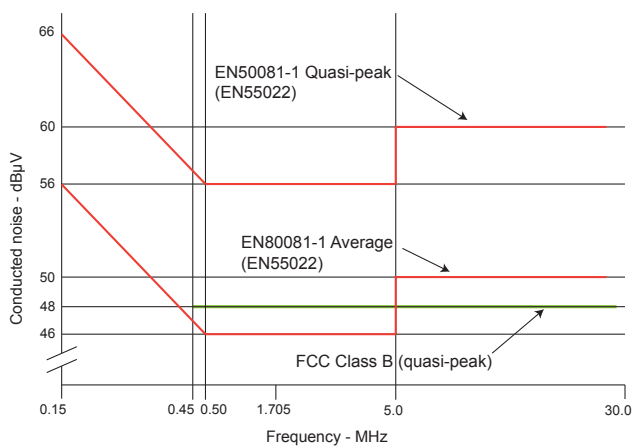

Figure 1 - Limit curve example

EMC Strategy at Flex Power Modules

EMC requirements, such as the common EN55022 Class B specification discussed above, apply at the system level and not to individual components such as board mounted power supplies. Nevertheless, Flex board mounted power supplies are designed and supported so that the system designer can easily assure compliance to the required EMC specifications.

EMC is a prime consideration in the hardware design of Flex Power Modules.

The input section of each DC/DC converter contains a basic PI section conducted emissions filter that is a substantial help in meeting system level requirements. The physical layout and packaging are optimized to enhance the EMC performance. For example, extensive ground planes are used near switching circuitry to minimize radiated noise and to increase the immunity of the product from outside noise sources. The products are also designed to tolerate short-term input voltage transients over and above the specified steady state limits.

Applications information is also readily available to make system level EMC compliance easier. The technical specification of each product contains specific recommendations for system-level conducted emissions filtering suitable in terms of meeting EN55022 Class B requirements. Flex Power Modules Design Note 009 is also available, and contains extensive information on the design and performance of conducted emissions filtering for a broad range of product types.

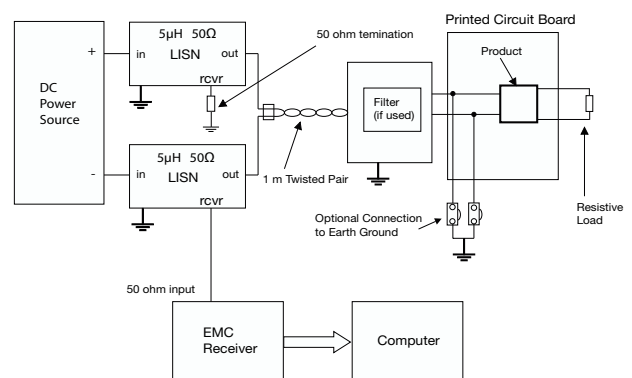

Figure 2 - Test Set Up

Flex Power Modules maintains an EMC lab for the purpose of measuring the EMC performance of its products. This facility is used, for example, to design and characterize the performance of the conducted emissions filters suggested in the product technical specification and

in this design note. A diagram of the basic test setup used is shown in Figure 2. This arrangement adheres to the common industry standards for conducted emissions testing and provides accurate and reproducible results. Line Impedance Stabilization Networks (LISNs) are used to provide a known and stable source impedance when looking into the power source. A calibrated spectrum analyzer connected to a computer is used to collect and store the data. A photograph of the test facility is shown in Figure 3. The four rectangular blocks in the lower right of the picture are batteries that are being used as a power source to eliminate any potential confusion between noise produced by the device under test and that from the power source. The two large rectangular objects to the left of the batteries are the LISNs. The device under test is further to the left at the end of the twisted pair cable. A close up of the product being tested is shown in Figure 4.

From left to right in this photo are the load, the product and a conducted emissions filter. Note that all of the elements in the path from the power source to the load are physically located close to the grounded conductive top of the test bench. The spectrum analyzer used for the measurement can be seen in Figure 3 on the shelf above the batteries.

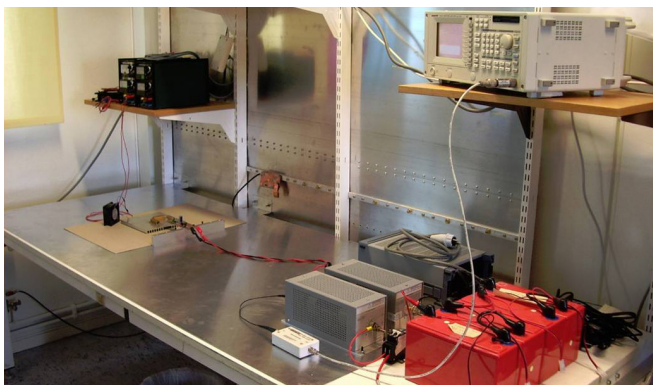

Figure 3 - Flex Power Modules Conductive Test EMC lab

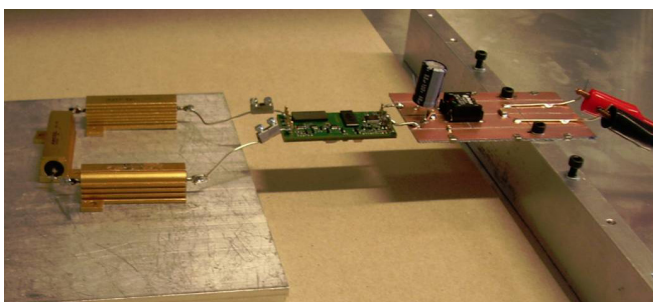

Figure 4 - Device Under Test, DUT

Conducted Emissions Filter Design Approach

EMC filter design is often thought to be an involved process entailing significant effort in circuit analysis, component selection and iterative cycles of testing and redesign. This indeed can be the case when working with new or unusual types of circuitry and systems. However, in the case of using standardized DC/DC power modules in typical systems intended for applications requiring compliance to EN55022 class A or B requirements the situation is much easier. Flex has extensive experience with such systems and, as previously discussed, fully characterizes all board mounted power supplies and supports them with

documentation that simplifies EMC compliance of the end product. We will here present generic conducted emission filter designs that will meet EN55022 Class B requirements when used with an Flex board mounted power supply. The design approach is to use simple filter topologies that will cover a broad spectrum of applications rather than expecting the system designer to do detailed optimization of unique filters for each specific configuration. Furthermore, these designs are intended for implementation with standard off-the-shelf components available from several sources at reasonable costs. No unique or custom components are required.

A conducted emissions filter must generally address two types of noise suppression, differential mode and common mode. Assume that the input power arrives via two wires called "power" and "neutral", and that both of these wires are isolated from chassis ground. A differential mode signal current flows into one wire and out of the other. Since the power and neutral wires are closely coupled this differential current is closely contained and does not tend to cause radiation to the outside world. An analogy would be a radio signal traveling through a transmission line – even though there can be significant voltage and current inside the line, the line does not radiate. Common mode signals occur when there is an in-phase voltage on both the power and neutral lines with respect to ground. These signals most commonly arise from high frequency current switching within the equipment, since power components have capacitance to ground that causes current to flow through this path. Common mode noise is often more difficult to control and will radiate since both of the wires are acting as one with no cancellation between them. Differential mode noise tends to be easier to filter, but both modes are addressed and effectively managed by the filters presented here.

Flex board mounted power supplies are used in systems with two basic types of DC input power distribution. A so called "3 wire" system is one in which there is both a positive and a negative DC input power conductor in addition to the chassis ground. A "2 wire" system uses the chassis ground as the only return for the DC power input conductor. These two types of systems require different EMC filter topologies, both of which

are addressed in the recommendations that follow.

The circuit shown in Figure 5 is a dual common mode filter designed for 3 wire systems. This filter can handle a broad range of input power up to 1000 W. The component ratings are scaled as a function of the system power as indicated in the figure. The differential mode capacitors, C1, C2, C3 and C8 are often referred to as "X capacitors". For reliability purposes the voltage rating of these capacitors should be above the maximum DC input voltage and twice the nominal DC input voltage. Capacitors C4, C5, C6 and C7 are common mode capacitors, often referred to as "Y capacitors". Because of safety considerations the voltage rating of these capacitors must be greater than the isolation voltage specification for the equipment. L1 and L2 are standard common mode inductors readily available from magnetic components suppliers, e.g. Pulse and Coilcraft. The catalogs of these suppliers will indicate the families of parts that are suitable for use with high frequency switching converters. An appropriate part can then be selected based on the maximum DC current of the system and the type of packaging desired. These common mode inductors do have leakage inductance so that the circuit will act as a differential mode filter as well. For systems with power requirements of 25 W or less, the filter can be simplified by using only one stage rather than two. In this case, only C1, C2, C4, C5, C8 and L1 will be required. Standard components are available so that this filter can be constructed with either thru-hole or SMT packaging.

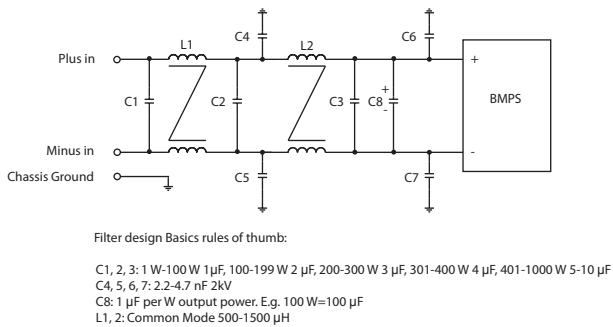

Figure 5 - Basic Dual Common Mode filter for 3 wire systems

The suggested filter for 2 wire systems, shown in Figure 6, is a dual section PI filter. In this case common mode inductors and the Y capacitors are not required and can be replaced by two terminal inductors and ceramic differential mode capacitors. The capacitors should have a voltage rating above the maximum DC input voltage and twice the nominal DC input voltage. The inductors are selected based on the maximum DC input current. For systems with power requirements of 25 W or less, the filter can be reduced to one stage rather than two, using only C1, C2, C5 and L1. With two wire systems special consideration must be given to minimizing the inductance in the filter ground connections. With either type of filter a ground plane type of

construction should be used in order to minimize radiation and to maximize the filter conducted emission performance and system noise immunity.

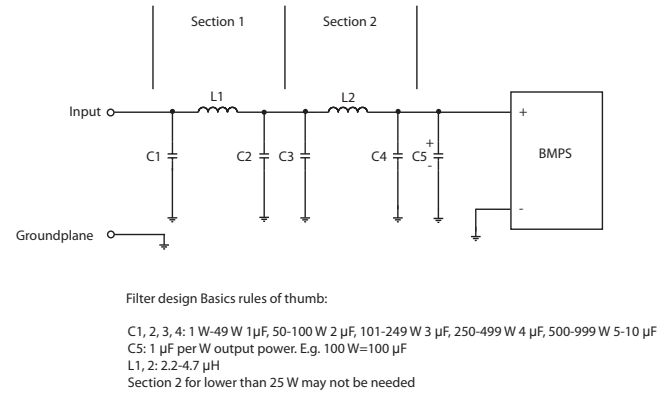

Figure 6 - Basic Two Wire filter

Implementation Example

The generic filter circuits presented above are easily adapted to specific system requirements. As an example the design of a 3 wire common mode filter for usage with an Flex PKJ4216 will be described. The PKJ4216 is a half brick module with an output voltage of 28 V and a maximum output power of 234 W. Its specified efficiency is 91.5%, resulting in a maximum input power of 256 W. This module is intended for usage with a nominal 48 V input power source, with an input voltage range of 35 to 75 Vdc. The maximum input current is therefore calculated using the 35 Vdc minimum input voltage as $256/35 = 7.3$ A. The common mode inductors L1 and L2 will need to have a current rating of at least 7.3A. The datasheets of the magnetic suppliers can then be used to select a standard common mode inductor with an inductance value between 500 and 1500 μ H and a current rating higher than 7.3 A, perhaps something in the range of 8 to 10 A.

The guidelines in Figure 5 will be used to select the capacitors. Since the power is in the range of 200 to 300 W, a standard value capacitor close to 3 μ F will be used for C1, C2 and C3. C8 is calculated to be about 256 μ F. In practice, a combination of one or more standard value capacitors would be used for C8 so that the total capacitance is within 20% of this value. Capacitors C1, C2, C3 and C8 will see a nominal voltage of 48 V and a maximum steady state voltage of 75 V. Capacitors with a 100 V rating would typically be used. Capacitors C4, C5, C6 and C7 are standard common mode Y capacitors and their value will not change as a function of the load power. They must have a voltage rating higher than the isolation voltage requirement of the equipment. The performance of a filter designed as above relative to the

EN55022 Class B “average” response limit is seen in Figure 7. The specification is met over the entire frequency range, with a minimum margin of about 3 dB at a few frequencies. The typical margin is approximately 20 dB, and the maximum margin 30 dB.

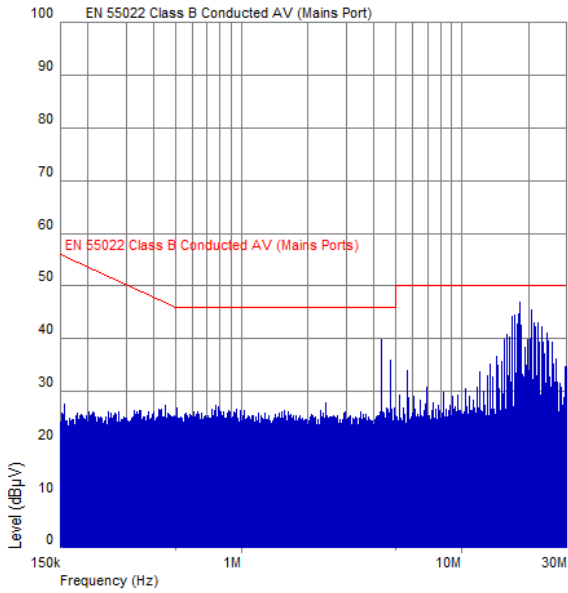

Flex DESIGN ADVISE

Conclusion

The seemingly complex EMC regulatory structure can be vastly simplified for the majority of systems when using standard board mounted power supplies. It has been shown that designing for EN55022 Class B requirements is an easy and predictable process when using Flex power modules along with their support documentation and the generic filter design guidelines in this design note. Suggested filter topologies and component values have been presented for both 3 wire and 2 wire input DC distribution systems. A design example was used to show that a 3 wire common mode filter designed in accordance with these guidelines successfully meets the EN55022 Class B requirement.

Formed in the late seventies, Flex Power Modules is a division of Flex that primarily designs and manufactures isolated DC/DC converters and non-isolated voltage regulators such as point-of-load units ranging in output power from 1 W to 700 W. The products are aimed at (but not limited to) the new generation of ICT (information and communication technology) equipment where systems' architects are designing boards for optimized control and reduced power consumption.

Flex Power Modules
Torshamnsgatan 28 A
164 94 Kista, Sweden
Email: pm.info@flex.com

Flex Power Modules - Americas
600 Shiloh Road
Plano, Texas 75074, USA
Telephone: +1-469-229-1000

Flex Power Modules - Asia/Pacific
Flex Electronics Shanghai Co., Ltd
33 Fuhua Road, Jiading District
Shanghai 201818, China
Telephone: +86 21 5990 3258-26093

The content of this document is subject to revision without notice due to continued progress in methodology, design and manufacturing. Flex shall have no liability for any error or damage of any kind resulting from the use of this document