

Reference Board BMR 481 P1E+

ROA 170 014

USER GUIDE

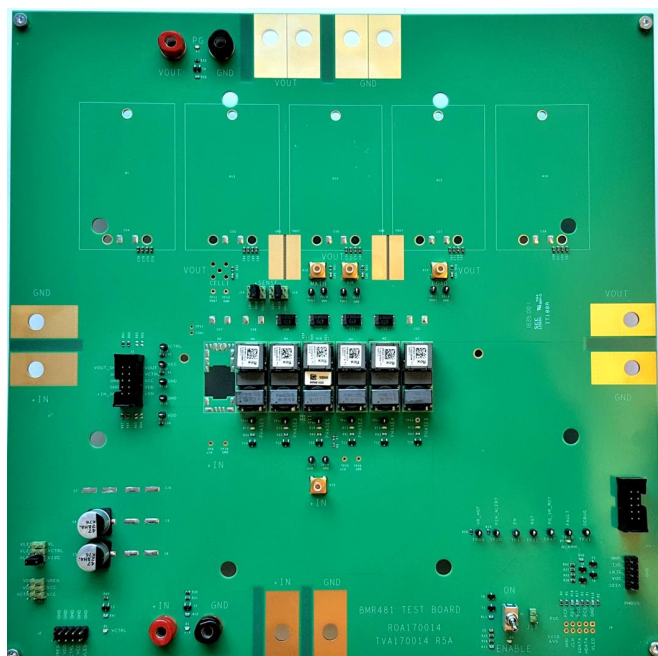

Copyright

© Flex 2018. All rights reserved

Disclaimer

No part of this document may be reproduced in any form without the written permission of the copyright owner.

The contents of this document are subject to revision without notice due to continued progress in methodology, design and manufacturing. Flex shall have no liability for any error or damage of any kind resulting from the use of this document.

Trademarks

All trademarks are properties of their owners.

Flex is the trademark of Flextronics International.

PMBus[™] is a trademark of SMIF, Inc.

Windows[®] and **Microsoft**[®] are the trademarks of Microsoft Corporation in the United States or other countries.

Contents

1	Introduction	4
1.1	How to contact Flex	4
1.2	Prerequisites.....	4
2	Reference Board ROA 170 014	5
3	Power-up and Power-down Instructions	7
3.1	Power-up instruction	7
3.2	Power-down instruction.....	7
4	Board Supplies	8
5	Address Resistor	9
5.1	Adjustment of address resistor.....	9
6	Phase Active LEDs	9
7	Test Points and Sense Locations	10
7.1	VIN/VOUT test points.....	10
7.2	Sense location jumpers.....	10
7.3	PWM test points.....	10
8	Additional Output Capacitance	11
9	Current Sense termination	11
10	Electronic loads	12

1 Introduction

This User Guide provides a brief introduction and instruction on how to use the Reference Board ROA 170 014 together with BMR 481 MAIN and SATELLITE modules of revision P1E and later.

1.1 How to contact Flex

For general questions or interest in our products, please contact your local sales representative. Contact details are available from our website:

<https://flex.com/expertise/power/scalable-power-modules>

1.2 Prerequisites

In order to operate the ROA 170 014 board the following is needed:

- Power supply 40-60 V.
- Power supply 5 V.
- BMR 481 MAIN (BMR 481 0021/002 P1E) and SATELLITE (BMR 481 0022 P1E) modules. The modules are soldered onto the board at delivery.
- The MAIN module is preconfigured for the number of SATELLITEs populated.
 - ROA 170 014/3 P6A is populated with 5 SATELLITEs and 1 MAIN.

2 Reference Board ROA 170 014

In Figure 1a and 1b the top and bottom side of the ROA 170 014 is shown.

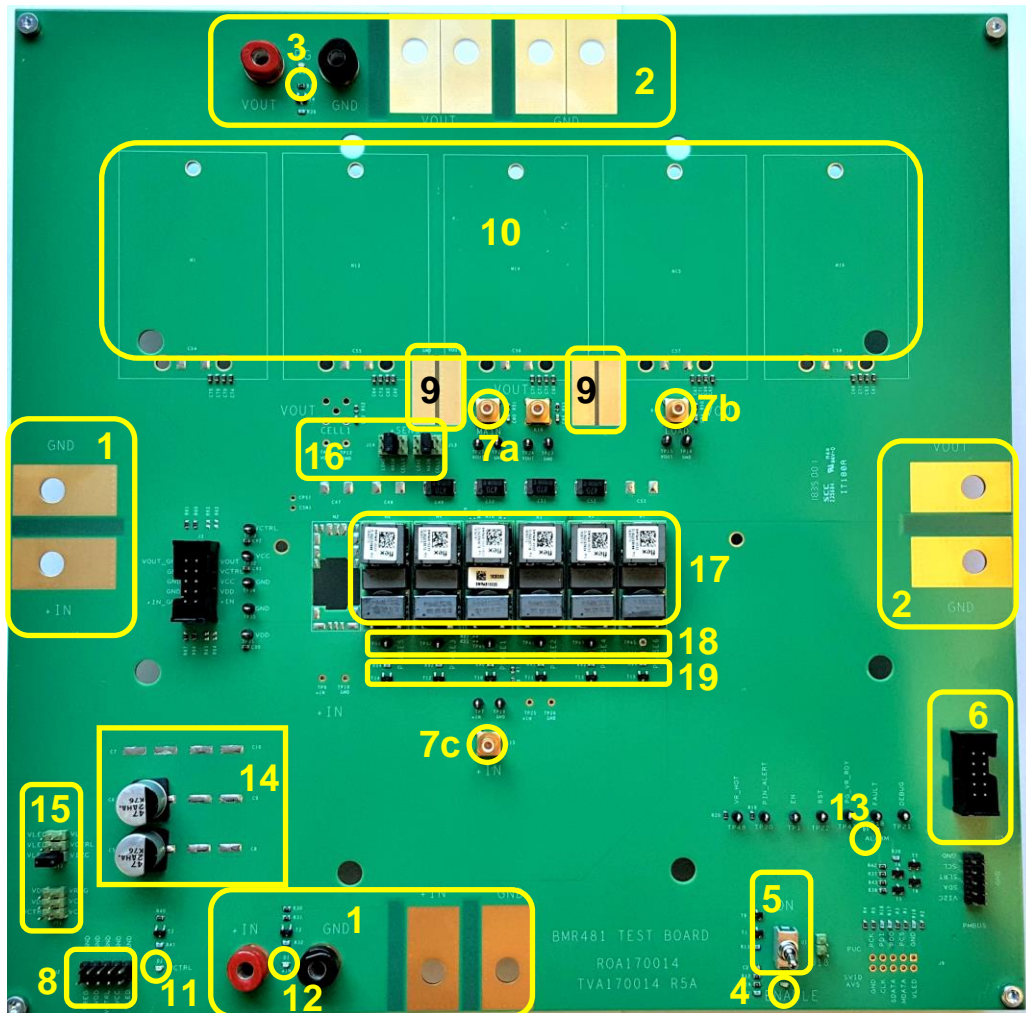

Figure 1a. ROA 170 014 (top side). Descriptions are found on next page.

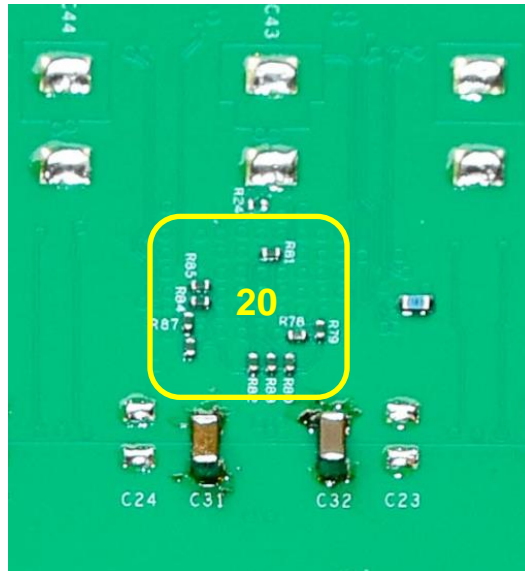

Figure 1b. ROA 170 014 (bottom side).

Position Description (Top Side)

- 1 Input voltage connectors.
- 2 Output voltage connectors.
- 3 Power Good LED.
- 4 Enable switch on LED.
- 5 ENABLE switch.
- 6 Connector for the PMBus-to-USB adaptor (KEP 910 17).
- 7 SMB Oscilloscope connectors for Vin and Vout, See Sec 7.
- 8 Connector for driver, controller and auxiliary supplies.
- 9 Space for additional output capacitors.
- 10 Positions for populating Flex electronic load, PuLS.
- 11 VCTRL power on LED.
- 12 Vin power on LED.
- 13 Fault detected and SALERT LED.
- 14 Space for additional input capacitors.
- 15 Supply option jumpers.
- 16 Sense location jumpers.
- 17 MAIN and SATELLITE modules.
- 18 PWM probing points.
- 19 Phase Active LEDs. See Sec 6.

Position Description (Bottom Side)

- 20 Resistors for termination of current sense – 0 Ohm resistor shall be mounted for un-populated SATELLITE positions. See Sec 9 for details.

3 Power-up and Power-down Instructions

3.1 Power-up instruction

- Make sure Enable switch is in OFF position
- Make sure jumpers are populated in J11 and J12 (position 15) to
 1. connect VDD and VCC
 2. connect VCTRL and VCC
 3. connect VLED and VCTRL

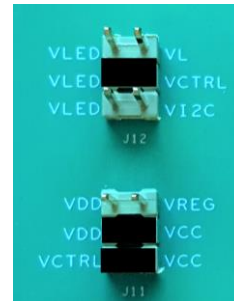

- Apply VCTRL = 5 V through connector J2 (position 8). The VCTRL voltage LED should give green light. This will now supply primary and secondary control of MAIN and SATELLITES, as well as controller and LEDs.
- Apply $V_{in} = 40-60V$ through connectors (position 1). The input voltage LED should give green light.
- Set Enable switch in ON position. The power good LED should now give green light, as well as the Phase Active LED for the MAIN.
- When measuring V_{out} , set sense location jumpers in position according to the V_{out} measurement points used (see section 7).

3.2 Power-down instruction

- Set Enable switch in OFF position
- Turn off V_{in}
- Turn off VCTRL

4 Board Supplies

Above input voltage VIN, supplies according to the Table 1 are used at the test board. By jumper connectors J11 and J12 (position 15 in Figure 1a) the supplies can be interconnected.

Supply	Description	May be jumped to	Supply connector
VCC	Secondary side control supply for MAIN and SATELLITEs	VDD ¹ , VCTRL	J2 (position 8)
VDD	Primary side control supply for MAIN and SATELLITEs	VCC ¹	
VCTRL	Supply for controller in MAIN	VCC ¹	
VLED	Supply of LEDs on test board	VCTRL ¹	
VL	Optional supply for electronic loads	VLED	
VI2C	Supply (3.3V) provided by PMBus-to-USB adaptor	VLED	J1 (position 6)

Table 1 Summary of supplies.

¹ This is the pre-configured jumper setting for ROA 170 014/3 P4A and ROA 170 014/4 P4A.

Note: If PMBus-to-USB adaptor (KEP 910 17) is connected to J1, VLED must not be jumped to VI2C and VCTRL at the same time (because then VCTRL will connect with VI2C supplied from adaptor).

5 Address Resistor

5.1 Adjustment of address resistor

To change the address, change the resistor shown in Figure 2.

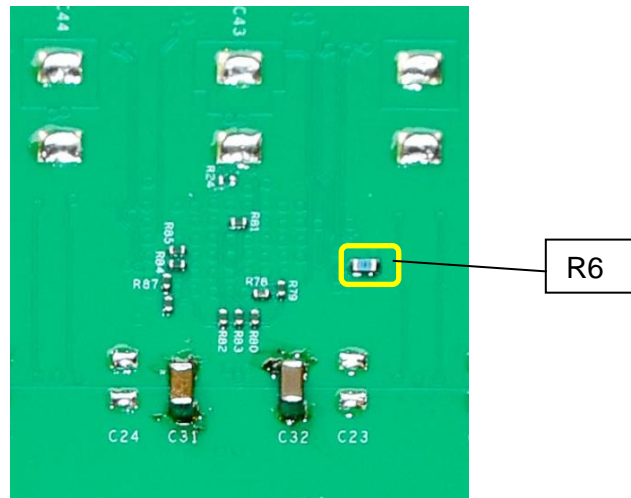

Figure 2 Address resistor position, R6, is shown in the picture.

Change resistors R6 (SA) to achieve the desired PMBus address for the MAIN module.

6 Phase Active LEDs

These LEDs (position 19) indicate the number of phases currently being used. Each LED will light up when the corresponding MAIN or SATELLITE is switching, i.e. when there is an active PWM signal.

MAIN = Phase 1. SATELLITEs = Phase 2-6.

7 Test Points and Sense Locations

7.1 VIN/VOUT test points

Input voltage should be measured at test points TP7/TP29/K15 (position 7c) which are connected directly to the VIN/GND pins of MAIN module (PHASE 1) at the Test board. Alternative test points are TP25/TP26, connected to VIN/GND pins of PHASE 2 at the Test board.

Output voltage can be measured at test points TP27/TP28/K16 (position 7a) which are directly connected to VOUT/GND pins of MAIN module (PHASE 1) at the Test board. Alternative test points are:

- TP15/TP16/K14 (position 7b), connected to VOUT/GND pins of center positioned electronic load (position 10).
- TP24/TP23/K18, connected to VOUT/GND pins of PHASE 2 at the Test board.

7.2 Sense location jumpers

Sense location jumpers in J13/J14 (position 16) must be correctly placed according to VOUT test points used:

- Use positions "MAIN" when measuring VOUT at TP27/TP28/K16.
- Use positions "LOAD" when measuring VOUT at TP15/TP16/K14.

If no jumpers are populated, internal sense resistors in MAIN module will be used.

7.3 PWM test points

PWM test points in position 18 can be used to probe a PWM signal to each MAIN or SATELLITE module, to see if it is currently switching or not.

8 Additional Output Capacitance

If additional output capacitance is desired, the possibility exists to mount extra electrolytic and/or ceramic capacitors, see Figure 3.

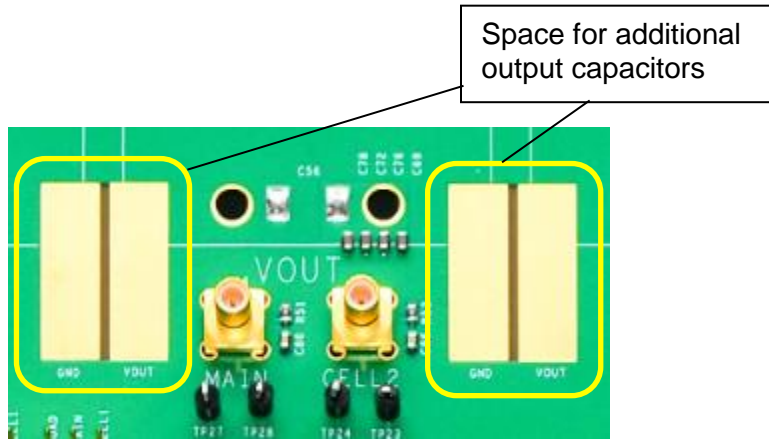

Figure 3 Space for additional output capacitors.

9 Current Sense termination

R78 - R87 (position 20) are used to terminate the current sense wire when SATELLITEs are not mounted. Which resistors to mount or un-mount is described in Table 2.

SATELLITE not mounted	Resistors to mount
PHASE2	R78, R79
PHASE3	R80, R81
PHASE4	R82, R83
PHASE5	R84, R85
PHASE6	R86, R87

Table 2 Mounting table of current sense termination resistors, R78 - R87.

10 Electronic loads

In order to perform load transient tests on the modules, up to 5 pcs of PuLS loads can be connected to the output of the board, see position 10 in Fig 1a.

The PuLS loads (ROA 128 5552/1) can be programmed for different transient loads and waveforms, see the technical specification for further information. They do not need to be soldered, the board is prepared for the use of sockets so the loads easily can be mounted.