



BMR320

8:1 fixed ratio digital IBC (400W)

BMR320 is based on an unregulated and non-isolated topology, and is intended for applications needing a lower voltage intermediate bus for improved system efficiencies such as AI and Cloud Computing.

BMR320 delivers an efficiency of 97.6% at half load, and offers a PMBus compatible digital interface, and is supported by our Flex Power Designer tool.

Up to 3 units can be used in parallel to supply an overall output power of up to 1080W.



Key features

- 8:1 fixed ratio IBC
- Small form factor
- Parallelable - up to 3 units
- Unregulated
- Non-isolated
- Digital interface with PMBus
- Excellent price/performance ratio

Soldering methods

- Pb Free SMD reflow

Target key electrical information

Parameter	Values
Input range	40 - 60V
Output voltage	5 - 7.5V
Output current continuous	60A at 54V _{in}
Output power continuous	400W

Mechanical

27.0 x 18.0 x 6.4 mm / 1.06 x 0.71 x 0.25 in

Application areas

- Designed for Artificial Intelligence (AI) applications

Product options

The table below describes the different product options.

Example: BMR320 1 0 00 /001						C	Definitions
Product family	BMR320						
Pin length options		1					0 = Pin length TBD 1 = SMD
Baseplate / HS option			0				0 = No baseplate
Other hardware options				00			00 = Standard variant 01 = TBD
Configuration code					/001		/001 = standard config. for 40-60 V _{in}
Packaging options						C	C = Tape on Reel H = hard tray, dry pack

For more information, please refer to Part 3 Mechanical information.

Part 1: Electrical specifications

Absolute maximum ratings

Stress in excess of our defined *absolute maximum ratings* may cause permanent damage to the converter. Absolute maximum ratings, also referred to as *non-destructive limits*, are normally tested with one parameter at a time exceeding the limits in the electrical specification.

Characteristics	min	typ	max	Unit
Operating temperature (T_{PI})	-40		85	°C
Storage temperature	-55		125	°C
Input voltage (V_{in})	-0.3		60	V
Isolation voltage (input to output)	0		0	V
5V V_{CC}	-0.3		5.5	V
Enable control pin voltage	-0.3		$V_{CC}+0.3$	V
PMBus pins	-0.3		$V_{CC}+0.3$	V

Reliability

Failure rate (λ) and mean time between failures ($MTBF=1/\lambda$) are calculated based on *Telcordia SR-332 Issue 4: Method 1, Case 3, (80% of I_{out_TDP} , $T_{PI}=40^{\circ}C$, Airflow=200 LFM)*.

	Mean	90% confidence level	Unit
Steady-state failure rate (λ)	108	142	nfailures/h
Standard deviation (σ)	26.3		nfailures/h
MTBF	9.24	7.04	MHr

Typical application diagram

Capacitor values are defined in the Electrical Specification tables. The EMI filter is defined in the EMC Part 2.

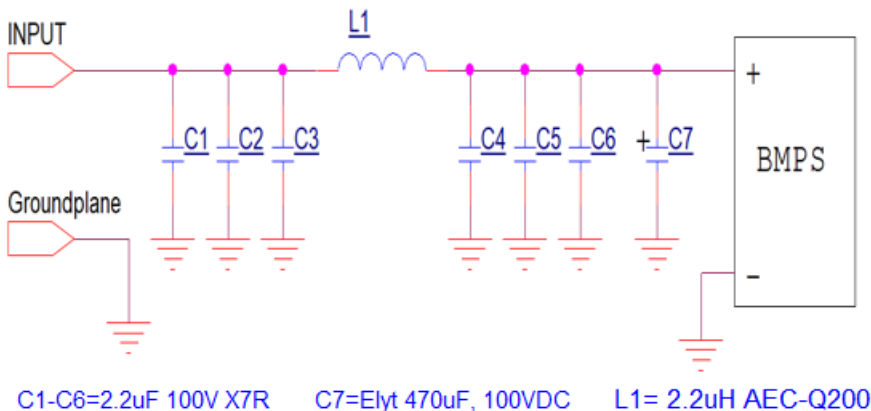

Electrical specifications for BMR320**6.7 V, 60 A \leq 400 W**

Min and Max values are valid for: $T_{P1} = -40$ to $+85^{\circ}\text{C}$, $V_{in} = 40$ to 60 V, unless otherwise specified under conditions. Typical values given at: $T_{P1} = +25^{\circ}\text{C}$, $V_{in} = 54$ V, max P_{out_TDP} , unless otherwise specified under conditions, see Note 1.

Additional external $C_{in} = 220$ μF , $C_{out} = 1$ mF

Characteristic	conditions	minimum	typical	maximum	unit
Key features					
Efficiency (η)	50% of P_{out_TDP}		97.6		%
	100% of P_{out_TDP}		96.5		%
	50% of P_{out_TDP} $V_{in} = 40\text{V}$		96.9		%
	100% of P_{out_TDP} $V_{in} = 40\text{V}$		95.7		%
P_{out_TDP} thermal design power (TDP)	See Note 1			400	W
Recommend capacitive load		110		5000	μF
Power Loss	50% of P_{out_TDP}		5.5		W
	100% of P_{out_TDP}		14		W
	50% of P_{out_TDP} $V_{in} = 40\text{V}$		6.1		W
	100% of P_{out_TDP} $V_{in} = 40\text{V}$		22		W
Input characteristics					
Input voltage range (V_{in})		40	54	60	V
Input OVP		63	64	65	V
Recommended external input capacitance		47		470	μF
Output characteristics					
Output voltage initial setting and accuracy	$P_{out} = 0$ W	5	6.7	7.5	V
Output current (I_{out})	$V_{in} = 40 - 60$ V	0	60	80	A
Max start-up load	Max load			5	A
Load transient voltage deviation	See Note 2		± 200		mV
Load transient recovery time	See Note 2		5		ms
Output ripple & noise	max P_{out_TDP}			50	mV_{p-p}

Note 1: Max. output current is rated at 60 A at 54V in. Max power is $\leq 400\text{W}$ and continuous power (thermal design power (TDP)) is ≤ 400 W depending on thermal conditions.

Note 2: Load step 25-75-25% of max P_{out_TDP} $di/dt = 1$ A/ μs .

Electrical specifications for BMR320**6.7 V, 60 A \leq 400 W**

Characteristic	conditions	minimum	typical	maximum	unit
On/off control					
Turn-off input voltage	Decreasing input voltage		35.5		V
Turn-on input voltage	Increasing input voltage		37		V
Minimum enable activate time from 5V VCC applied		50			ms
Ramp-up time (from 10–90% of V _{out})			8		ms
Enable start-up time				20	ms
Logic high: trigger level	Voltage Rising			0.7	V
Logic low: trigger level	Voltage Falling	0.6			V
Logic high: response time			0.5		ms
Sink current			0.35		mA
Protection features					
Output current limit (OCP) response and type	Slow (Fast) Latching	85	90 (240)	100	A
Output overvoltage protection (OVP)			7.9		V
Output overvoltage protection (OVP) response and type	Latching			100	us
Over temperature protection (OTP)			125		°C
Over temperature protection (OTP) response and type				100	us
5.0 V Vcc Auxiliary power					
Voltage		4.5	5.0	5.5	V
Current	Note 1			200	mA

Note 1: In standby, the current draw is approximately 20 mA.

Electrical specifications for BMR320 1000/001**6.7 V, 60 A (80 A) ≤ 400 W**

In the table below all PMBus are written in capital letters.

$T_{P1} = -40$ to $+125$ °C, $V_{in} = 40$ to 60 V, unless otherwise specified under conditions.

Typical values given at: $T_{P1} = +25$ °C, $V_{in} = 54$ V, max P_{out_TDP} , unless otherwise specified under conditions

Command	Conditions	minimum	typical	maximum	Unit
Monitoring accuracy					
Input voltage READ_VIN			±0.3	±2	V
Output voltage READ_VOUT			±80	±250	mV
Output current READ_IOUT			±1.5	±5	A
Temperature READ_TEMPERATURE_1	See Note 1		±1	±5	°C

Note 1: Depends on cooling type and thermal resistance.

Note 2: Below 0° C the temperature telemetry readings deviation is higher and not possible to read temperature lower then -22°C

For more detailed information please refer to Technical Reference Document: PMBus commands.

This product is supported by the [Flex Power Designer tool](#).

Electrical graphs for BMR320 1000/001

6.7V, 60A (80A) \leq 400W

Efficiency

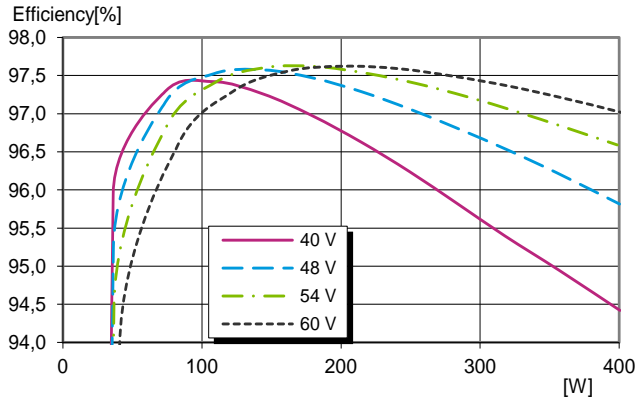

Power dissipation

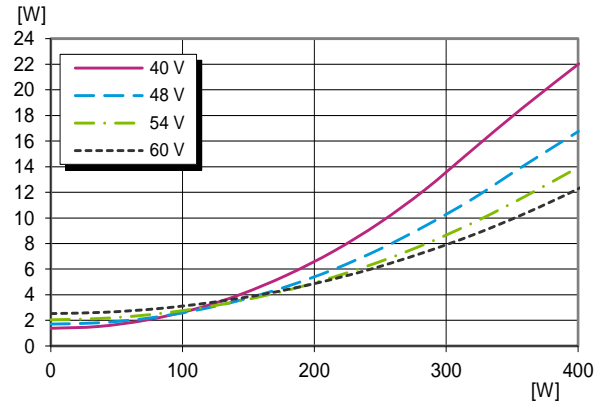

Part 2: EMC

Optional external filter for Class B

Suggested external input filter in order to meet Class B in EN 55022 / EN 55032, CISPR 22 / CISPR 32 and FCC part 15J.

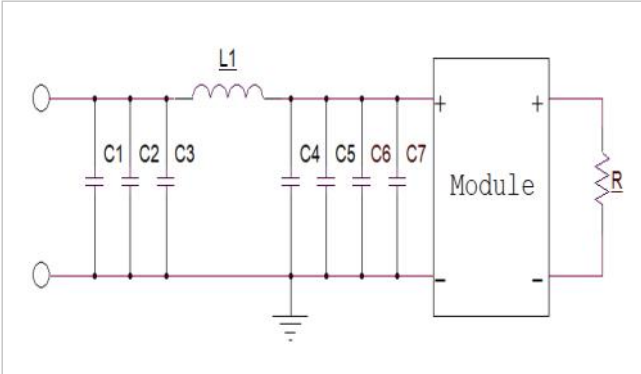

Filter components:

C1-C6 2.2 μ F 10% 1210 100V X7R, capacitor

C7 470 μ F 100VDC 20%, Electrolite capacitor

L1 2.2 μ H 20% 12A DC, Inductor

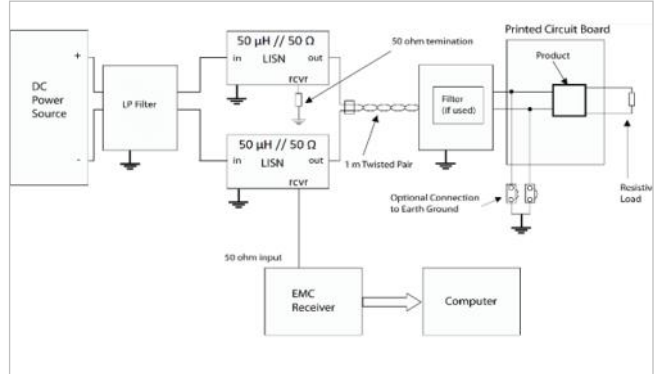

Test set-up

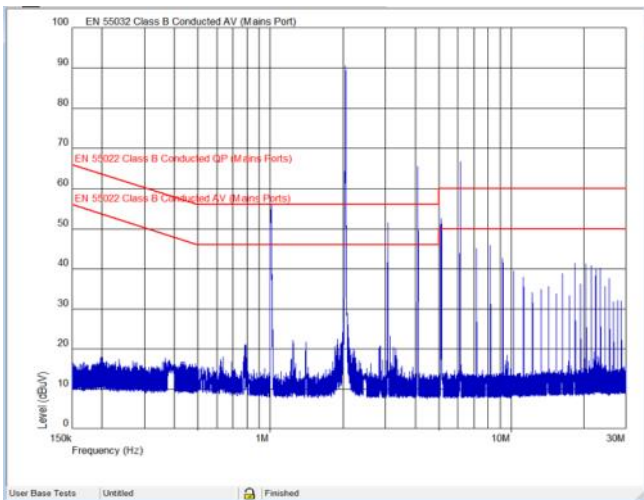

Without EMC filter, $V_{in} = 54$ V, $\max P_{out_IDP}$

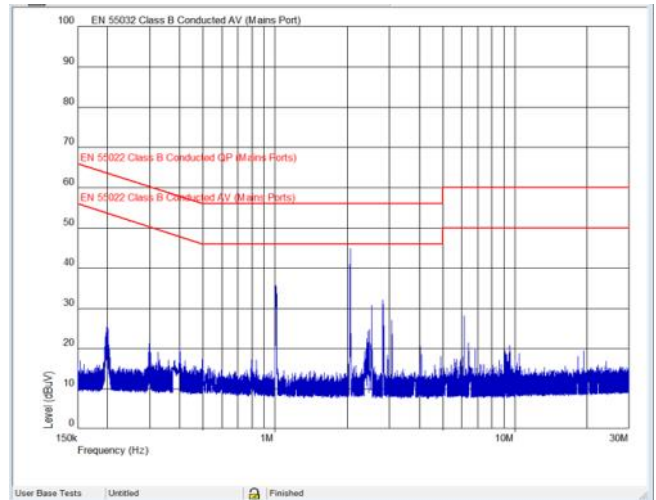

With EMC filter, $V_{in} = 54$ V, $\max P_{out_IDP}$

Part 3: Mechanical information

BMR320 xxxx/xxx: surface mounted

Bottom view

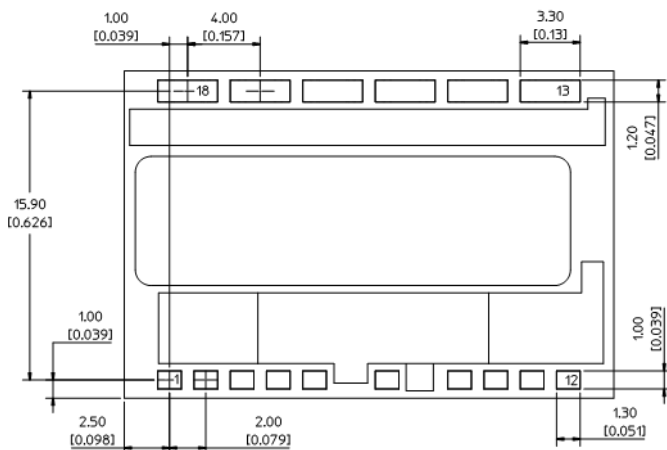

Side view

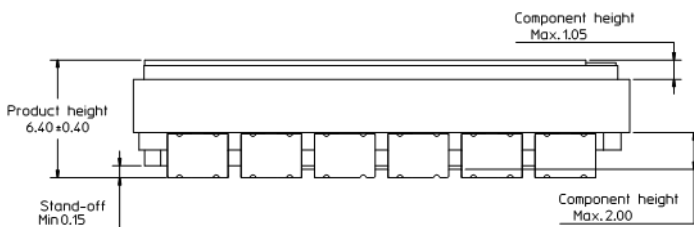

Pins

Material: Copper alloy

Plating: Min 0,1 μm Au over 2 μm Ni

Module weight: typical 9.3 g

All dimensions in mm [inches]

Tolerances unless specified:

x.x ± 0.5 mm [0.02 inch]

x.xx ± 0.25 mm [0.01 inch]

(not applied on footprint or typical values)

Note: Max pull force 6N, this applies for an orthogonal force widespread over the whole ferrite surface

Top View - Recommended footprint all variants showing pin positions

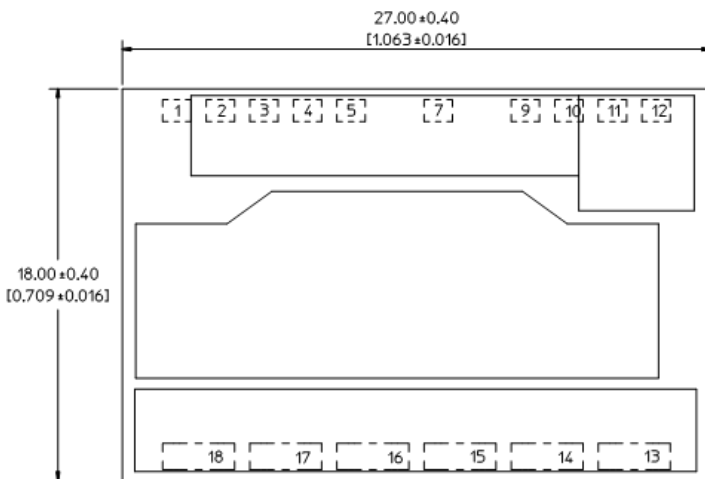
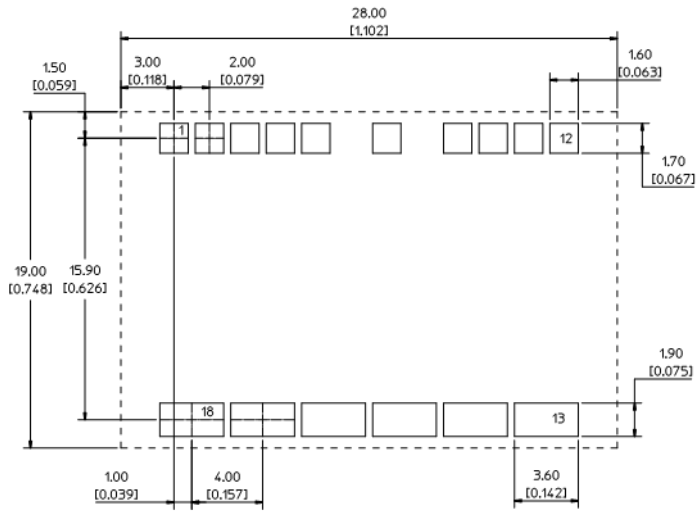

Pin	Designation
1	Not connected
2	SCL
3	SDA
4	GND
5	ADDR
6	Not mounted
7	VIN
8	Not mounted
9	5V Vcc

Pin	Designation
10	Not connected
11	ON/OFF
12	PGOOD
13	Vout+
14	GND
15	Vout+
16	GND
17	Vout+
18	GND

Part 4: Thermal considerations

The products are designed to operate using a heatsink mounted on top of the device.

General

For products mounted on a PWB with a heatsink attached, cooling is achieved both by conduction, from the pins to the host board, and through the heatsink mounted on top of the device. The wind speed and temperature are measured in a point upstream the device. The output current derating graphs found later in this section provide the available output current vs. ambient air temperature and air velocity at $V_{in} = 54$ V.

For products using any form of heatsink structure a top spacing board and side airflow guides are used to ensure airflow hitting the module and not diverted away.

Distance between the tested device and the top space board and the side airflow guides are $6.35 \text{ mm} \pm 1 \text{ mm}$.

The product is tested on a $200 \times 200 \text{ mm}$, $105 \mu\text{m}$ (3 oz), 6-layer test board mounted vertically in a wind tunnel.

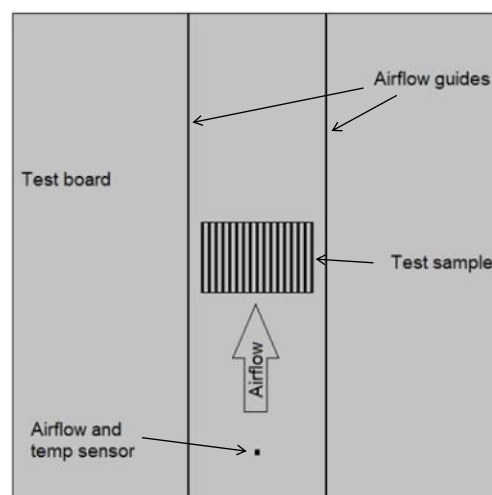
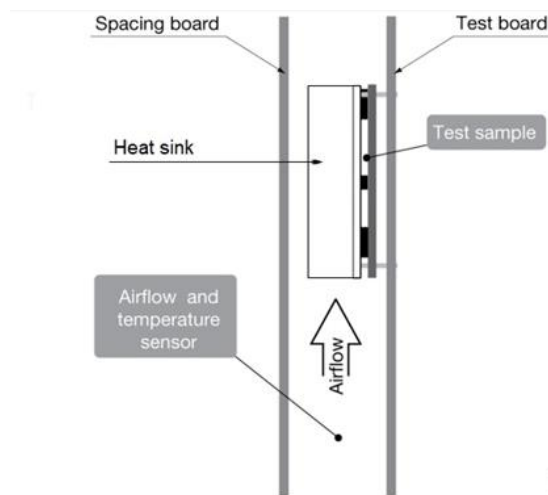

Part 4: Thermal considerations

Definition of product operating temperature

Proper thermal conditions can be verified by measuring the temperature at position P1 as shown below. The temperature at this position (T_{P1}) should not exceed the maximum temperatures in the table below. The number of measurement points may vary with different thermal design and topology. Temperatures above maximum T_{P1} , measured at the reference point P1 are not allowed and may cause permanent damage.

Position	Description	Max. Temp.
P1	PWB TOP side	$T_{P1} = 125\text{ }^{\circ}\text{C}$

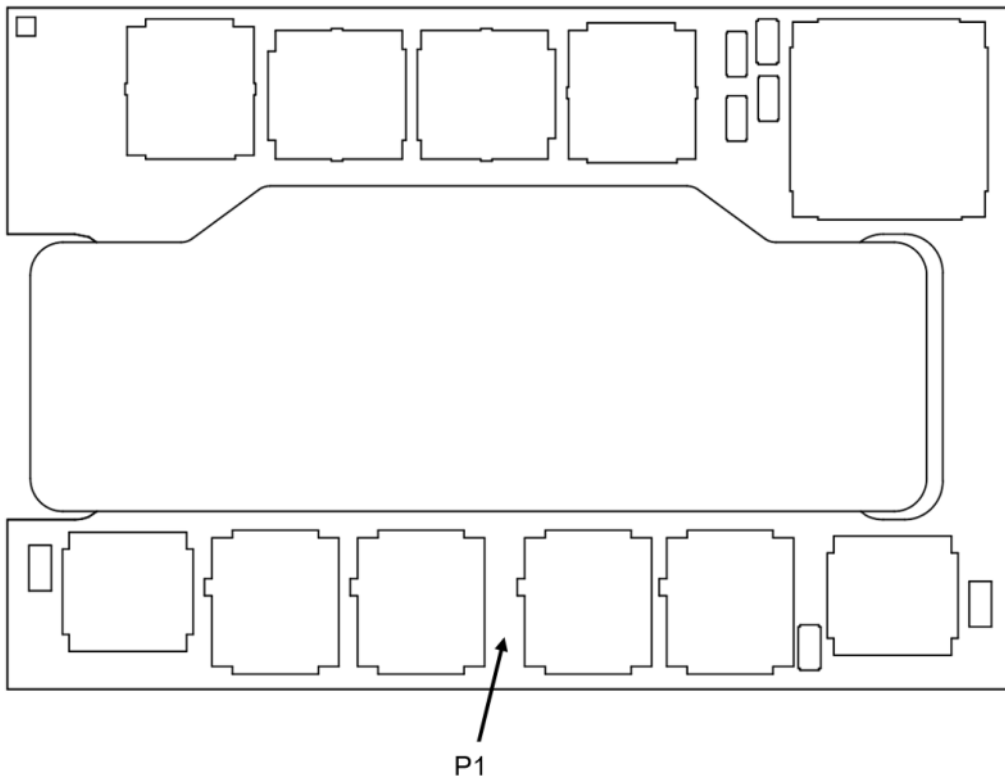
TOP view

Part 4: Thermal considerations

Thermal graphs

Output power derating

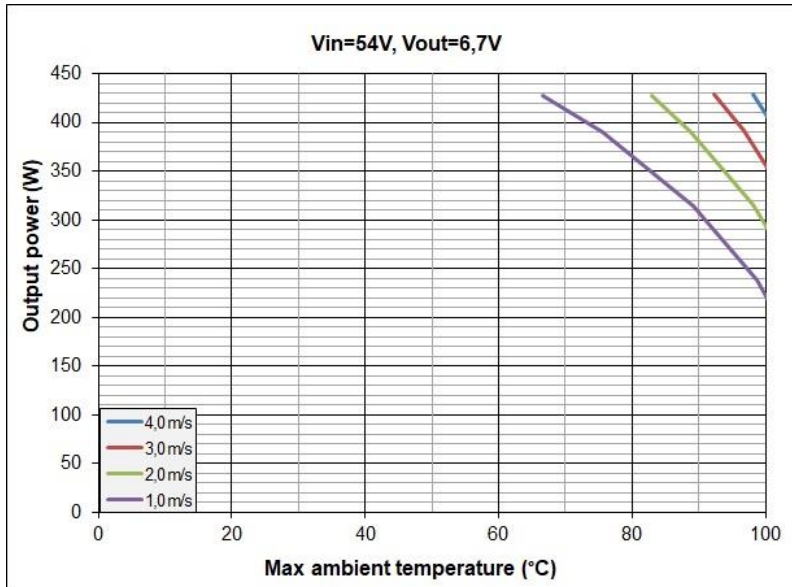

Device with 4.7 K/W thermal resistance heat sink.

Part 5: Packaging

Packaging information

The surface mount products are delivered in an antistatic carrier tape (Jedec design EIA 481 standard).

Carrier Tape Specification	
Material	Antistatic PS
Surface resistance	$10^7 < \text{ohm/square}$
Bakability	Tape cannot be baked
Tape width, W	56 mm [2.2 inch]
Pocket pitch, P_1	28 mm [1.1 inch]
Pocket depth, K_0	7.75 mm [0.287 inch]
Reel diameter	380 mm [15 inch]
Reel capacity	200 products /reel
Reel weight	2.3 kg/full reel

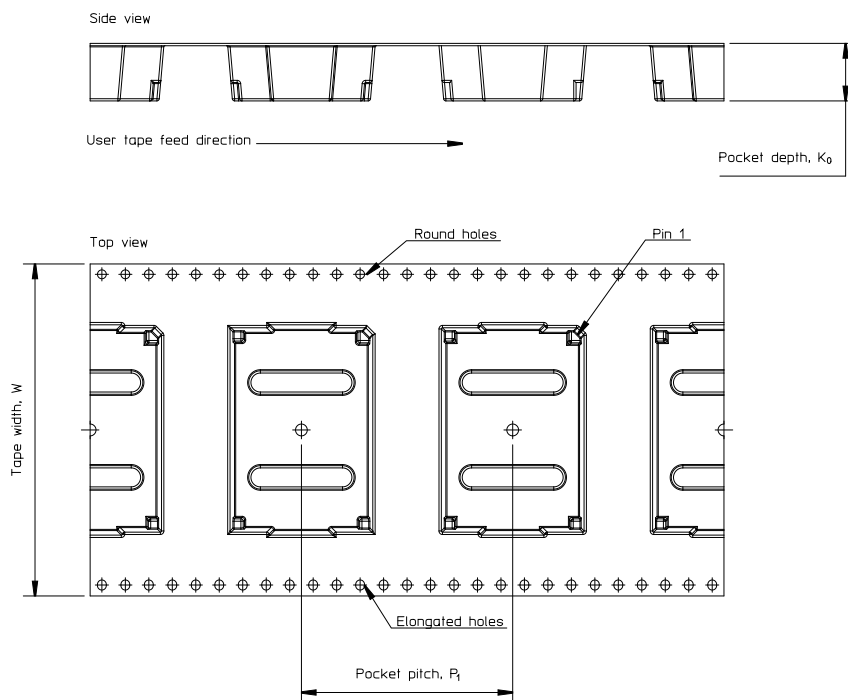

Part 6: Revision history

Revision table

Revision number	revision change	date	revisor
Rev. A	New document	2023-04-19	karasell
Rev. B	Updated footer	2023-04-19	kartwaer
Rev. C	Added note info on page 9	2023-05-08	kartwaer

© Flex Power Modules 2023

The information and specifications in this technical specification is believed to be correct at the time of publication. However, no liability is accepted for inaccuracies, printing errors or for any consequences thereof. Flex reserves the right to change the contents of this technical specification at any time without prior notice.



Flex Power Modules, a business line of Flex, is a leading manufacturer and solution provider of scalable DC/DC converter primarily serving the data processing, communications, industrial and transportation markets. Offering a wide range of both isolated and non-isolated solutions, its digitally-enabled DC/DC converters include PMBus compatibility supported by the powerful [Flex Power Designer](#).

