



Safety Requirements for Board-Mounted DC/DC Converters

For many years, the power industry has struggled to understand the safety and isolation voltage requirements that apply to board-mounted DC/DC converter modules due to a complex range of issues. This paper examines the facts and clarifies the safety-related requirements that such modules must meet.

CONTENTS

Introduction	2
Safety standards and their scope	3
Insulation protects people and property	4
Safety extra-low voltage (SELV) circuits	5
Input power sources	6
DC/DC converter isolation requirements	7
Market requirements and system-level considerations	8
Conclusions	10

For many years, the power industry has struggled to understand the safety and isolation voltage requirements that apply to board-mounted DC/DC converter modules for use within information and communications technology (ICT) equipment. System designers frequently interpret safety standards differently, most often because the core specifications were originally intended for AC-line powered equipment rather than DC-powered components on a PWB. It has even been known for product marketers to manipulate perceptions in order to drive a traditionally conservative customer base into demanding specifications that the safety agencies do not require.

Ultimately of course, the safety standards demand that equipment and any other applicable entities meet a definite set of requirements. In some circumstances, market pressures from suppliers and end-users may influence accepted practice and impose further restrictions. Here, we examine the facts and clarify what is really necessary in terms of the safety and isolation requirements that on-board DC/DC converter modules must meet.

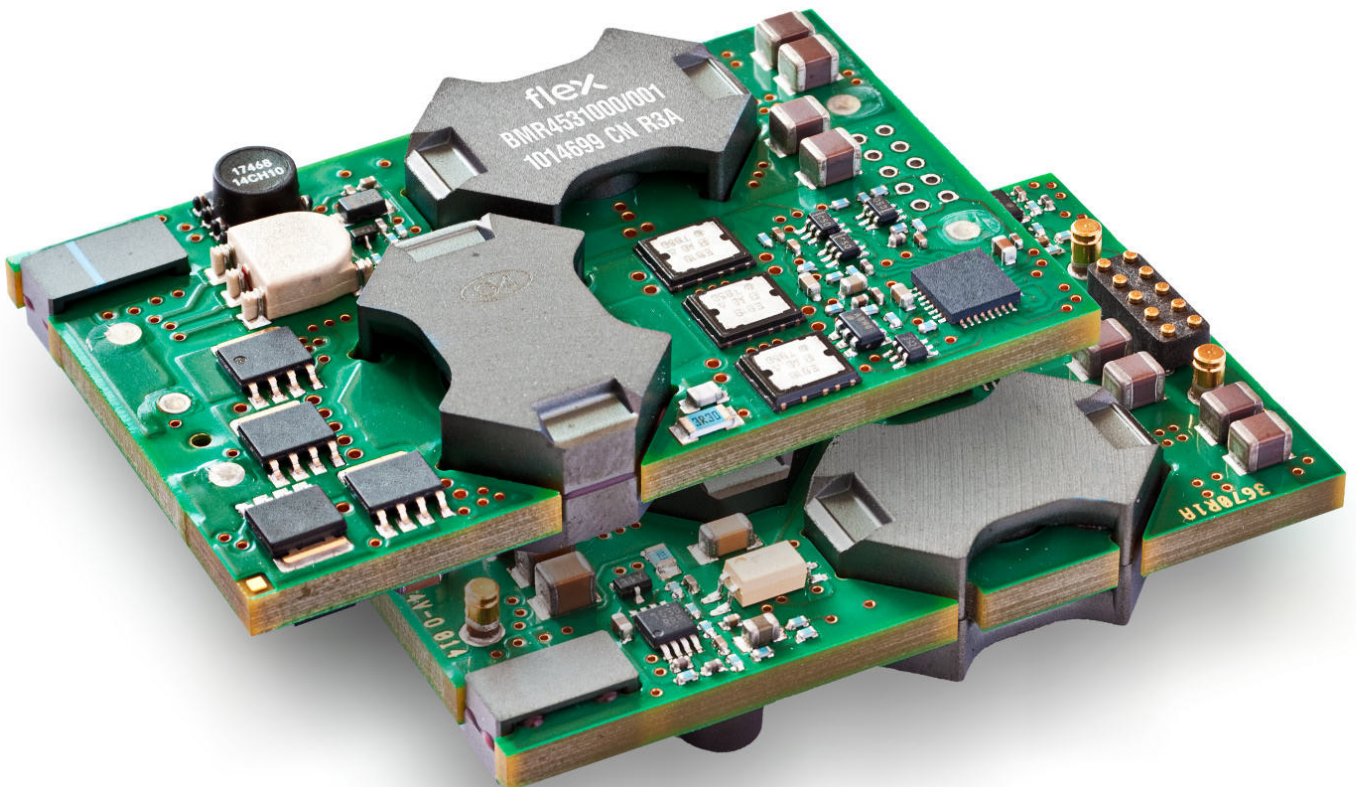

BMR 453
Quarter-brick – 396 W output power
36 V to 75 V input voltage – 8 V to 13 V output voltage – 1500 VDC isolation

Safety Standards and Their Scope

The core safety standard that applies to ICT equipment that operates from AC-line or battery supplies of up to 600 V is IEC 60950-1, "Information technology equipment - Safety". Now in its second edition, this standard underpins regional adoptions such as Europe's EN 60950-1 and UL/CSA 60950-1 that apply in the US and Canada, and AS/NZS 60950-1 that serve Australia and New Zealand. Application- and product-related standards such as ETS 300 132-2 "Power supply interface at the input to telecommunications equipment" and IEEE 802.3af "DTE Power via MDI" for Power-over-Ethernet (PoE) may also apply for some equipment, but these standards reference IEC 60950-1 for any relevant safety-related aspects.

For the national standards bodies and regulatory authorities, a key objective in the drive towards global harmonization is to ensure that any adoption of a core standard is interchangeable with any other — and this effort continues for 60950-1. In the text that follows and unless stated otherwise, "the standard" refers to IEC 60950-1 Second Edition that was published in 2005. Following a transitional period to permit industry to adapt to a new set of conditions with several significant changes, the previous edition was withdrawn in December 2010 and the second edition now applies.

In addition to ICT equipment, the second edition encompasses telecommunications infrastructure equipment regardless of its power source. It also applies to components and sub-assemblies that have intrinsic safety implications — such as power supplies — that equipment makers incorporate within their end products. The standard recognizes that individual parts may not be able to meet every aspect of its requirements, but demands that the end product that houses them is fully compliant. As "component power supplies", on-board DC/DC converter modules cannot entirely meet the standard's demands. It then becomes the equipment maker's responsibility to ensure that the end product fulfils all regulatory obligations.

End products are far more likely to easily and quickly obtain safety approval if an accredited agency has examined and qualified any component that has safety implications. As a result, suitably-qualified DC/DC converter modules greatly benefit equipment makers, with component manufacturers typically offering approval regimes that satisfy regional demands. For instance, UL (Underwriters Laboratories, Inc.) provides certification to

suit the US, Canada, and Europe singly or in any combination. An update to the familiar UL mark identifies the regions for which certification applies with the letters US, C, and/or EU appearing around the logo's periphery.

The Recognized Component Mark scheme that UL operates assures that any qualified component is safe to use within end products providing that installation takes place within a controlled environment — that is, a factory rather than a field site. A "Conditions of Acceptability" statement documents how to install and use the component within end products, and providing that the equipment maker adheres to these requirements, the component requires no further safety inspection.

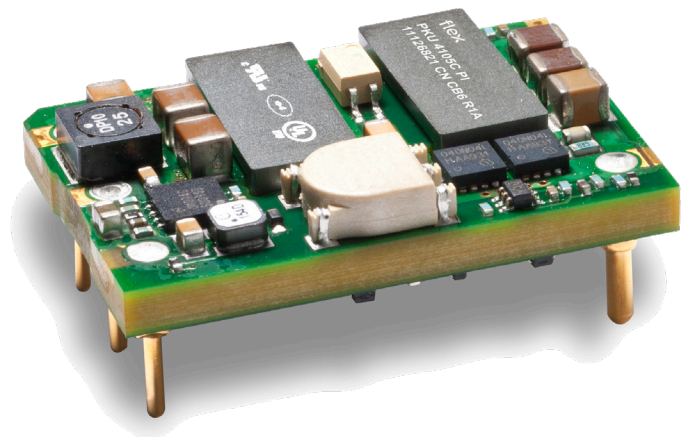

PKU4105C PI
1/16th brick – UL mark identifies the regions for which certification applies with the letters US, C, and/or EU appearing around the logo's periphery

Administered by the global test-house conglomerate Intertek, the ETL mark signifies compliance with applicable international standards via another accredited test organization. Often, the S mark appears alongside the ETL mark to indicate that the component or product meets every safety requirement that European standards demand. Components that display these symbols will already meet major sections of the test suite that equipment makers must perform to gain the CE mark that appears on any electrical equipment for sale within the European Union. To the equipment maker's benefit, the component's manufacturer will have the documentary evidence that CE marking requires as part of the end product's build file.

Insulation Protects People and Property

IEC 60950-1 and its regional adoptions aim to prevent injury or damage to people and property due to these potential dangers:

- > Electric shock
- > Energy hazards
- > Fire
- > Mechanical and heat hazards
- > Radiation hazards
- > Chemical hazards

The standard's guiding principle is to provide two levels of protection from electric shock and energy hazards that may trigger other dangers, such as fire. This two-level model creates a hierarchy of protection measures that builds upon five categories of insulation:

- > Functional insulation
- > Basic insulation
- > Supplementary insulation
- > Double insulation
- > Reinforced insulation

Functional insulation

Providing no reliable protection from electric shock, functional insulation is only necessary for the product to function. It may reduce the likelihood of ignition and fire hazards, but it must satisfy at least one of these sets of the standard's requirements:

- a) Clearance and creepage distances
- b) Electrical strength tests
- c) Fault condition testing

Basic insulation

The standard defines this category as "insulation to provide basic protection against electric shock". It must satisfy parts a), b), and c) in the previous section, which also apply in varying degrees of stringency to subsequent categories of insulation.

A key part of the standard's requirements concerns clearance and creepage distances. Clearance is the shortest distance between two conductive parts, or between a conductive part and the bounding surface of a component (such as a connector) or equipment as measured through air. Creepage is the same dimension in each case, but is measured across the surface of the insulation.

Different minimum clearance and creepage distances apply for primary and secondary circuits. A primary circuit connects directly to the AC line supply, while a secondary circuit has no direct connection to a primary circuit. Secondary circuits derive power from an isolating device such as a transformer or an isolated DC/DC converter, or from batteries.

Minimum clearance and creepage distances also take into account factors such as altitude; the material group of the insulator; transient voltages in AC line circuits; peak working voltage; and pollution degree in three bands that range from clean and dry surfaces to humid, chemically-contaminated ones. Tables that plot various conditions identify the requirements for a particular application, and some results may surprise you — such as the huge reduction in creepage distances that results from coating a bare PWB with solder resist.

Electrical strength tests ensure that insulation does not break down under stress. Test voltages are a product of primary or secondary circuit use and/or peak working voltages, resulting in a withstand voltage. The insulation category may apply a multiplier to this value.

The standard does not prescribe any specific fault condition testing for basic insulation or any of the categories that follow. It includes a mass of informative guidance and example test scenarios for e.g. transformers, semiconductors, and capacitors that a test house may apply to ensure that the application is free from all identifiable hazards, which may involve inspecting circuit diagrams, components, and/or end equipment.

Supplementary insulation

Supplementary insulation adds another layer of protection to basic insulation that guards against failures in the basic insulation barrier. Logically, the same requirements that apply to basic insulation should apply, but other stipulations may exist such as the requirement for 0.4 mm greater distance through insulation for peak working voltages above 71 V.

Double insulation

Double insulation results from combining basic insulation and supplementary insulation.

Reinforced insulation

This is a single insulation system that provides the same level of protection from electric shock as double insulation. This does not necessarily mean that the reinforced insulation barrier is physically

one homogenous piece — it could comprise several layers that are not possible to categorize and test as basic and supplementary insulation.

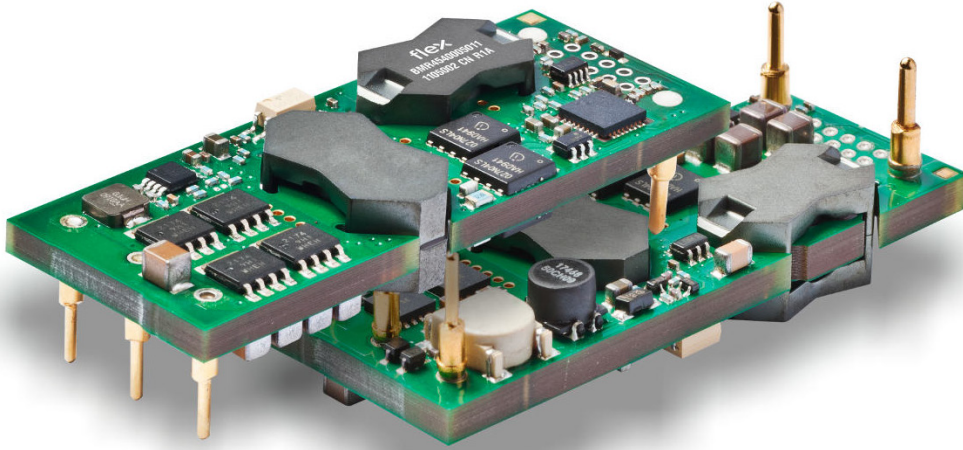

BMR454
Digitally-controlled and fully-regulated eighth-brick intermediate bus converter provides 1500 VDC isolation for distributed power architectures.

Isolation Voltage

Isolation voltage is the voltage that a product must withstand in the standard's electrical strength test. For a DC/DC converter module, this withstand voltage depends upon the part's working voltage, which for an isolated converter will be the highest continuous voltage that exists between the input and output sides of the circuit. Accordingly, the isolation voltage value depends on the converter's input voltage, topology, and design, and typically ranges from 1000 to 1400 VDC.

Commercially-available isolated DC/DC converter modules almost invariably specify 1500 VDC isolation, which has become industry-accepted practice. Some converters may specify higher withstand voltages for a short time. In addition, application-specific standards such as IEEE 802.3af may require 2250 VDC isolation for Power-over-Ethernet (PoE) devices that distribute network power via Ethernet data cables in outdoor environments, such as between buildings.

Safety Extra-Low Voltage (SELV) Circuits

Safety extra-low voltage (SELV) circuits generally feature safety isolation from primary circuits and AC line voltages using reinforced or double insulation, and have a low voltage output level that is not harmful to the human body. This level may not exceed 42.4 V peak or 60 VDC between conductors or from a conductor to

safety Earth, and will be safe to touch under normal operating conditions. If a SELV circuit connects to protective Earth, basic insulation is adequate for the barrier to a primary circuit. A single fault shall not compromise safety. The output of a board-mounted DC/DC converter module is normally a SELV circuit.

Input Power Sources

The standard describes many scenarios for interconnecting different classes of circuits and appropriate measures to assure safety, such as the need for isolation barriers and protective Earthing. For instance, ICT equipment such as PCs and office machines invariably include an AC/DC front-end power supply that isolates the voltages that supply load circuits from the AC-line supplied primary circuit, creating a secondary circuit. Most often, one pole of the secondary circuit connects to protective Earth, as will any external or accessible conductive surfaces. There is then no opportunity for dangerous fault currents to flow through an operator's body to Earth.

Telecoms infrastructure equipment traditionally operated from a 48 VDC battery supply with the positive rail connecting to protective Earth. Today, an AC/DC front-end supplies normal operating power, with the battery system taking over if the AC line supply fails. This reliable model also applies for a great deal

of datacomms equipment and a growing number of industrial applications. The telecoms industry standard that applies to 48 VDC power systems is ETSI EN 300 132-2, where the service voltage range is 40.5 – 57.0 VDC and the maximum abnormal voltage is 60 VDC.

Some legacy telecoms battery-powered DC supply systems used a nominal 60 VDC level that is rare today. In this and similar cases, IEC/UL/EN 60950-1 may apply the TNV 2 (telephone network voltage) circuit classification. This is a secondary circuit whose normal operating voltages exceed the 60 VDC limit for SELV, but that is not exposed to overvoltages from external telecoms networks. If the secondary circuit does not meet the requirements for SELV or TNV-2, the hazardous voltage classification applies. The operational range for onboard DC/DC converters that downconvert distribution-level voltages is typically 36 – 72 VDC, and the absolute maximum input voltage is 75 VDC.

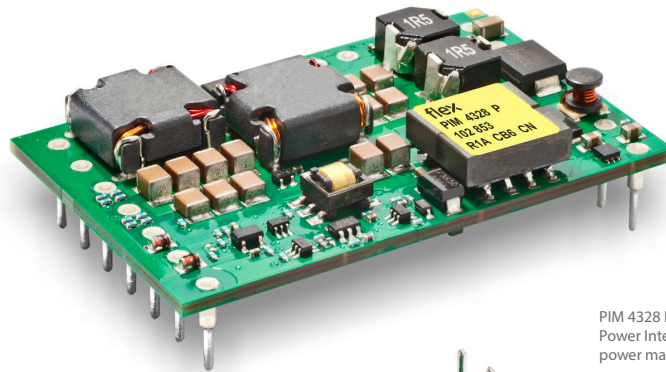

PIM 4328 P
Power Interface Modules with built-in power converter for power management and alarm, 2250 VDC isolation compliant.

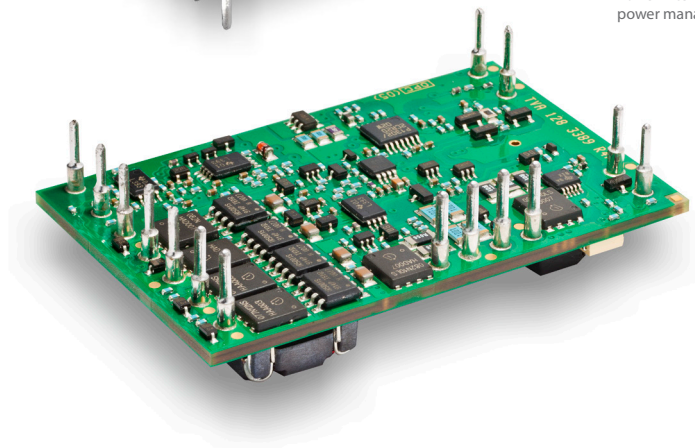

DC/DC Converter Isolation Requirements

For ICT equipment, designers normally expect that the output side of an isolated DC/DC converter meets the criteria for a SELV circuit that limits voltages to a safe level under both normal operation and single fault conditions. The isolation requirements that the DC/DC converter must then satisfy depend on the isolation that the AC/DC front-end power supply provides, together with the converter's normal input voltage level and the system's arrangements for connection to protective Earth.

Functional insulation between the DC/DC converter's input and output is allowed if:

- > The AC/DC power supply has reinforced or double insulation between the AC line supply and its DC output. (The DC/DC converter must pass fault condition testing and withstand an electrical strength test for basic insulation if its normal input voltage exceeds 60 VDC.)
- > The AC/DC power supply has basic or supplementary insulation between the AC line supply and its DC output, and the output of the DC/DC converter connects to protective Earth. (Again, the DC/DC converter must pass fault condition testing and withstand an electrical strength test for basic insulation if its normal input voltage exceeds 60 VDC.)
- > The AC/DC power supply has basic or supplementary insulation between the AC line supply and its DC output, and the input of the DC/DC converter connects to protective Earth. (In this case, the normal input voltage must not exceed 60 VDC.)

Basic insulation is required if:

- > The AC/DC power supply has functional insulation between the AC line supply and its DC output and the output of the DC/DC converter connects to protective Earth.

Supplementary insulation is required if:

- > The AC/DC power supply has basic insulation between the AC line supply and its DC output. (The AC/DC power supply's output voltage must not exceed 60 VDC.)

Reinforced or double insulation is required if:

- > The AC/DC power supply has no insulation or functional insulation between the AC line supply and its DC output.

In summary, this means that functional insulation is adequate for the DC/DC converter in almost all practical system implementations. If the converter's normal input voltage exceeds 60 VDC, it must additionally withstand an electrical strength test for basic insulation and pass fault condition testing.

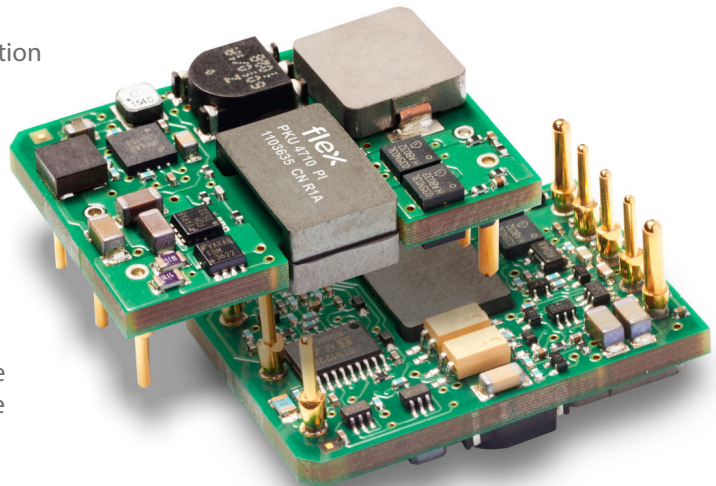

PKU 4710 PI/SI
Compact sixteenth brick footprint to address highly integrated applications requiring 1500 VDC isolation.

Market Requirements and System-Level Considerations

Clearly, safety is a crucially important factor, which tempts some on-board DC/DC converter manufacturers to exploit safety requirements in their marketing material — for instance, claiming “designed to meet basic insulation” or “equivalent to basic insulation”. Most often, analysis reveals that these and similar statements mean that the isolation barrier passes an electrical strength test for basic insulation, which is only one of the standard’s requirements for basic insulation. If you are not familiar with the terms that the safety standards use, it is easy to confuse the marketer’s language with the standard’s definitions.

Another soft target is claiming that 2250 VDC is necessary to meet isolation voltage requirements. In fact, only the IEEE 802.3af Power-over-Ethernet standard requires this level, and only then for specific central-office devices that supply power to lines that traverse outside environments, such as links between buildings. Again, it is easy to confuse unqualified marketing claims with the 1000 to 1400 VDC isolation voltage that IEC 60950-1 requires for standard on-board DC/DC converters.

The on-board DC/DC converters that power ICT equipment in telecoms and similar applications are typically part of a “two-wire” or “three-wire” system (Figures 1 and 2). AC/DC power supplies with reinforced or double insulation, or as a minimum basic and

supplementary insulation, supply distribution-level DC power. As we have noted, the DC/DC converter’s output side typically qualifies as a SELV circuit, and in either a two- or three-wire system connects to protective Earth.

In the two-wire system (Figure 1), the input and output grounds connect on the board and then back to the system’s main protective Earth point, while the three-wire system (Figure 2) separates the board’s input and output grounds and independently returns them to protective Earth — either scheme short-circuiting the galvanic isolation between the DC/DC converter’s input and output sides. The choice between a two-wire or three-wire system reflects the system designer’s view of EMC issues. Some engineers believe that the two-wire system with strong mesh bonding networks connecting cabinets and racks is superior, while others believe that the three-wire system that allows separate grounding and a common Earth point is the better choice.

The real objective is to secure a stable signal ground for the equipment while protecting the system from high-energy transients that lightning, short-circuits, or other abnormal conditions may cause. For telecoms systems, there is always a risk that disturbances in the external network may feed through to infrastructure equipment, which will impress transient currents upon the bonding network that connects circuitry and

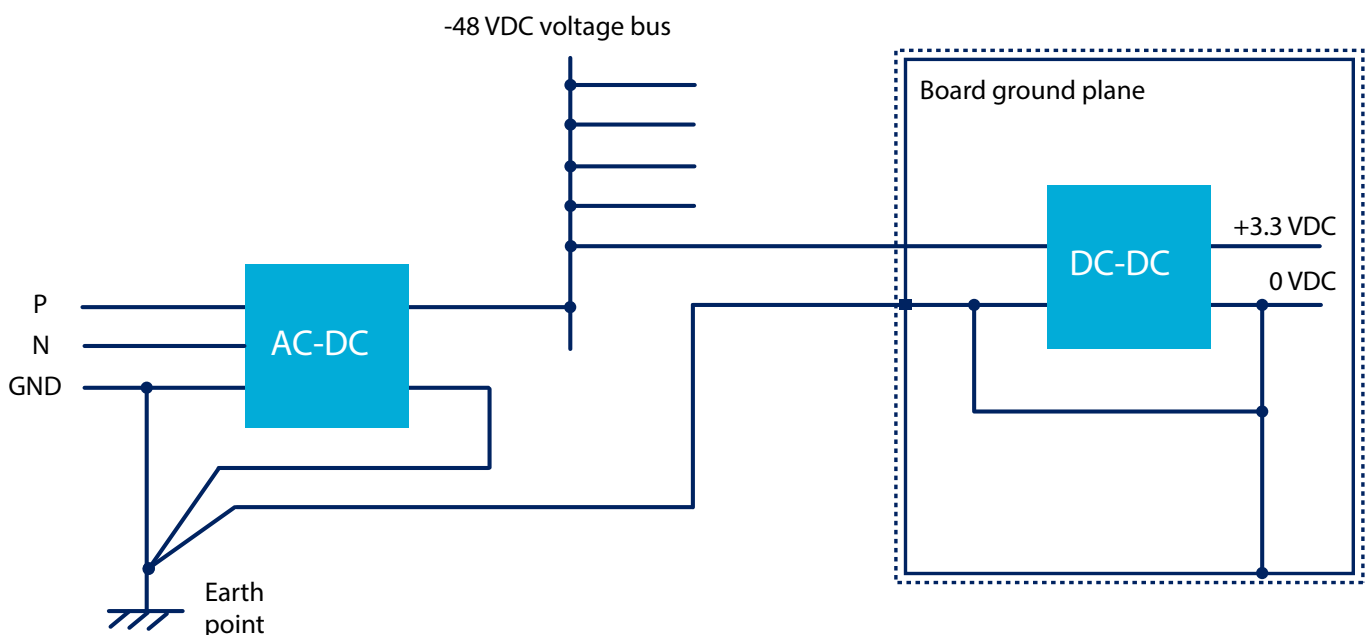

Figure 1: Telecom power system, -48 V/2-wire.

equipment to protective Earth. Other AC-line or DC-distribution bus disturbances can also cause high voltage transients in the bonding network. It is clearly essential that the bonding network and protective Earthing arrangements accommodate potential fault conditions, and the standard pays great attention to this aspect of equipment design.

For a two-wire system, any transient that appears across the DC/DC converter's input and output is effectively eliminated by the low Ohmic connection between both sides. In three-wire systems, the input and output sides also connect, but the impedance between them can be significant due to the resistance and inductance that the cabling presents. This can result in transient voltages between the converter's input and output sides being quite high. In fact, input-side transients such as lightning strikes cause can generate hundreds of volts and even as much as 1500 V peak.

As a result, two-wire systems do not require the DC/DC converter to provide any isolation. However, relatively few ICT equipment makers use the two-wire system, and on-board DC/DC converter manufacturers cannot base their standard product offerings on non-isolated designs. The need to accommodate peak voltages in three-wire systems and allow for a separate signal ground makes functional insulation and a 1500 VDC

isolation voltage mandatory for standard on-board DC/DC converters.

Energy efficiency and power density are always important considerations in any power system. In this respect, isolation will always negatively impact DC/DC converter efficiency, although contemporary designs and techniques such as digital inner-loop control minimize this factor. Less obviously perhaps, basic insulation impacts energy efficiency significantly more severely than functional insulation due to its greater clearance and creepage distance requirements. Increases in the distance between elements in components such as transformers reduce energy coupling efficiency — which also degrades power density — and ultimately result in greater cost-of-ownership. Unless there is a proven need for basic insulation, functional insulation is the better choice.

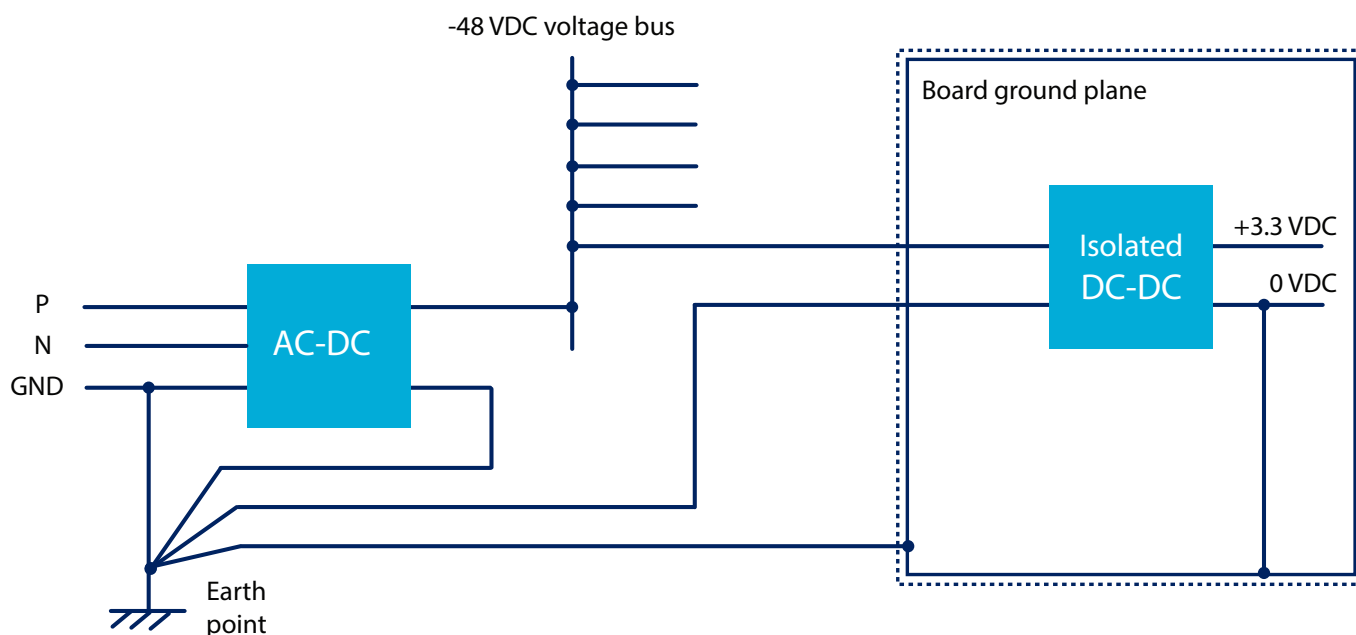

Figure 2: Telecom power system, -48 V/3-wire.

Conclusions

An isolation barrier between the input and output sides of on-board DC/DC converters for use in ICT equipment is typically unnecessary for product safety. The real reason for the isolation barrier is to protect the DC/DC converter from transients across the input and output in three-wire systems, and functional insulation is adequate.

General market requirements dictate that if the DC/DC converter's input voltage might exceed 60 VDC, it must pass a 1500 VDC electrical strength test for basic insulation. The 2250 VDC isolation voltage level is only necessary for certain PoE power devices, but de-facto standards or regional market demands may also require it.

The most efficient approach to satisfying safety issues in the end product or equipment is to use reinforced or double insulation (or alternatively basic and supplementary insulation) in the front-end AC/DC power supply. Other issues such as how to install and use the DC/DC converter and implement protective Earthing arrangements are application-dependent. Given sufficient forethought, it is not difficult to meet IEC/UL/EN 60950-1's requirements alongside the normal considerations for optimizing the system's energy efficiency and reliability while lowering its total cost-of-ownership.

Trademarks

Flex and the Flex logotype is the trademark or registered trademark of Flex Inc.

All other product or service names mentioned in this document are trademarks of their respective companies.

31/28701-FGB 101378 Uen Rev B
© Flex Dec 2017. All rights reserved.