

BMR492 series DC-DC Converters Input
40 - 60 V, Output up to 42 A / 504 W

28701-BMR49203 03 revB May 2021

© Flex

Key Features

- Industry standard low profile Eighth Brick
58.4 x 22.7 x 13.0 mm – with baseplate
(2.299 x 0.894 x 0.512 in)
- High efficiency, typ. 96.8% at 48Vin, 12Vout, half load
- Input to output 2250V isolation
- Innovative thermal management for enhanced performance
- MTBF up to 6.6 Million hours
- Highly automated manufacturing ensures quality ISO 9001/14001 certified supplier



General Characteristics

- Input voltage range: 40V-60V
- Max output power: 504W
- Monotonic start-up
- Output over voltage protection
- Over temperature protection
- Output short-circuit protection
- Remote control
- PMBus Configuration



Safety Approvals



Design for Environment



Meets requirements in high-temperature lead-free soldering processes.

Contents

Ordering Information	2
General Information	2
Safety Specification	3
Absolute Maximum Ratings	4
Electrical Specification	
12 V, 42 A / 504 W	BMR4920303/862..... 8
EMC Specifications	12
Power Management Overview	13
Operating Information	14
Thermal Consideration	18
Connections	19
Mechanical Information	20
Soldering Information	21
Delivery Information	22
Product Qualification Specification	24
PMBus Commands	25

BMR492 series DC-DC Converters Input 40 - 60 V, Output up to 42 A / 504 W

28701-BMR49203 03 revB May 2021

© Flex

Ordering Information

Product program	Vin	Output
BMR4920303/862	40 – 60 V	12 V / 42 A , 504 W

Product number and Packaging

BMR492 n ₁ n ₂ n ₃ n ₄ / n ₅ n ₆ n ₇ n ₈									
Options	n ₁	n ₂	n ₃	n ₄	/	n ₅	n ₆	n ₇	n ₈
Mechanical option	o				/				
Baseplate		o			/				
Hardware option			o	o	/				
Configuration file					/	o	o	o	
Delivery package									o

Options	Description
n ₁	0 = Standard pin length 5.33mm (0.210 in) 2 = Lead length 3.69mm (0.145 in) (cut) 3 = Lead length 4.57mm (0.180 in) (cut)
n ₂	3 = Baseplate
n ₃ n ₄	03 = 40-60 Vin, 12 Vout, 500W, 2250V isolation, with 7-pin digital interface
n ₅ n ₆ n ₇	862 = CDA Configuration for 40-60 Vin, 12V, 504W, isolated xxx = Available for application specific configuration
n ₈	Blank = foam tray (default option) for wave soldering H = hard tray in dry pack for pin in paste

Example: a BMR492 12V/500W product with standard pin length, baseplate, 7-pin digital interface and standard CDA configuration, in hard tray package will be BMR4920303/862H.

* Standard variant (i.e. no option selected).

General Information

Reliability

The failure rate (λ) and mean time between failures (MTBF = $1/\lambda$) is calculated at max output power and an operating ambient temperature (T_A) of +40°C. Flex Power uses Telcordia SR-332 Issue 4 Method 1 to calculate the mean steady-state failure rate and standard deviation (σ).

Telcordia SR-332 Issue 3 also provides techniques to estimate the upper confidence levels of failure rates based on the mean and standard deviation.

Mean steady-	Std. deviation, σ
151nFailures/h	22.5 nFailures/h

MTBF (mean value) for the BMR492 series = 6.64 Mh.

MTBF at 90% confidence level = 5.58 Mh

Compatibility with RoHS requirements

The products are compatible with the relevant clauses and requirements of the RoHS directive 2011/65/EU and 2015/863 and have a maximum concentration value of 0.1% by weight in homogeneous materials for lead, mercury, hexavalent chromium, PBB, PBDE, DEHP, BBP, DBP, DIBP and of 0.01% by weight in homogeneous materials for cadmium.

Exemptions in the RoHS directive utilized in Flex Power products are found in the Statement of Compliance document.

Flex Power fulfills and will continuously fulfill all its obligations under regulation (EC) No 1907/2006 concerning the registration, evaluation, authorization and restriction of chemicals (REACH) as they enter into force and is through product materials declarations preparing for the obligations to communicate information on substances in the products.

Quality Statement

The products are designed and manufactured in an industrial environment where quality systems and methods like ISO 9000, Six Sigma, and SPC are intensively in use to boost the continuous improvements strategy. Infant mortality or early failures in the products are screened out and they are subjected to an ATE-based final test. Conservative design rules, design reviews and product qualifications, plus the high competence of an engaged work force, contribute to the high quality of the products.

Warranty

Warranty period and conditions are defined in Flex Power General Terms and Conditions of Sale.

Limitation of Liability

Flex Power does not make any other warranties, expressed or implied including any warranty of merchantability or fitness for a particular purpose (including, but not limited to, use in life support applications, where malfunctions of product can cause injury to a person's health or life).

© Flex Power 2021

The information and specifications in this technical specification is believed to be correct at the time of publication. However, no liability is accepted for inaccuracies, printing errors or for any consequences thereof. Flex Power reserves the right to change the contents of this technical specification at any time without prior notice.

BMR492 series DC-DC Converters Input 40 - 60 V, Output up to 42 A / 504 W	28701-BMR49203 03 revB May 2021
	© Flex

Safety Specification

General information

Flex Power DC/DC converters and DC/DC regulators are designed in accordance with the safety standards IEC 62368-1, EN 62368-1 and UL 62368-1 *Audio/video, information and communication technology equipment - Part 1: Safety requirements*

IEC/EN/UL 62368-1 contains requirements to prevent injury or damage due to the following hazards:

- Electrical shock
- Electrically-caused fire
- Injury caused by hazardous substances
- Mechanically-caused injury
- Skin burn
- Radiation-caused injury

On-board DC/DC converters, Power interface modules and DC/DC regulators are defined as component power supplies. As components they cannot fully comply with the provisions of any safety requirements without "conditions of acceptability". Clearance between conductors and between conductive parts of the component power supply and conductors on the board in the final product must meet the applicable safety requirements. Certain conditions of acceptability apply for component power supplies with limited stand-off (see Mechanical Information for further information). It is the responsibility of the installer to ensure that the final product housing these components complies with the requirements of all applicable safety standards and regulations for the final product.

Component power supplies for general use shall comply with the requirements in IEC/EN/UL 62368-1. Product related standards, e.g. IEEE 802.3af *Power over Ethernet*, and ETS-300132-2 *Power interface at the input to telecom equipment, operated by direct current (dc)* are based on IEC/EN/UL 60950-1 with regards to safety.

Flex Power DC/DC converters, Power interface modules and DC/DC regulators are UL 62368-1 recognized and certified in accordance with EN 62368-1. The flammability rating for all construction parts of the products meet requirements for V-0 class material according to IEC 60695-11-10, *Fire hazard testing, test flames – 50 W horizontal and vertical flame test methods*.

Isolated DC/DC converters

The product may provide basic or functional insulation between input and output according to IEC/EN/UL 62368-1 (see Safety Certificate), different conditions shall be met if the output of a basic or a functional insulated product shall be considered as ES1 energy source.

For basic insulated products (see Safety Certificate) the output is considered as ES1 energy source if one of the

following conditions is met:

- The input source provides supplementary or double or reinforced insulation from the AC mains according to IEC/EN/UL 62368-1.
- The input source provides functional or basic insulation from the AC mains and the product's output is reliably connected to protective earth according to IEC/EN/UL 62368-1.

For functional insulated products (see Safety Certificate) the output is considered as ES1 energy source if one of the following conditions is met:

- The input source provides double or reinforced insulation from the AC mains according to IEC/EN/UL 62368-1.
- The input source provides basic or supplementary insulation from the AC mains and the product's output is reliably connected to protective earth according to IEC/EN/UL 62368-1.
- The input source is reliably connected to protective earth and provides basic or supplementary insulation according to IEC/EN/UL 62368-1 and the maximum input source voltage is 60 Vdc.

Galvanic isolation between input and output is verified in an electric strength test and the isolation voltage (V_{iso}) meets the voltage strength requirement for basic insulation according to IEC/EN/UL 62368-1.

It is recommended to use a slow blow fuse at the input of each DC/DC converter. If an input filter is used in the circuit the fuse should be placed in front of the input filter. In the rare event of a component problem that imposes a short circuit on the input source, this fuse will provide the following functions:

- Isolate the fault from the input power source so as not to affect the operation of other parts of the system
- Protect the distribution wiring from excessive current and power loss thus preventing hazardous overheating

BMR492 series DC-DC Converters Input
40 - 60 V, Output up to 42 A / 504 W

28701-BMR49203 03 revB May 2021
© Flex

Absolute Maximum Ratings

Characteristics		min	typ	max	Unit
T _{P1}	Operating Temperature (see Thermal Consideration section)	-40		+125	°C
T _S	Storage temperature	-55		+125	°C
V _I	Input voltage	-0.5		+65	V
C _{out}	Output capacitance	470		10000	µF
V _{iso}	Isolation voltage (input to output)			2250	Vdc
V _{iso}	Isolation voltage (input to baseplate)			1500	Vdc
V _{iso}	Isolation voltage (baseplate to output)			750	Vdc
V _{tr}	Input voltage transient (t _p 100 ms)			+80	V
V _{RC}	Remote Control pin voltage	-0.3		5	V

Stresses above those listed under Absolute Maximum Ratings may cause permanent damage to the device. This is a stress rating only; functional operation of the device at these or any other conditions above those indicated in the Electrical Specification section of this specification is not implied. Exposure to absolute maximum rating conditions for extended periods may affect device reliability.

Fundamental Circuit Diagram

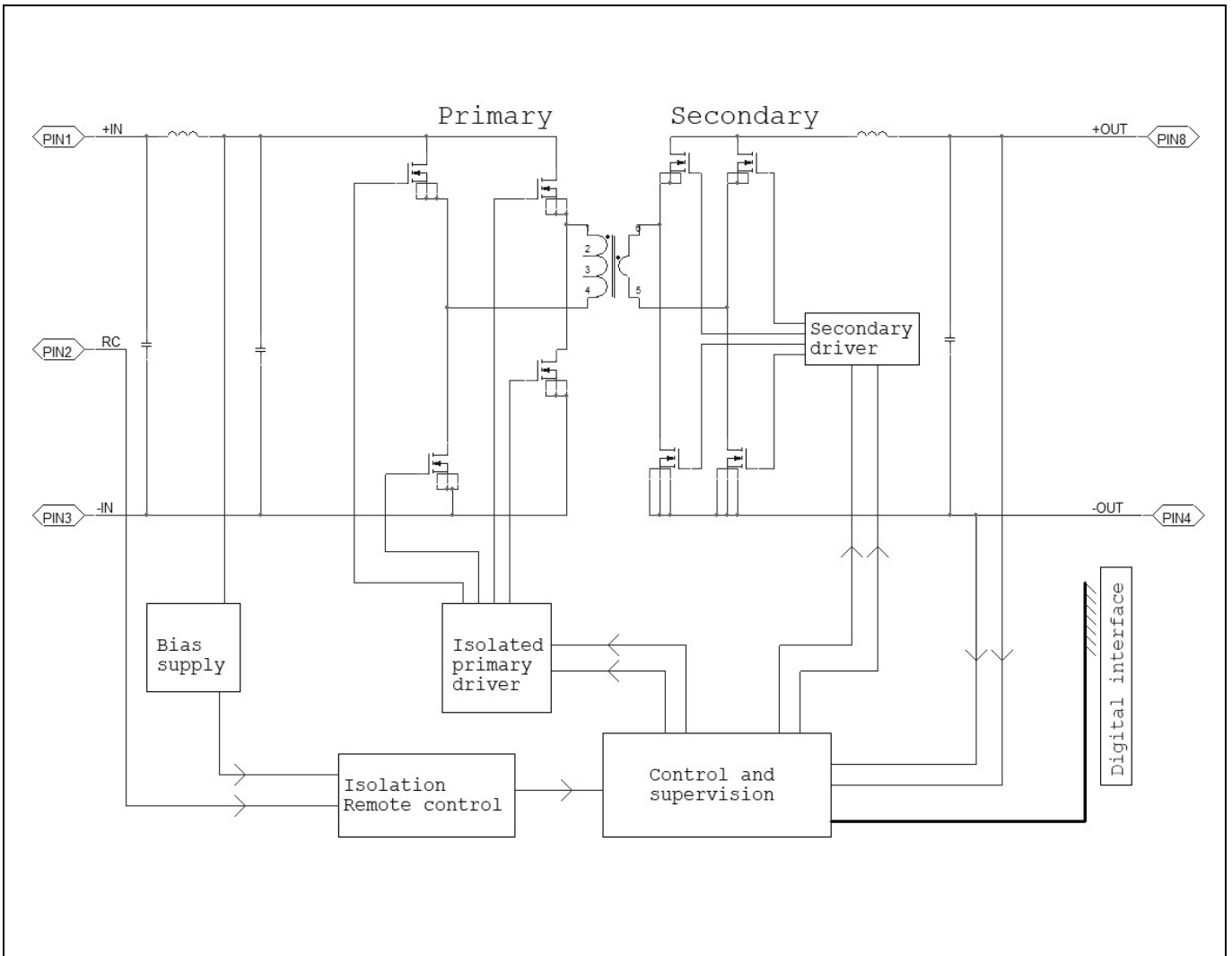

BMR492 series DC-DC Converters Input
 40 - 60 V, Output up to 42 A / 504 W

28701-BMR49203 03 revB May 2021

© Flex

Common Electrical Specification

This section includes parameter specifications common to all product versions within the product series. Typically these are parameters defined by the digital controller of the products. In the table below PMBus commands for configurable parameters are written in capital letters.

T_{P1} = -30 to +90 °C, V_I = 40 to 60 V, unless otherwise specified under Conditions.

Typical values given at: T_{P1} = +25 °C, V_I = 53 V, max I_O , unless otherwise specified under Conditions:

BMR492XXX3/862

Characteristics		Conditions	min	typ	max	Unit
$f_{SW} = 1/T_{SW}$	Switching Frequency			220		kHz
	Switching Frequency Range, Note 1	PMBus configurable FREQUENCY_SWITCH	200		240	kHz
	Switching Frequency Set-point Accuracy	$T_{P1} = +25\text{ °C}$	-5		+5	%
	External Sync Pulse Width		N/A			ns
	Input Clock Frequency Drift Tolerance	External sync	-5		+5	%

T_{INIT}	Initialization Time	From $V_I > \sim 27\text{ V}$ to ready to be enabled		10		ms
T_{ONdel_tot}	Output voltage Total On Delay Time	Enable by input voltage		$T_{INIT} + T_{ONdel}$		
		Enable by RC or CTRL pin		T_{ONdel}		
T_{ONdel}	Output voltage On Delay Time	PMBus configurable Turn on delay duration		15		ms
		Range TON_DELAY, Note 2	0		1023	ms
		Accuracy (actual delay vs set value)		± 1		%
T_{OFFdel}	Output voltage Off Delay Time	PMBus configurable Turn off delay duration, Note 3		0		ms
		Range TOFF_DELAY	0		1023	ms
		Accuracy (actual delay vs set value),		± 1		%
$T_{ONrise} / T_{OFFfall}$	Output voltage On/Off Ramp Time (0-100%-0 of V_O)	Turn on ramp duration		10		ms
		Turn off ramp duration	Disabled in standard configuration. Turn off immediately upon expiration of Turn off delay.			ms
		Range TON_RISE/TOFF_FALL	0		1023	ms
		Ramp time accuracy for standalone operation (actual ramp time vs set value)	-5		+5	%
V_{loff}	Input turn off range	States the level where the output voltage is disabled, PMBus configurable	30	35	60	V
V_{lon}	Input turn on range	States the level where the output voltage is enabled, PMBus configurable.	30	37	60	V

BMR492 series DC-DC Converters Input
40 - 60 V, Output up to 42 A / 504 W

28701-BMR49203 03 revB May 2021
© Flex

Characteristics		Conditions	min	typ	max	Unit
Power Good , PG	PG threshold	PMBus configurable Rising		8		V _O
		PMBus configurable Falling		5		V _O
	PG thresholds range	POWER_GOOD_ON VOUT_UV_FAULT_LIMIT	0		100	% V _O
	PG delay	From V _O reaching target to PG assertion		30		us

Input Under Voltage Protection, IUVP	IUVP threshold	PMBus configurable		35		V	
	IUVP threshold range	VIN_UV_FAULT_LIMIT		0-100		%V _{IN}	
	IUVP hysteresis	PMBus configurable		1		V	
	IUVP hysteresis range	VIN_UV_FAULT_LIMIT- VIN_UV_WARN_LIMIT		1		V	
	Set point accuracy			±2		%	
	IUVP response delay			30		µs	
	Fault response	PMBus configurable VIN_UV_FAULT_RESPONSE		Disable, do not retry			
Input Over Voltage Protection, IOVP	IOVP threshold	PMBus configurable		85		V	
	IOVP threshold range	VIN_OV_FAULT_LIMIT		0-100		%V _{IN}	
	IOVP hysteresis	PMBus configurable VIN_OV_FAULT_LIMIT- VIN_OV_WARN_LIMIT		20		V	
	IOVP hysteresis range	VIN_OV_WARN_LIMIT		0-100		%V _{IN}	
	Set point accuracy			±2		%	
	IOVP response delay			30		µs	
	Fault response	PMBus configurable VIN_OV_FAULT_RESPONSE		Disable, retry continuously			
Output Voltage Over/Under Voltage Protection, OVP/UVP	UVP threshold	PMBus configurable		0		V _O	
	UVP threshold range	VOUT_UV_FAULT_LIMIT		0-100		%V _O	
	OVP threshold	PMBus configurable		15.6		V _O	
	OVP threshold range	VOUT_OV_FAULT_LIMIT		0-16		V _O	
	UVP/OVP response time			70		µs	
	Fault response	PMBus configurable VOUT_UV_FAULT_RESPONSE		Ignore fault			
		PMBus configurable VOUT_OV_FAULT_RESPONSE		Disable, retry continuously			
Over Current Protection, OCP Note 5	OCP threshold	PMBus configurable		50		A	
	OCP threshold range	IOUT_OC_FAULT_LIMIT	0		255	A	
	Protection delay	See Note 4		0		ms	
	Fault response	PMBus configurable IOUT_OC_FAULT_RESPONSE, see Note 6		Disable, retry continuously, 1 ms delay.			
Over Temperature Protection, OTP Note 7	OTP threshold	PMBus configurable		130		°C	
	OTP threshold range	OT_FAULT_LIMIT	-50		+150	°C	
	OTP hysteresis	PMBus configurable OT_FAULT_LIMIT- OT_WARN_LIMIT		40		°C	
	Fault response	PMBus configurable OT_FAULT_RESPONSE		Disable, restart continuously when fault no longer exist @ ~90°C on the temperature sensor.			
Under Current Protection, UCP	UCP threshold	PMBus configurable		-40		A	
	UCP threshold range	IOUT_UC_FAULT_LIMIT	-128		127	A	
	Protection delay	See Note 4		0		ms	
	Fault response	PMBus configurable IOUT_UC_FAULT_RESPONSE, see Note 6		Disable, do not retry.			

BMR492 series DC-DC Converters Input
 40 - 60 V, Output up to 42 A / 504 W

28701-BMR49203 03 revB May 2021

© Flex

Characteristics		Conditions	min	typ	max	Unit
Monitoring Accuracy	Input voltage READ_VIN			±125		mV
	Output voltage READ_VOUT			±40		mV
	Output current READ_IOUT	$T_{P1} = 25\text{ °C}, V_O = 12.0\text{ V}$		±0.5		A
		$T_{P1} = -30 - 125\text{ °C}, V_O = 12.0\text{ V}$		±1		A
	Duty cycle READ_DUTY_CYCLE		No tolerance, Read value is the actual value applied by PWM controller			
Temperature READ_TEMPERATURE_1	Temperature sensor, -30- 125 °C		±5		°C	

Current difference between products in a current sharing group	Steady state operation		N/A	
Supported number of products in a current sharing group			N/A	

V_{OL}	Logic output low signal level	SCL, SDA, SYNC, GCB, SALERT, PG Sink/source current = 4 mA		0.25	V
V_{OH}	Logic output high signal level		2.7		V
I_{OL}	Logic output low sink current			4	mA
I_{OH}	Logic output high source current			4	mA
V_{IL}	Logic input low threshold	SCL, SDA, CTRL, SYNC		1.1	V
V_{IH}	Logic input high threshold		2.1		V
$C_{I\text{ PIN}}$	Logic pin input capacitance	SCL, SDA, CTRL, SYNC		10	pF
RC_{S_PU}	Secondary Remote Control logic pin internal pull-up resistance	SCL, SDA, SALERT	No internal pull-up		
		CTRL to +3.3V	10		kΩ
f_{SMB}	Supported SMBus Operating frequency		100	400	kHz
T_{BUF}	SMBus Bus free time	STOP bit to START bit See section SMBus – Timing		1.3	μs
t_{set}	SMBus SDA setup time from SCL	See section SMBus – Timing		100	ns
t_{hold}	SMBus SDA hold time from SCL	See section SMBus – Timing		0	ns
	SMBus START/STOP condition setup/hold time from SCL			600	ns
T_{low}	SCL low period		1.3		μs
T_{high}	SCL high period		0.6	50	μs

Note 1. There are configuration changes to consider when changing the switching frequency, see section Switching Frequency.

Note 2. When setting 0 ms and start with V_{in} the actual delay will be 15 ms due to boot up of the control circuit.

Note 3. Commanded to stop with T_{OFF_FALL} time with the ON_OFF_CONFIG programmed to soft off.

Note 4. According to the combination of command delay time in FW_CONFIG_FAULTS and delay time unit in $IOUT_OC_FAULT_RESPONSE$ and $IOUT_UC_FAULT_RESPONSE$, see Appendix – PMBus commands.

Note 5. Note that higher OCP threshold than specified may result in damage of the module at OC fault conditions.

Note 6. In the total delay time for $IOUT_OC_FAULT_RESPONSE$ the TON_DELAY is included. For current setting see Appendix – PMBus commands

Note 7. See section Over Temperature Protection (OTP).

BMR492 series DC-DC Converters Input
 40 - 60 V, Output up to 42 A / 504 W

28701-BMR49203 03 revB May 2021

© Flex

Electrical Specification
12 V, 42 A / 500 W
BMR 492 xxx3/862
 $T_{P1} = -30$ to $+90^{\circ}\text{C}$, $V_I = 40$ to 60 V, unless otherwise specified under Conditions.

 Typical values given at: $T_{P1} = +25^{\circ}\text{C}$, $V_I = 53$ V, I_O max, unless otherwise specified under Conditions.

 Additional $C_{in} = 220$ μF , $C_{out} = 470$ μF . See Operating Information section for selection of capacitor types.

Characteristics		Conditions	min	typ	max	Unit
V_I	Input voltage range		40		60	V
V_{loff}	Turn-off input voltage	Decreasing input voltage	34	35	36	V
V_{lon}	Turn-on input voltage	Increasing input voltage	36	37	38	V
C_I	Internal input capacitance			30		μF
P_O	Output power		0		500	W
η	Efficiency	50% of max I_O		96		%
		max I_O		96.6		
		50% of max I_O , $V_I = 48$ V		96.4		
		max I_O , $V_I = 48$ V		96.8		
P_d	Power Dissipation	max I_O		17	22	W
P_{li}	Input idling power	$I_O = 0$ A, $V_I = 53$ V		6.5		W
P_{RC}	Input standby power	$V_I = 53$ V (turned off with RC)		0.53		W
f_s	Switching frequency	0-100 % of max I_O see Note 1	209	220	231	kHz

V_{Oi}	Output voltage initial setting and accuracy	$T_{P1} = +25^{\circ}\text{C}$, $V_I = 53$ V, $P_O = 0$ W	11.94	12	12.06	V
V_O	Output adjust range	See operating information	8		13.2	V
	Output voltage tolerance band	0-100% of max I_O	11.76		12.24	V
	Idling voltage	$I_O = 0$ A	11.9		12.12	V
	Line regulation	$V_I = 40 - 60$ V max I_O		3	10	mV
	Load regulation	$V_I = 53$ V, 0-100% of max I_O		10	35	mV
V_{tr}	Load transient voltage deviation	$V_I = 53$ V, Load step 25-75-25% of max I_O , $di/dt = 5$ A/ μs		± 250	± 740	mV
t_{tr}	Load transient recovery time	see Note 2		50	75	μs
t_r	Ramp-up time (from 10-90% of V_{Oi})	0-100% of max I_O	9	10	11	ms
t_s	Start-up time (from V_I connection to 100% of V_{Oi})	see Note 3	32	40	48	ms
t_{RC}	RC start-up time (from V_{RC} connection to 100% of V_{Oi})	max I_O , see Note 3		25	33	ms
RC	Sink current	See operating information	0.4			mA
	Trigger level	Decreasing / Increasing RC-voltage		0.8		V
	Response time		0.1	0.2	0.3	ms
I_O	Output current		0		42	A
I_{lim}	Current limit threshold	$T_{P1} < \max T_{P1}$	53	60	65	A
I_{sc}	Short circuit current	$T_{P1} = 25^{\circ}\text{C}$, see Note 4		5.6	7	A
C_{out}	Recommended Capacitive Load	$T_{P1} = 25^{\circ}\text{C}$	470		10000	μF
V_{Oac}	Output ripple & noise	See ripple & noise section, V_{Oi}		50	130	mVp-p
OVP	Over voltage protection	$T_{P1} = +25^{\circ}\text{C}$, $V_I = 53$ V, 0-100% of max I_O		15.6	15.8	V

Note 1: For higher values, contact FAE.

 Note 2: $C_{out} = 2$ mF (2 x 1 mF; 16SEPC, Panasonic, low ESR, Polymer cap). ESR is highly temperature dependent for some types of capacitors e.g. aluminum electrolyte capacitors will freeze in cold environment.

Note 3: PMBus command TON_DELAY set to 15ms included.

Note 4: Hiccup short circuit protection; RMS output current is the presented

BMR492 series DC-DC Converters Input
40 - 60 V, Output up to 42 A / 504 W

28701-BMR49203 03 revB May 2021

© Flex

Typical Characteristics 12 V, 42 A / 500 W

BMR 492 xxx3/862

Efficiency

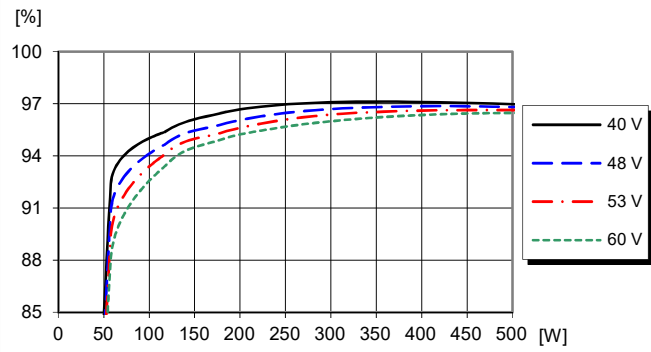

Efficiency vs. output power and input voltage at $T_{P1} = +25^{\circ}\text{C}$.

Power Dissipation

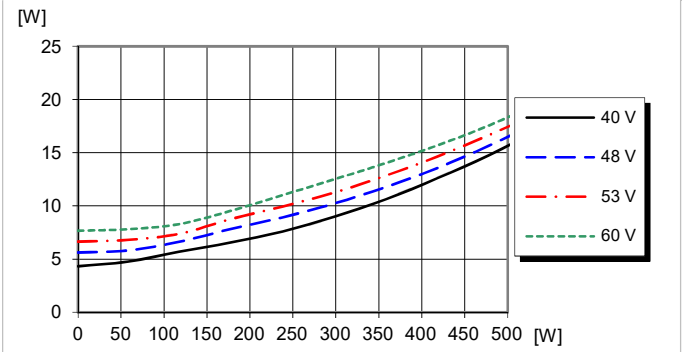

Dissipated power vs. output power and input voltage at $T_{P1} = +25^{\circ}\text{C}$.

Output Characteristics

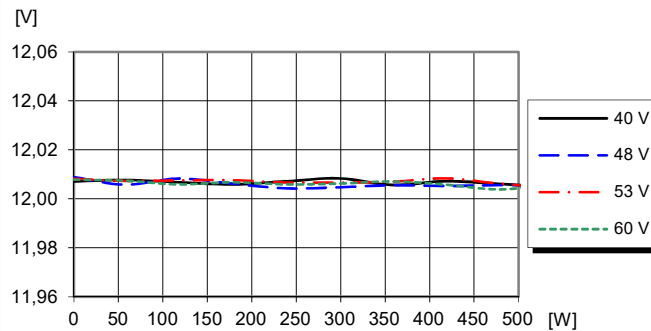

Output voltage vs. output power and input voltage at $T_{P1} = +25^{\circ}\text{C}$.

Output Characteristics

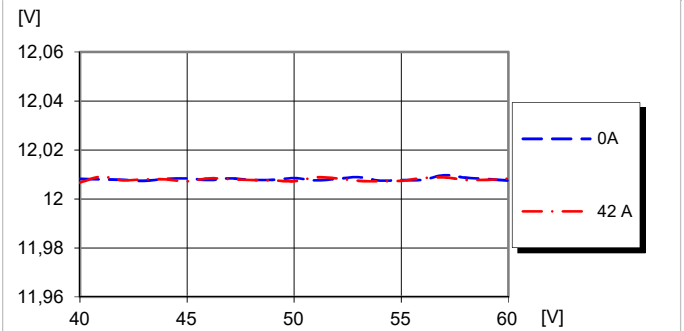

Output voltage vs. input voltage and load current at $T_{P1} = +25^{\circ}\text{C}$.

Current Limit Characteristics

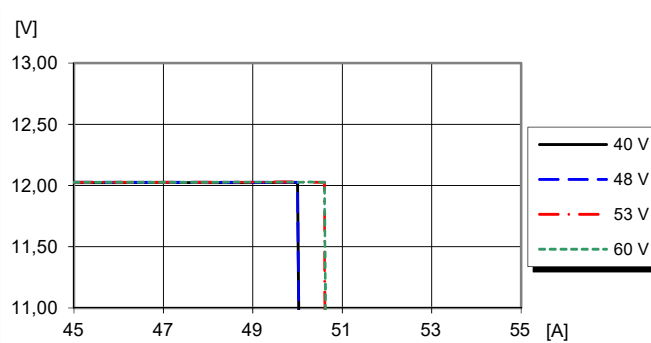

Output voltage vs. load current and input voltage at $I_o > \text{max } I_o$, $T_{P1} = +25^{\circ}\text{C}$.

Available Power

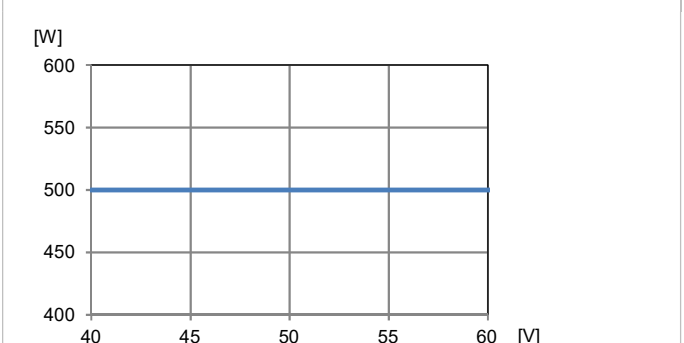

Output power vs. input voltage at $T_{P1} = +25^{\circ}\text{C}$.

BMR492 series DC-DC Converters Input
40 - 60 V, Output up to 42 A / 504 W

28701-BMR49203 03 revB May 2021

© Flex

Typical Characteristics

12 V, 42 A / 500 W

BMR 492 xxx3/862

Start-up

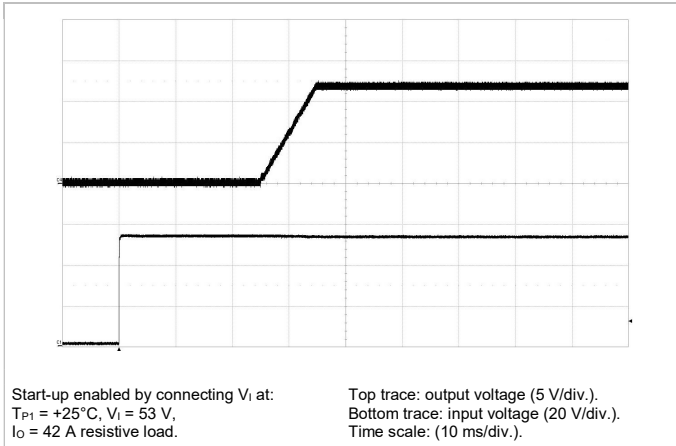

Shut-down

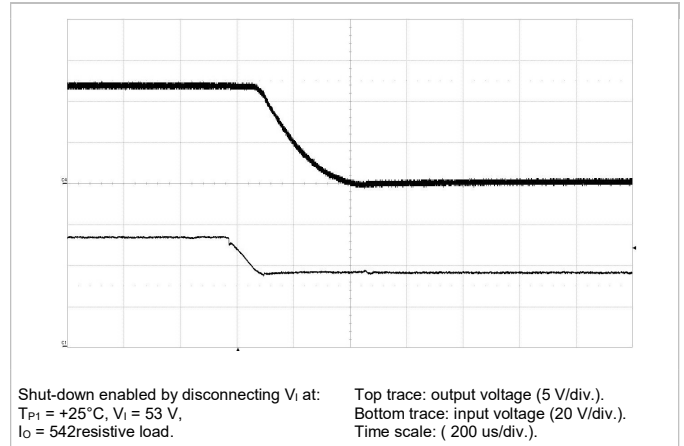

Output Ripple & Noise

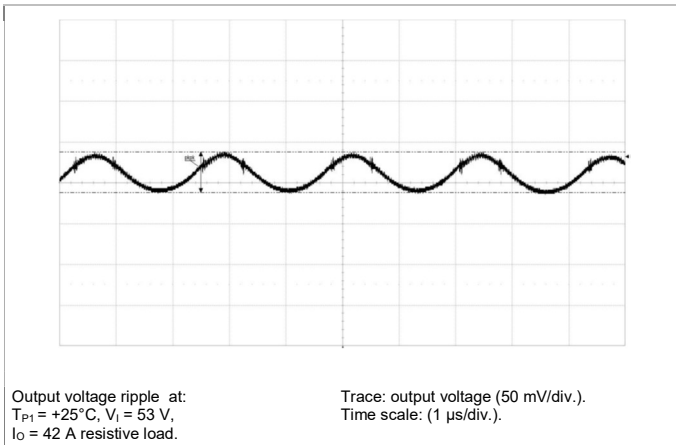

Output Load Transient Response

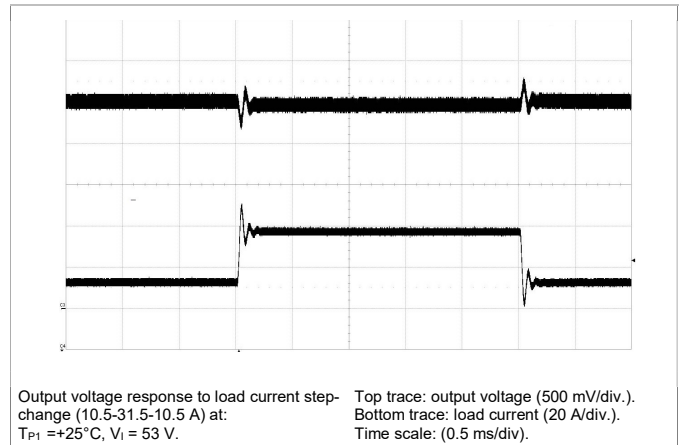

BMR492 series DC-DC Converters Input
40 - 60 V, Output up to 42 A / 504 W

28701-BMR49203 03 revB May 2021
© Flex

Typical Characteristics

12 V, 42 A / 500 W

BMR 492 xxx3/862

Output Power Derating – Baseplate

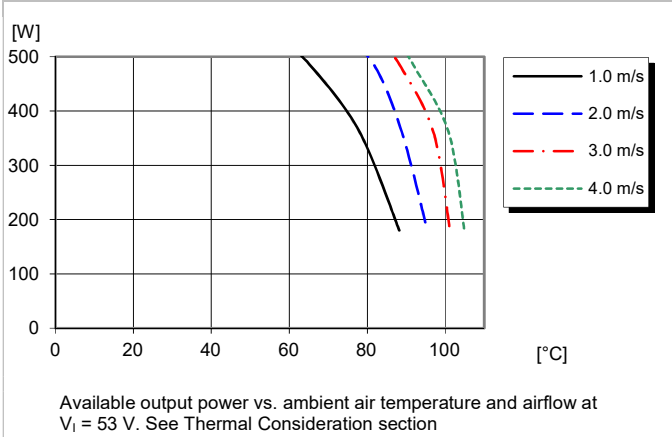

Output Power Derating – Open Frame

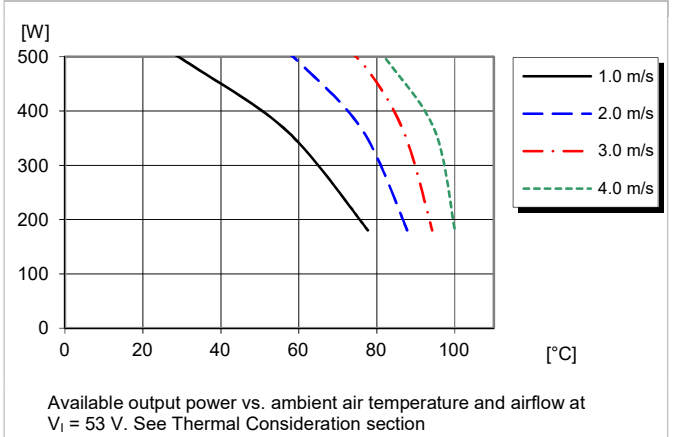

Output Power Derating – 1" Heatsink

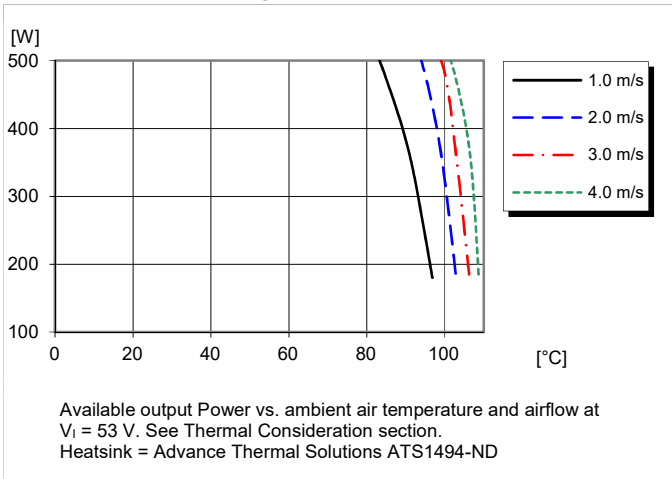

Thermal Resistance – Base plate

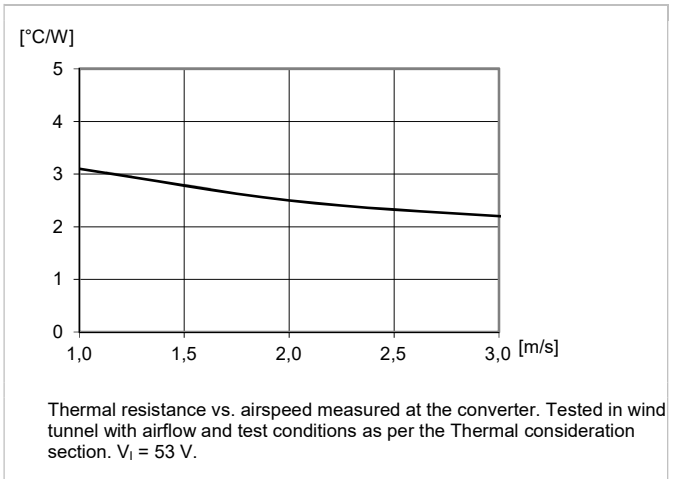

Maximum Output Power

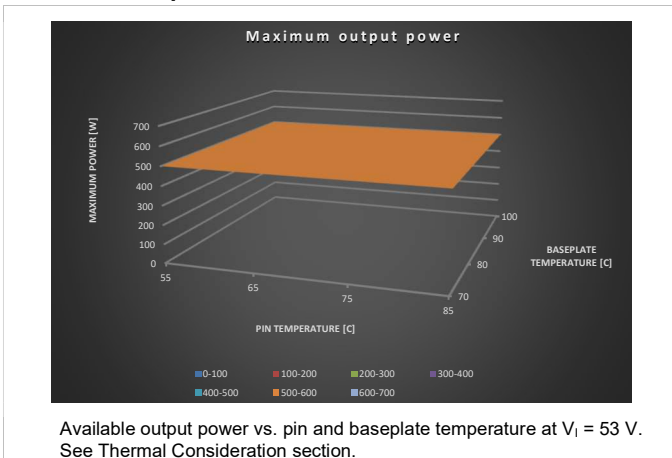

BMR492 series DC-DC Converters Input
40 - 60 V, Output up to 42 A / 504 W

28701-BMR49203 03 revB May 2021

© Flex

EMC Specification

Conducted EMI measured according to EN55022 / EN55032, CISPR 22 / CISPR 32 and FCC part 15J (see test set-up). The fundamental switching frequency is 220 kHz for BMR492. The EMI characteristics below is measured at $V_i = 53$ V and max I_o .

Conducted EMI Input terminal value (typ)

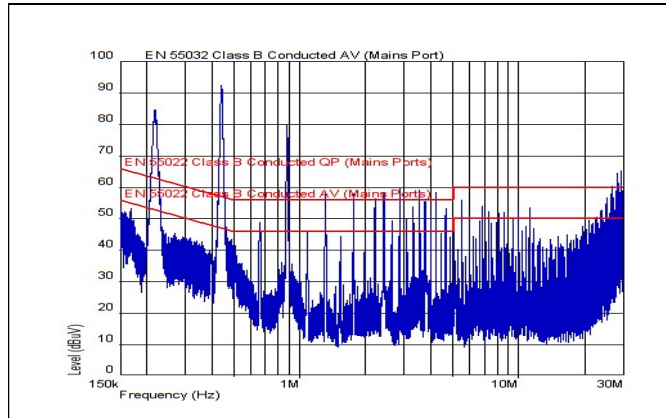

EMI without filter. EN55032 Test method and limits are the same as EN55022. 470 μ F 100V input capacitor and 470 μ F 16 V OS-CON output capacitor used.

Optional external filter for class B

Suggested external input filter in order to meet class B in EN55022 / EN55032, CISPR 22 / CISPR 32 and FCC part 15J.

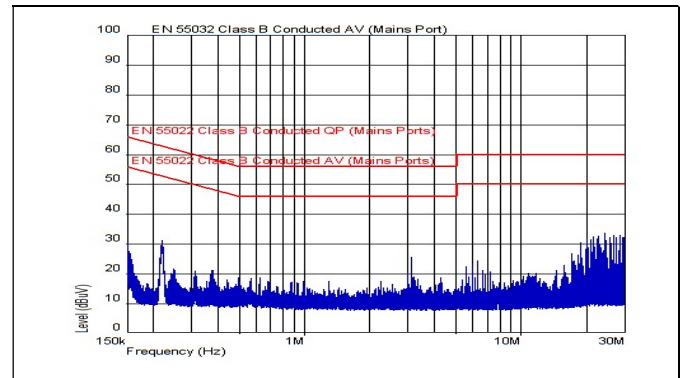
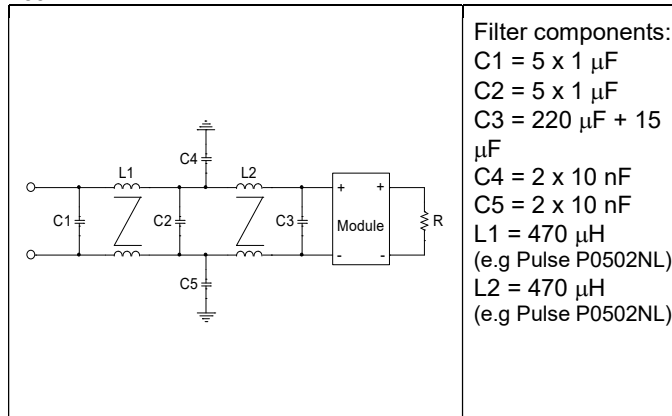

EMI with filter, EN55032. Test method and limits are the same as EN55022.

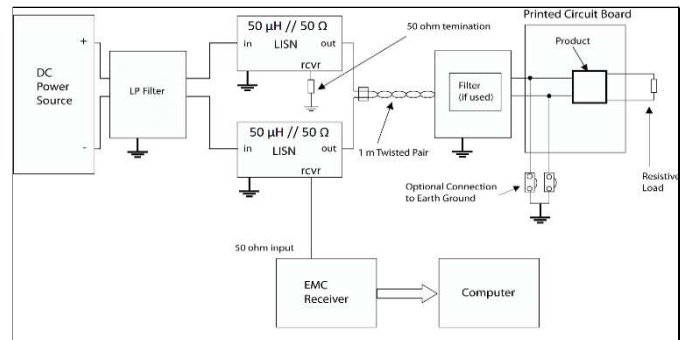

Test set-up

Layout recommendations

The radiated EMI performance of the product will depend on the PWB layout and ground layer design. It is also important to consider the stand-off of the product. If a ground layer is used, it should be connected to the output of the product and the equipment ground or chassis.

A ground layer will increase the stray capacitance in the PWB and improve the high frequency EMC performance.

Output ripple and noise

Output ripple and noise measured according to figure below. See Design Note 022 for detailed information.

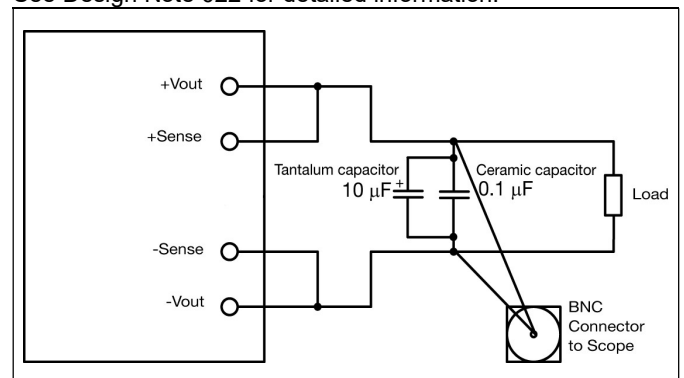

Output ripple and noise test setup

BMR492 series DC-DC Converters Input
40 - 60 V, Output up to 42 A / 504 W

28701-BMR49203 03 revB May 2021
© Flex

Power Management Overview

This product is equipped with a PMBus interface. The product incorporates a wide range of readable and configurable power management features that are simple to implement with a minimum of external components. Additionally, the product includes protection features that continuously safeguard the load from damage due to unexpected system faults. A fault is also shown as an alert on the SALERT pin. The following product parameters can continuously be monitored by a host: Input voltage, output voltage/current, duty cycle and internal temperature.

The product is delivered with a default configuration suitable for a wide range operation in terms of input voltage, output voltage, and load. The configuration is stored in an internal Non-Volatile Memory (NVM). All power management functions can be reconfigured using the PMBus interface

Throughout this document, different PMBus commands are referenced. A detailed description of each command is provided in the appendix at the end of this specification.

The Flex Power Designer software suite can be used to configure and monitor this product via the PMBus interface. For more information please contact your local Flex sales representative.

SMBus Interface

This product provides a PMBus digital interface that enables the user to configure many aspects of the device operation as well as to monitor the input and output voltages, output current and device temperature. The product can be used with any standard two-wire I²C (master must allow for clock stretching) or SMBus host device. In addition, the product is compatible with PMBus version 1.3 and includes an SALERT line to help mitigate bandwidth limitations related to continuous fault monitoring. The product supports 100 kHz and 400 kHz bus clock frequency only. The PMBus signals, SCL, SDA and SALERT require passive pull-up resistors as stated in the SMBus Specification. Pull-up resistors are required to guarantee the rise time as follows:

$$\text{Eq. 7 } \tau = R_p C_p \leq 1\mu s$$

where R_p is the pull-up resistor value and C_p is the bus load. The maximum allowed bus load is 400 pF. The pull-up resistor should be tied to an external supply between 2.7 to 3.8 V, which should be present prior to or during power-up. If the proper power supply is not available, voltage dividers may be applied. Note that in this case, the resistance in the equation above corresponds to parallel connection of the resistors forming the voltage divider.

It is recommended to always use PEC (Packet Error Check) when communicating via PMBus.

PMBus Addressing

The following figure and table show recommended resistor values with min and max voltage range for hard-wiring PMBus addresses (series E96, 1% tolerance resistors suggested):

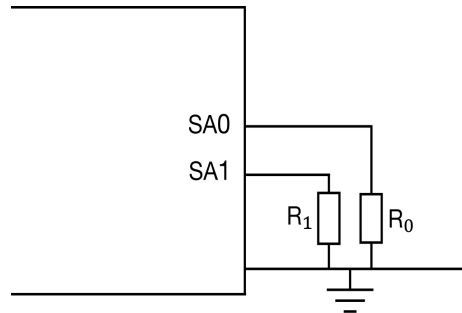

Schematic of connection of address resistors

SA0/SA1 Index	R _{SA0} / R _{SA1} [kΩ]
0	10
1	15.4
2	23.7
3	36.5
4	54.9
5	84.5
6	130
7	200

The SA0 and SA1 pins can be configured with a resistor to GND according to the following equation.

$$\text{PMBus Address} = 8 \times (\text{SA1 index}) + (\text{SA0 index})$$

PMBus base address offset value is configured via PMBus command 0xC9. Specific variants may already have a default non-zero value set for PMBus base address offset.

Configuring the address setup by command FW_CONFIG_PMBUS (0xC9), see section Offset Address.

The allowed range of the PMBus address is: 1-126 excluding 12 and 16. When the calculated PMBus address falls outside the allowed range address 126 is assigned instead. It is not recommended to keep the SA0/SA1 pins left open.

BMR492 series DC-DC Converters Input
40 - 60 V, Output up to 42 A / 504 W

28701-BMR49203 03 revB May 2021

© Flex

I²C/SMBus – Timing

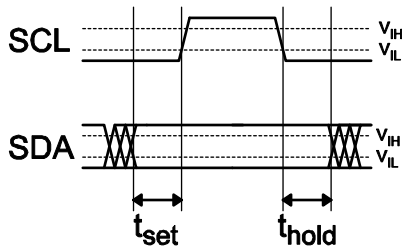

Setup and hold times timing diagram

The setup time, t_{set} , is the time data, SDA, must be stable before the rising edge of the clock signal, SCL. The hold time t_{hold} , is the time data, SDA, must be stable after the rising edge of the clock signal, SCL. If these times are violated incorrect data may be captured or meta-stability may occur and the bus communication may fail. All standard SMBus protocols must be followed, including clock stretching. This product supports the BUSY flag in the status commands to indicate product being too busy for SMBus response. A bus-free time delay between every SMBus transmission (between every stop & start condition) must occur. Refer to the SMBus specification, for SMBus electrical and timing requirements. Note that an additional delay of 5 ms has to be inserted in case of storing the RAM content into the internal non-volatile memory.

Monitoring via PMBus

It is possible to continuously monitor a wide variety of parameters through the PMBus interface. These include, but are not limited to, the parameters listed in the table below.

Parameter	PMBus Command
Input voltage	READ_VIN
Output voltage	READ_VOUT
Output current	READ_IOUT
Temperature *	READ_TEMPERATURE_1
Switching Frequency	READ_FREQUENCY
Duty cycle	READ_DUTY_CYCLE

*Reports the temperature from temperature sensor set in command 0xDC, internal (controller IC)/external (temp sensor).

Monitoring Faults

Fault conditions can be detected using the SALERT pin, which will be asserted low when any number of pre-configured fault or warning conditions occurs. The SALERT pin will be held low until faults and/or warnings are cleared by the CLEAR_FAULTS(0x03) command, or until the output voltage has been re-enabled. It is possible to mask which fault conditions should not assert the SALERT pin by the command SMBALERT_MASK(0x1B). In response to the SALERT signal, the user may read a few status commands to find out what fault or warning condition occurred, see table below.

Fault & Warning Status	PMBus Command
Overview, Power Good	STATUS_BYTE STAU_STATUS_WORD
Output voltage level	STATUS_VOUT
Output current level	STATUS_IOUT
Input voltage level	STATUS_INPUT
Temperature level	STATUS_TEMPERATURE
PMBus communication	STATUS_CML
Miscellaneous	STATUS_MFR_SPECIFIC

Non-Volatile Memory (NVM)

The product incorporates two Non-Volatile Memory areas for storage of the PMBus command values; the Default NVM and the User NVM. The Default NVM is pre-loaded with Flex factory default values. The Default NVM is write-protected and can be used to restore the Flex factory default values through the command RESTORE_DEFAULT_ALL (0x12). The User NVM is pre-loaded with Flex factory default values. The User NVM is writable and open for customization. The values in NVM are loaded during initialization according to section Initialization Procedure, where after commands can be changed through the PMBus Interface.

The User NVM is implemented with one-time programmable memory (OTP). Changes to the default configuration can be stored to User NVM using the command STORE_USER_ALL(0x15) which writes configuration changes in RAM to the OTP memory.

It is important to note that the one-time programmable memory (OTP) is limited, and frequent use of the STORE_USER_ALL command will lead to memory space exhaustion. The actual number of writes to NVM depends on a number of variables that makes it difficult to provide a precise number. Writes to NVM should be limited to less than 20 updates.

Operating Information

Input Voltage

The input voltage range 40 to 60 Vdc meets the requirements for normal input voltage range in -48 Vdc systems, -40.5 to -57.0 V. At input voltages exceeding 60 V, the power loss will be higher than at normal input voltage and T_{P1} must be limited to absolute max +125°C. The absolute maximum continuous input voltage is 65 Vdc.

Short duration transient disturbances can occur on the DC distribution and input of the product when a short circuit fault occurs on the equipment side of a protective device (fuse or circuit breaker). The voltage level, duration and energy of the disturbance are dependent on the particular DC distribution network characteristics and can be sufficient to damage the product unless measures are taken to suppress or absorb this energy. The transient voltage can be limited by capacitors and other energy absorbing devices like zener diodes connected across the positive and negative input conductors at strategic

BMR492 series DC-DC Converters Input 40 - 60 V, Output up to 42 A / 504 W	28701-BMR49203 03 revB May 2021
	© Flex

points in the distribution network. The end-user must secure that the transient voltage will not exceed the value stated in the Absolute maximum ratings. ETSI TR 100 283 examines the parameters of DC distribution networks and provides guidelines for controlling the transient and reduce its harmful effect.

Turn-on and -off Input Voltage

The product monitors the input voltage and will turn on and turn off at configured thresholds (see Electrical Specification). The turn-on input voltage threshold is set higher than the corresponding turn-off threshold. Hence, there is a hysteresis between turn-on and turn-off input voltage levels.

Remote Control (RC)

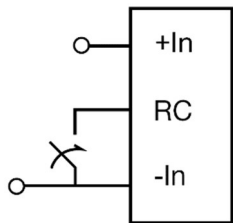

The products are fitted with a remote control function referenced to the primary negative input connection (-In), with negative logic options available. The RC function allows the product to be turned on/off by an external device like a semiconductor or mechanical switch.

The RC pin has an internal pull up resistor.

The external device must provide a minimum required sink current >0.5 mA to guarantee a voltage not higher than maximum voltage on the RC pin (see Electrical characteristics table). To turn off the product the RC pin should be left open for a minimum time of 150 μ s, the same time requirement applies when the product shall turn on. When the RC pin is left open, the voltage generated on the RC pin is max 5 V. The standard product is provided with "negative logic" RC and will be off until the RC pin is connected to the -In. To turn off the product the RC pin should be left open. In situations where it is desired to have the product to power up automatically without the need for control signals or a switch, the RC pin shall be wired directly to -In.

Remote Control (secondary side)

The CTRL pin (Pin 9) can be configured as remote control in combination with hardware and PMBus configuration. With hardware option, Pin 9 used for secondary remote control, Power Good is disabled. The secondary remote control uses an internal pull-up resistor. The logic options for the secondary remote control can be positive or negative logic. The logic option for the secondary remote control is easily configured via ON_OFF_CONFIG (0x02) using Flex Power Designer software command.

Input and Output Impedance

The impedance of both the input source and the load will interact with the impedance of the product. It is important that the input source has low characteristic impedance. Minimum recommended external input capacitance is 100 μ F. The electrolytic capacitors will be degraded in low temperature.

The needed input capacitance in low temperature should be equivalent to 100 μ F at 20°C. The performance in some applications can be enhanced by addition of external capacitance as described under External Decoupling Capacitors. If the input voltage source contains significant inductance, the addition of a low ESR ceramic capacitor of 22 – 100 μ F capacitor across the input of the product will ensure stable operation. The minimum required capacitance value depends on the output power and the input voltage. The higher output power the higher input capacitance is needed. A minor leakage current in standby mode might over time build up a few volts if not taken care of with external load.

External Decoupling Capacitors

When powering loads with significant dynamic current requirements, the voltage regulation at the point of load can be improved by addition of decoupling capacitors at the load. The most effective technique is to locate low ESR ceramic and electrolytic capacitors as close to the load as possible, using several parallel capacitors to lower the effective ESR. The ceramic capacitors will handle high-frequency dynamic load changes while the electrolytic capacitors are used to handle low frequency dynamic load changes. It is equally important to use low resistance and low inductance PWB layouts and cabling.

External decoupling capacitors will become part of the product's control loop. The control loop is optimized for a wide range of external capacitance and the maximum recommended value that could be used without any additional analysis is found in the Electrical specification.

The ESR of the capacitors is a very important parameter. Stable operation is guaranteed with a verified ESR value of >1 m Ω across the output connections.

For further information please contact your local Flex Power Modules representative.

PMBus configuration and support

The product provides a PMBus digital interface that enables the user to configure many aspects of the device operation as well as monitor the input and output parameters.

The Flex Power Designer software suite can be used to configure and monitor this product via the PMBus interface. For more information, please contact your local Flex sales representative.

Feed Forward Capability

The BMR492 products have a Feed Forward function implemented that can handle sudden input voltage changes. The output voltage will be regulated during an input transient and will typically stay within 10% when an input transient is applied. The Feed Forward acts on both positive and negative input voltage transients.

Output Voltage Adjust using PMBus

BMR492 series DC-DC Converters Input
 40 - 60 V, Output up to 42 A / 504 W

28701-BMR49203 03 revB May 2021

© Flex

The output voltage of the product can be reconfigured via PMBus command VOUT_COMMAND (0x21) or VOUT_TRIM (0x22). This can be used when adjusting the output voltage above or below output voltage initial setting up to a certain level, see Electrical specification for adjustment range. When increasing the output voltage, the voltage at the output pins must be kept within the plotted area, see graph below. Output voltage setting must be kept below the threshold of the over voltage protection, (OVP) to prevent the product from shutting down. At increased output voltages the maximum power rating of the product remains the same, and the max output current must be decreased correspondingly. According to below graph the BMR492 is operating at max duty cycle where the output voltage start to droop.

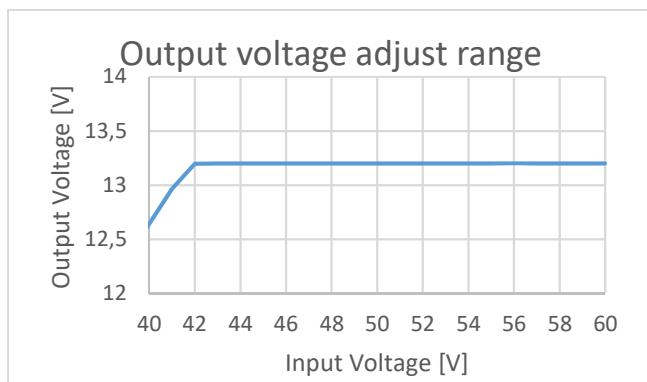

Margin Up/Down Controls

These controls allow the output voltage to be momentarily adjusted, either up or down, by a nominal 10%. The margin high and margin low shall be limited to max and min output voltage, if the nominal output voltage is changed. This provides a convenient method for dynamically testing the operation of the load circuit over its supply margin or range. It can also be used to verify the function of supply voltage supervisors. The margin up and down levels of the product can easily be re-configured using Flex Power Designer software.

Soft-start Power Up

The default rise time for a single product is 10 ms. When starting by applying input voltage the control circuit boot-up time adds an additional total delay of 25 ms, including configurable 15ms TON_DELAY (0x60). The soft-start and soft-stop control functionality allows the output voltage to ramp-up and ramp-down with defined timing with respect to the control of the output. This can be used to control inrush current and manage supply sequencing of multiple controllers. The rise time is the time taken for the output to ramp to its target voltage, while the fall time is the time taken for the output to ramp down from its regulation voltage to 0 V. The TON_DELAY (0x60) time sets a delay from when the output is enabled until the output voltage starts to ramp up. The TOFF_DELAY (0x64) delay time sets a delay from when the output is disabled until the output voltage starts to ramp down.

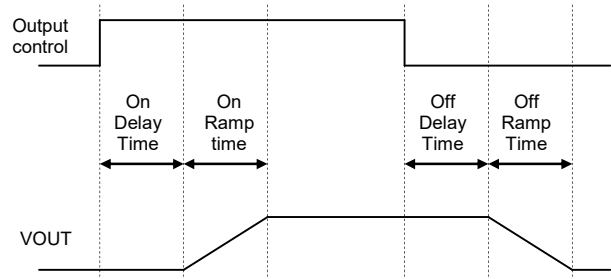

Illustration of Soft-Start and Soft-Stop.

By default, soft-stop is disabled, and the regulation of output voltage stops immediately when the output is disabled. Soft-stop can be enabled through the PMBus command ON_OFF_CONFIG (0x02). The delay and ramp times can be reconfigured using the PMBus commands TON_DELAY (0x60), TON_RISE (0x61), TOFF_DELAY (0x64) and TOFF_FALL (0x65).

Pre-bias Start-up

The product has a Pre-bias start up functionality and will not sink current during start up if a pre-bias source is present at the output terminals. If the Pre-bias voltage is lower than the target value set in VOUT_COMMAND (0x21), the product will ramp up to the target value. If the Pre-bias voltage is higher than the target value set in VOUT_COMMAND (0x21), the product will ramp down to the target value and in this case sink current. It is recommended to keep TON_RISE below 100ms.

Over/Under Temperature Protection (OTP, UTP)

The products are protected from thermal overload by an internal over temperature sensor.

The product will make continuous attempts to start up (non-latching mode) and resume normal operation automatically when the temperature has dropped below the temperature threshold set in command OT_WARN_LIMIT (0x51).

The OTP and hysteresis of the product can be re-configured using the PMBus interface. The product has also an under-temperature protection. The OTP and UTP fault limit and fault response can be configured via the PMBus. Note: using the fault response "continue without interruption" may cause permanent damage to the product.

Input Over/Under Voltage Protection (OVP)

The product can be protected from high input voltage and low input voltage by a pre-configured value with a response time of ~30us. The over/under-voltage fault level and fault response is easily configured using Flex Power Designer software, see also Appendix – PMBus commands.

Output Over Voltage Protection (OVP)

The product includes over voltage limiting circuitry for protection of the load. The default OVP limit is 30% above the nominal output voltage. If the output voltage exceeds the OVP limit, the product can respond in different ways.

BMR492 series DC-DC Converters Input 40 - 60 V, Output up to 42 A / 504 W	28701-BMR49203 03 revB May 2021
	© Flex

The default response from an over voltage fault is to immediately shut down, with a response time of ~70us. The device will continuously check for the presence of the fault condition, and when the fault condition no longer exists the device will be re-enabled.

The OVP fault level and fault response can be configured via the PMBus interface, see Appendix – PMBus commands.

Over Current Protection (OCP)

The products include current limiting circuitry for protection at continuous overload. For standard configuration the output voltage will decrease towards $0.25 \times V_{out}$, set in command IOUT_OC_LV_FAULT_LIMIT (0x48), then shutdown and automatic restart (hiccup mode) for output currents in excess of max output current (max Io). The product will resume normal operation after removal of the overload. The load distribution should be designed for the maximum output short circuit current specified.

The over current protection of the product can be configured via the PMBus interface, see Appendix – PMBus commands.

Switching frequency

The switching frequency is set to 220kHz as default but this can be reconfigured via the PMBus interface. The product is optimized at this frequency, but can run at lower and higher frequency (200kHz-240kHz). The electrical performance can be affected if the switching frequency is changed.

Power Good

The power good pin 9 (PG) indicates when the product is ready to provide regulated output voltage to the load. During ramp-up and during a fault condition, PG is held high. By default, PG is asserted low after the output has ramped to a voltage above 8V, and de-asserted if the output voltage falls below 5V. These thresholds may be changed using the PMBus commands POWER_GOOD_ON (0x5E) and POWER_GOOD_OFF (0x5F).

By default, the PG pin is configured as Push/pull output. The polarity is by default configured to active low.

The product provides Power Good flag in the Status Word register that indicates the output voltage is within a specified tolerance of its target level and no-fault condition exists.

Address Offset

The command FW_CONFIG_PMBUS (0xC9) can be configured to utilize different address offset option. There are 3 different address setting option.

- 1) The bit 16 in command 0xC9 must be set to 1 to enable PMBus address offset via resistors.
- 2) The resistor address offset in combination with a value set by PMBus base address offset, [31:24] in command FW_CONFIG_PMBUS (0xC9). This can be chosen when 1 address resistor is used.

- 3) A pre-configured PMBus address, [23:17] in FW_CONFIG_PMBUS (0xC9). The bit 16 in command 0xC9 must be set to 0 to enable digital PMBus address offset. The digital PMBus address offset in combination with a digital PMBus base address offset, [31:24] in command FW_CONFIG_PMBUS (0xC9) adds a larger range of address possibilities. This combination can be chosen if no address resistors are used.

The PMBus-address offset's with resistor value increments the address value following the formula in the PMBus Addressing section of documentation. This increases flexibility when the part is used in single-pin and no-pin addressing scenarios.

See Appendix – PMBus commands.

BMR492 series DC-DC Converters Input
40 - 60 V, Output up to 42 A / 504 W

28701-BMR49203 03 revB May 2021

© Flex

Thermal Consideration

General

The products are designed to operate in different thermal environments and sufficient cooling must be provided to ensure reliable operation.

For products mounted on a PWB without a heat sink attached, cooling is achieved mainly by conduction, from the pins to the host board, and convection, which is dependent on the airflow across the product. Increased airflow enhances the cooling of the product. The Output Current Derating graph found in the Output section for each model provides the available output current vs. ambient air temperature and air velocity at $V_I = 53$ V.

For products using any form of heat sink structure a top spacing board and side airflow guides are used to ensure airflow hitting the module and not diverted away. Distance between the tested device and the top space board and the side airflow guides are $6.35\text{mm} \pm 1\text{mm}$.

The product is tested on a 254×254 mm, $35 \mu\text{m}$ (1 oz), 16-layer test board mounted vertically in a wind tunnel.

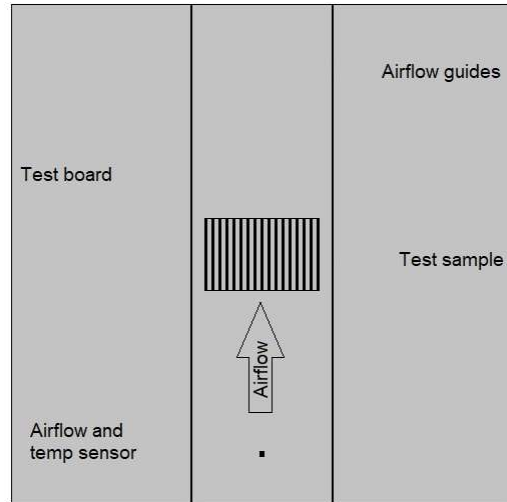
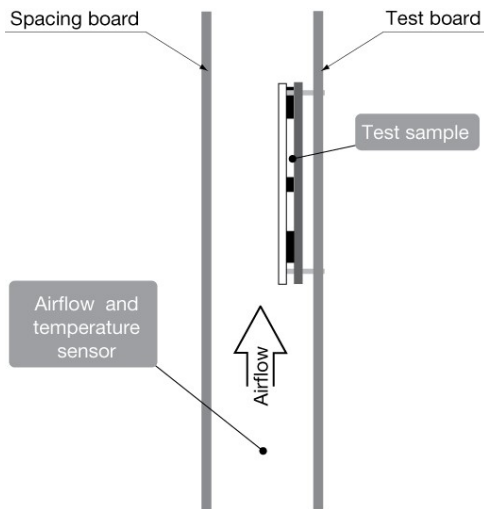

For products with base plate used in a sealed box/cold wall application, cooling is achieved mainly by conduction through the cold wall. The Output Power Derating graphs are found in the Output section for each model. The product is tested in a sealed box test set up with ambient temperatures 85°C . See Design Note 028 for further details.

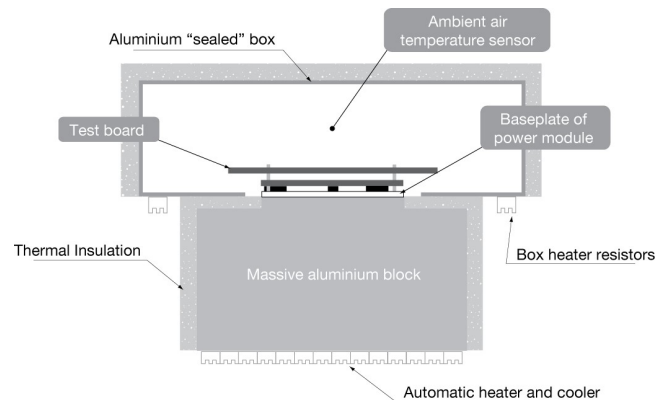

Definition of product operating temperature

The product operating temperatures is used to monitor the temperature of the product, and proper thermal conditions can be verified by measuring the temperature at position P1. The temperature at these positions (T_{P1}) should not exceed the maximum temperatures in the table below. The number of measurement points may vary with different thermal design and topology. Temperatures above maximum T_{P1} , measured at the reference point P1 are not allowed and may cause permanent damage.

BMR492 series DC-DC Converters Input
40 - 60 V, Output up to 42 A / 504 W

28701-BMR49203 03 revB May 2021

© Flex

Position	Description	Max Temp.
P1	MOSFET CASE	$T_{P1}=125^{\circ}\text{C}$

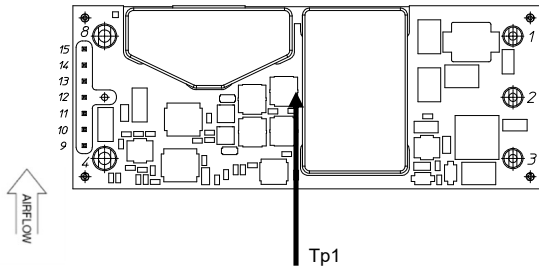

Base plate (Bottom view)

Ambient Temperature Calculation

For products with base plate the maximum allowed ambient temperature can be calculated by using the thermal resistance.

- The power loss is calculated by using the formula $((1/\eta) - 1) \times \text{output power} = \text{power losses (Pd)}$.
 η = efficiency of product. E.g. 96% = 0.96
- Find the thermal resistance (Rth) in the Thermal Resistance graph found in the Output section for each model. **Note that the thermal resistance can be reduced if a heat sink is mounted on the top of the base plate.**

Calculate the temperature increase (ΔT).

$$\Delta T = R_{th} \times P_d$$

- Max allowed ambient temperature is:

$$\text{Max } T_{P1} - \Delta T.$$

E.g. BMR 492 0302/862 at 2.0m/s:

$$1. \left(\frac{1}{0.961}\right) - 1 \times 500 \text{ W} = 18.3 \text{ W}$$

$$2. 18.3 \text{ W} \times 2.5^{\circ}\text{C/W} = 46^{\circ}\text{C}$$

$$3. 125^{\circ}\text{C} - 46^{\circ}\text{C} = \text{max ambient temperature is } 79^{\circ}\text{C}$$

- The thermal performance can be improved by mounting a heat sink on top of the base plate.

The actual temperature will be dependent on several factors such as the PWB size, number of layers and direction of airflow.

Connections (Bottom view)

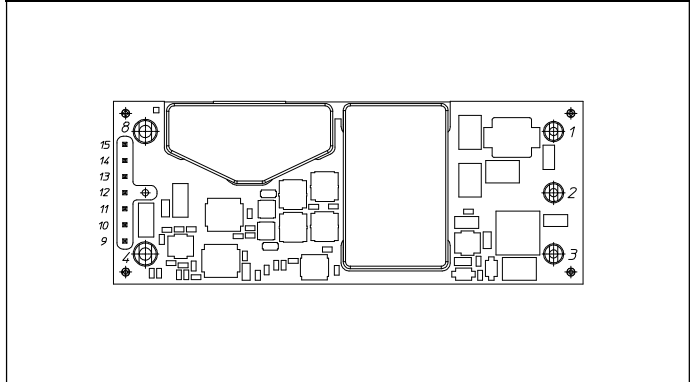

Pin	Designation	Function
1	+In	Positive Input
2	RC	Remote Control
3	-In	Negative Input
4	-Out	Negative Output
8	+Out	Positive Output
9	PG/*CTRL	Power Good
10	DGND	PMBus ground
11	SDA	PMBus Data
12	SALERT	PMBus alert signal
13	SCL	PMBus Clock
14	SA1	PMBus Address 1
15	SA0	PMBus Address 0

*Pin 9 secondary remote control, set by hardware

BMR492 series DC-DC Converters Input
40 - 60 V, Output up to 42 A / 504 W

28701-BMR49203 03 revB May 2021

© Flex

Mechanical Information - Hole mount, Press fit Baseplate version, BMR 492 x3 02 / xxx

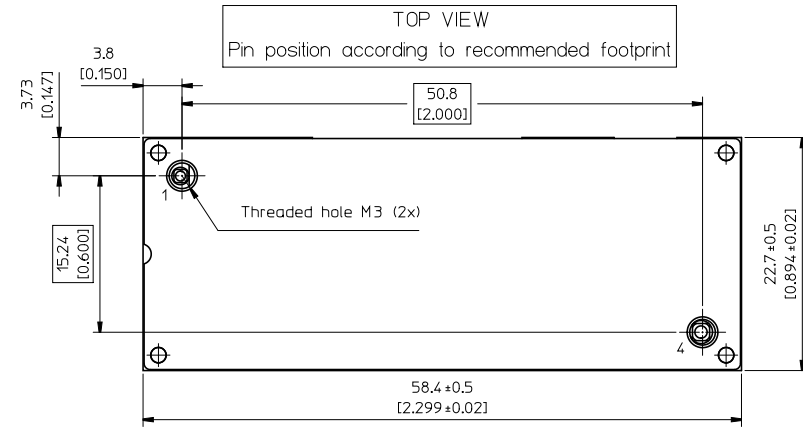
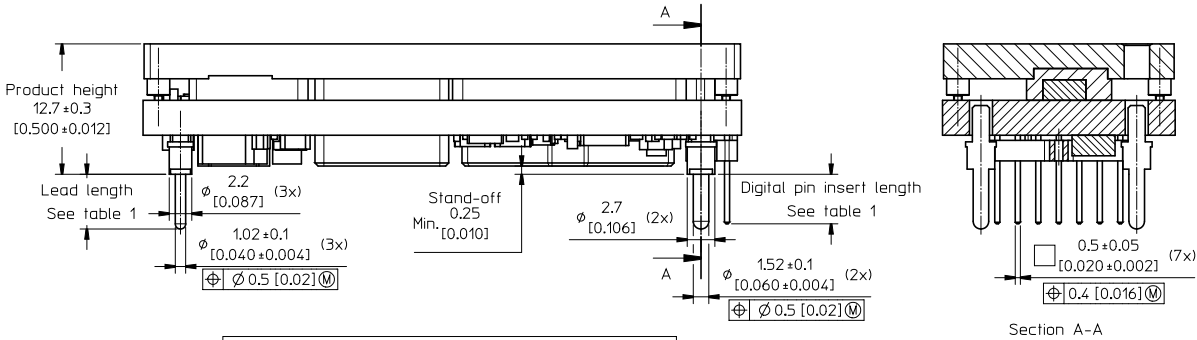

Pin option	Lead length	Digital pin insert length
Std.	5.33 [0.210]	4.83 [0.190]
LA	3.69 [0.145]	3.19 [0.126]
LB	4.57 [0.180]	4.01 [0.158]
LC	2.79 [0.110]	2.29 [0.090]

Table 1

PIN SPECIFICATIONS

Pin 1-8 material: Copper alloy
Plating: Min Au 0.1 µm over Ni 1-3 µm
Pin 9-15 material: Brass
Plating: Min Au 0.2 µm over 1-3 µm

CASE

Material: Aluminium
For screw attachment apply mounting torque of max 0.44 Nm [3.9 lbf in]. M3 screw must not protrude more than 3.1 mm [0.122] into the baseplate.

Recommended hole dimensions are only for reference. It is the end users decision based on different situations like production processes, substrate thickness etc.

Weight: Typical 47.9 g
All dimensions in mm [inch].
Tolerances unless specified
x.x mm ±0.5 mm [0.02]
x.xx mm ±0.25 mm [0.01]
(Not applied on footprint or typical values)

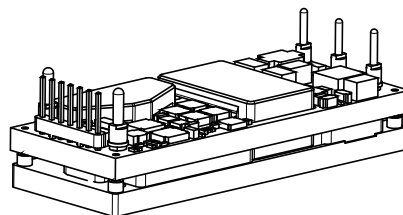
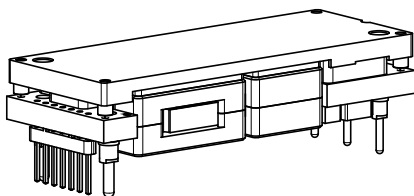
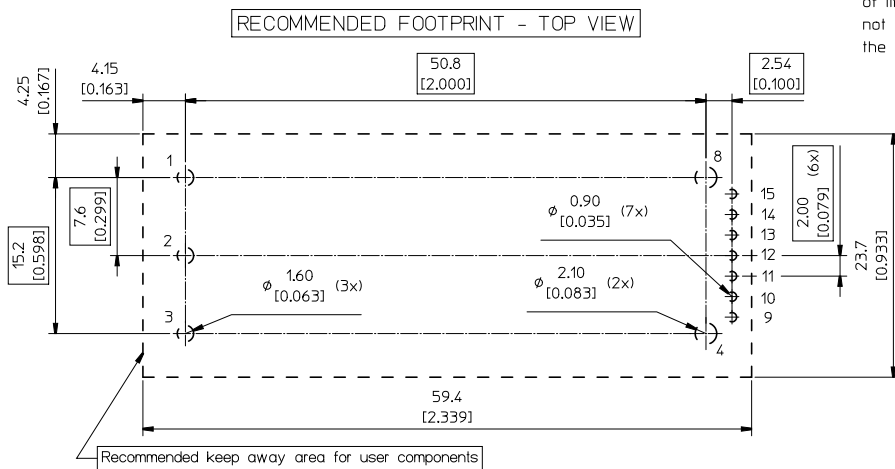

BMR492 series DC-DC Converters Input
40 - 60 V, Output up to 42 A / 504 W

28701-BMR49203 03 revB May 2021

© Flex

Soldering Information – Hole Mount through Pin in Paste Assembly

The pin in paste mount product is intended for forced convection or vapor phase reflow soldering in SnPb and Pb-free processes.

Reflow soldering is not preferred for through-hole mounted power modules due to challenges resulting in reduced reliability. High temperature reflow soldering causing IMC layer thickness increase resulting in shorten solder joint lifetime. To avoid component or solder failure a module peak temperature higher than 245 degrees and above 217 degrees more than 90 seconds is not recommended. To prevent re-melt of module internal solder joints shielding cap is required during reflow process.

A no-clean flux is recommended to avoid entrapment of cleaning fluids in cavities inside the product or between the product and the host board, since cleaning residues may affect long time reliability and isolation voltage.

General reflow process specifications		SnPb eutectic	Pb-free
Average ramp-up ($T_{PRODUCT}$)		3°C/s max	3°C/s max
Typical solder melting (liquidus) temperature	T_L	183°C	221°C
Minimum reflow time above T_L	T_{PIN}	60 s	60 s
Minimum pin temperature	T_{PIN}	210°C	235°C
Peak product temperature	$T_{PRODUCT}$	225°C	245°C
Average ramp-down ($T_{PRODUCT}$)		6°C/s max	6°C/s max
Maximum time 25°C to peak		6 minutes	8 minutes

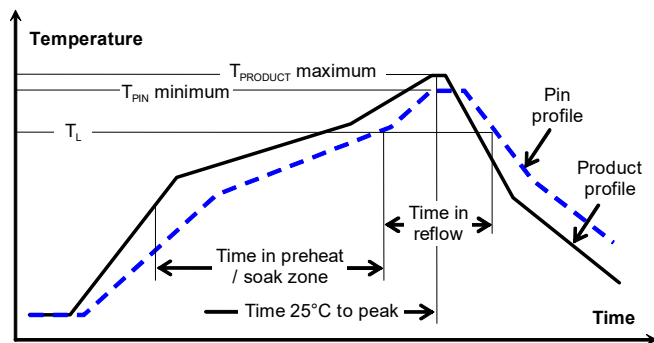

Thermocoupler Attachment

$T_{PRODUCT}$ is measured on the base plate top side, since this will likely be the warmest part of the product during the reflow process.

T_{PIN} temperature is measured on the power module pins solder joints at customer board.

Product reflow classification

The product has been tested for the following

Pb-free solder classification

For Pb-free solder processes, the product is qualified for MSL 3 according to IPC/JEDEC standard J-STD-020C.

Product reflow processes

SnPb solder processes

For SnPb solder processes, a pin temperature (T_{PIN}) in excess of the solder melting temperature, (T_L , 183°C for Sn63Pb37) for more than 60 seconds and a peak temperature of 220°C is recommended to ensure a reliable solder joint.

For dry packed products only: depending on the type of solder paste and flux system used on the host board, up to a recommended maximum temperature of 245°C could be used, if the products are kept in a controlled environment (dry pack handling and storage) prior to assembly.

Lead-free (Pb-free) solder processes

For Pb-free solder processes, a pin temperature (T_{PIN}) in excess of the solder melting temperature (T_L , 217 to 221°C for SnAgCu solder alloys) for more than 60 seconds and a peak temperature of 245°C on all solder joints is recommended to ensure a reliable solder joint.

Dry Pack Information

Products intended for Pb-free reflow soldering processes are delivered in standard moisture barrier bags according to IPC/JEDEC standard J-STD-033 (Handling, packing, shipping and use of moisture/reflow sensitivity surface mount devices).

Using products in high temperature Pb-free soldering processes requires dry pack storage and handling. In case the products have been stored in an uncontrolled environment and no longer can be considered dry, floor life according to MSL 3, the modules must be baked according to J-STD-033.

BMR492 series DC-DC Converters Input
40 - 60 V, Output up to 42 A / 504 W

28701-BMR49203 03 revB May 2021

© Flex

Soldering Information - Hole Mounting

The hole mounted product is intended for plated through hole mounting by wave or manual soldering. The pin temperature is specified to maximum to 270°C for maximum 10 seconds.

A maximum preheat rate of 4°C/s and maximum preheat temperature of 150°C is suggested. When soldering by hand, care should be taken to avoid direct contact between the hot soldering iron tip and the pins for more than a few seconds in order to prevent overheating.

A no-clean flux is recommended to avoid entrapment of cleaning fluids in cavities inside the product or between the product and the host board. The cleaning residues may affect long time reliability and isolation voltage.

Delivery Package Information

The products are delivered in antistatic Foam trays and in antistatic PPE trays (H option in PN, hard tray).

Tray Specifications – Through hole version	
Material	PE Foam, dissipative
Surface resistance	$10^5 < \text{Ohm/square} < 10^{11}$
Bakability	The trays cannot be baked
Tray thickness	18 mm [0.709 inch]
Box capacity	100 products (4 full trays/box) 25 products (1 full tray/box)
Tray weight	45 g empty tray, 1225 g full tray

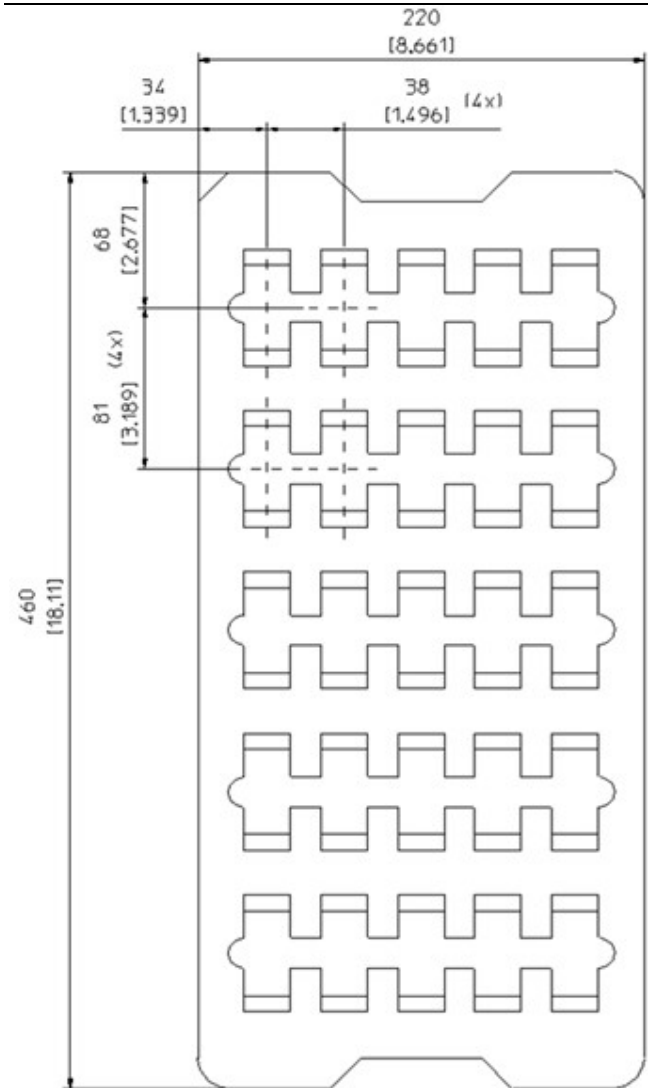

Example PE Foam tray

BMR492 series DC-DC Converters Input
40 - 60 V, Output up to 42 A / 504 W

28701-BMR49203 03 revB May 2021

© Flex

Tray Specifications – Hard Tray (dry pack, pick & place) (“H” option)	
Material	Antistatic PPE
Surface resistance	$10^5 < \text{Ohm/square} < 10^{11}$
Bakeability	The trays can be baked at maximum 125°C for 48 hours
Tray capacity	20 converters/tray
Box capacity	80 products (4 full trays/box)
Weight	212 g empty tray, 1170 g full tray

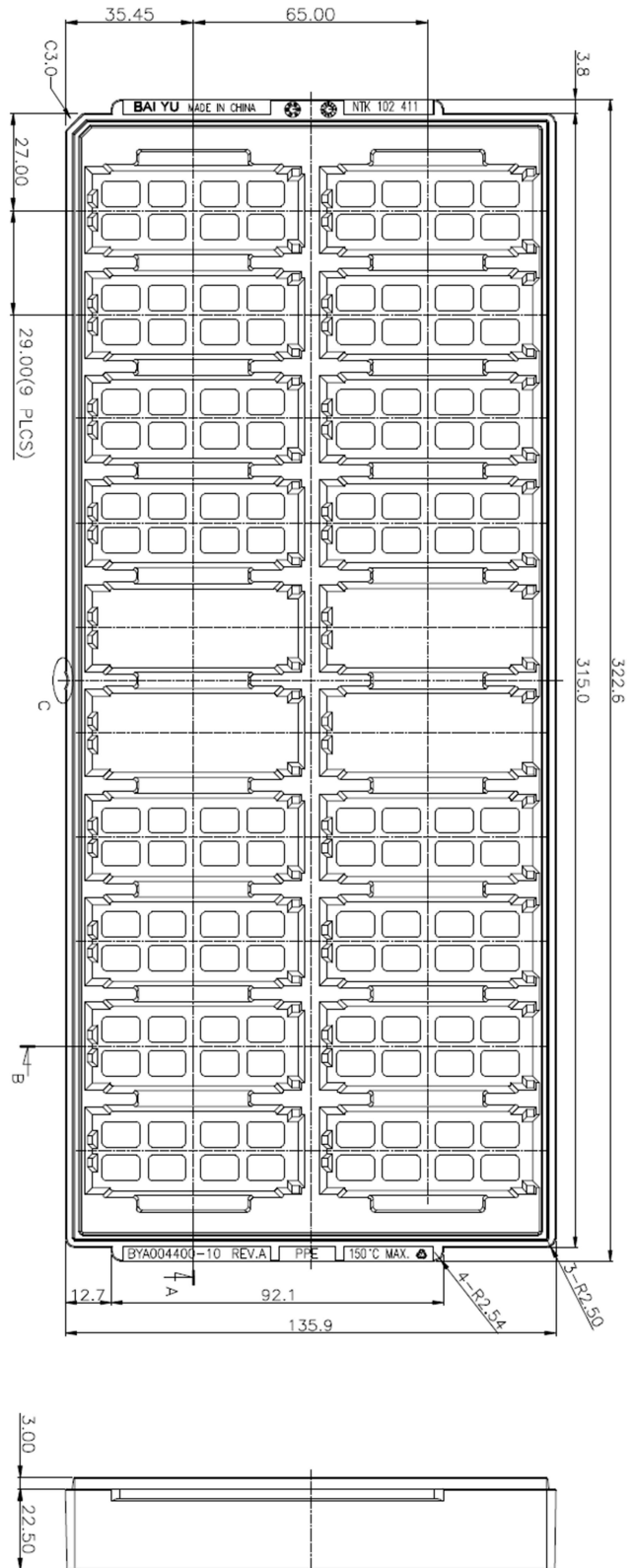

Example Hard tray (20 pcs)

BMR492 series DC-DC Converters Input
 40 - 60 V, Output up to 42 A / 504 W

28701-BMR49203 03 revB May 2021

© Flex

Product Qualification Specification

Characteristics			
External visual inspection	IPC-A-610		
Temperature shock test (Temperature cycling)	IEC 60068-2-14 Na	Temperature range Number of cycles Dwell/transfer time	-40 to 125°C 700 15 min/0-1 min
Cold (in operation)	IEC 60068-2-1 Ad	Temperature T _A Duration	-45°C 72 h
Damp heat	IEC 60068-2-67 Cy	Temperature Humidity Duration	85°C 85 % RH 1000 hours
Dry heat	IEC 60068-2-2 Bd	Temperature Duration	125°C 1000 h
Electrostatic discharge susceptibility	IEC 61340-3-1, JESD 22-A114 IEC 61340-3-2, JESD 22-A115	Human body model (HBM) Machine Model (MM)	Class 2, 2000 V Class 3, 200 V
Immersion in cleaning solvents	IEC 60068-2-45 XA, method 2	Water	55°C
Mechanical shock	IEC 60068-2-27 Ea	Peak acceleration Duration	100 g 6 ms
Moisture reflow sensitivity ¹	J-STD-020E	Level 1 (SnPb-eutectic) Level 3 (Pb Free)	225°C 245°C
Operational Life test Rapid Temp.	MIL-STD-202G, method 108A	Duration	1000 h
Resistance to soldering heat ²	IEC 60068-2-20 Tb, method 1A	Solder temperature Duration	270°C 10-13 s
Robustness of terminations	IEC 60068-2-21 Test Ua1 IEC 60068-2-21 Test Ue1	Through hole mount products Surface mount products	All leads All leads
Solderability	IEC 60068-2-20 test Ta	Preconditioning Temperature, Pb-free	Steam ageing 245°C
Vibration, broad band random	IEC 60068-2-64 Fh, method 1	Frequency Spectral density Duration	10 to 500 Hz 0.07 g ² /Hz 10 min in each direction

Notes

¹ Only for products intended for reflow soldering (surface mount products & pin-in paste³ products)² Only for products intended for wave soldering (plated through hole products)

BMR492 series DC-DC Converters Input 40 - 60 V, Output up to 42 A / 504 W	28701-BMR49203 03 revB May 2021
	© Flex

PMBus Command Appendix

This appendix contains a detailed reference of the PMBus commands supported by the product.

Data Formats

The products make use of a few standardized numerical formats, along with custom data formats. A detailed walkthrough of the above formats is provided in AN304, as well as in sections 7 and 8 of the PMBus Specification Part II. The custom data formats vary depending on the command, and are detailed in the command description.

Standard Commands

The functionality of commands with code 0x00 to 0xCF is usually based on the corresponding command specification provided in the PMBus Standard Specification Part II (see Power System Management Bus Protocol Documents below). However there might be different interpretations of the PMBus Standard Specification or only parts of the Standard Specification applied, thus the detailed command description below should always be consulted.

Forum Websites

The System Management Interface Forum (SMIF)

<http://www.powersig.org/>

The System Management Interface Forum (SMIF) supports the rapid advancement of an efficient and compatible technology base that promotes power management and systems technology implementations. The SMIF provides a membership path for any company or individual to be active participants in any or all of the various working groups established by the implementer forums.

Power Management Bus Implementers Forum
(PMBUS-IF)

<http://pmbus.org/>

The PMBus-IF supports the advancement and early adoption of the PMBus protocol for power management. This website offers recent PMBus specification documents, PMBus articles, as well as upcoming PMBus presentations and seminars, PMBus Document Review Board (DRB) meeting notes, and other PMBus related news.

PMBus – Power System Management Bus Protocol Documents

These specification documents may be obtained from the PMBus-IF website described above. These are required reading for complete understanding of the PMBus implementation. This appendix will not re-address all of the details contained within the two PMBus Specification documents.

Specification Part I – General Requirements Transport And Electrical Interface

Includes the general requirements, defines the transport and electrical interface and timing requirements of hard wired signals.

Specification Part II – Command Language

Describes the operation of commands, data formats, fault management and defines the command language used with the PMBus.

SMBus – System Management Bus Documents

System Management Bus Specification, Version 2.0, August 3, 2000

This specification specifies the version of the SMBus on which Revision 1.2 of the PMBus Specification is based. This specification is freely available from the System Management Interface Forum Web site at:

<http://www.smbus.org/specs/>

BMR492 series DC-DC Converters Input
 40 - 60 V, Output up to 42 A / 504 W

28701-BMR49203 03 revB May 2021

© Flex

PMBus Command Summary and Factory Default Values of Standard Configuration

The factory default values provided in the table below are valid for the Standard configuration. Factory default values for other configurations can be found using the Flex Power Designer tool.

Code	Name	Data Format	Factory Default Value Standard Configuration BMR 492 XX02/861 P1A	
0x01	OPERATION	R/W Byte	0x80	
0x02	ON_OFF_CONFIG	R/W Byte	0x1F	
0x03	CLEAR_FAULTS	Send Byte		
0x10	WRITE_PROTECT	R/W Byte		
0x11	STORE_DEFAULT_ALL	Send Byte		
0x12	RESTORE_DEFAULT_ALL	Send Byte		
0x15	STORE_USER_ALL	Send Byte		
0x16	RESTORE_USER_ALL	Send Byte		
0x19	CAPABILITY	Read Byte		
0x1B	SMBALERT_MASK (STATUS_VOUT)	SMBAlert Mask	0x00	
0x1B	SMBALERT_MASK (STATUS_IOUT)	SMBAlert Mask	0x00	
0x1B	SMBALERT_MASK (STATUS_INPUT)	SMBAlert Mask	0x00	
0x1B	SMBALERT_MASK (STATUS_TEMPERATURE)	SMBAlert Mask	0x00	
0x1B	SMBALERT_MASK (STATUS_CML)	SMBAlert Mask	0x00	
0x1B	SMBALERT_MASK (STATUS_MFR_SPECIFIC)	SMBAlert Mask	0x00	
0x20	VOUT_MODE	Read Byte	0x15	
0x21	VOUT_COMMAND	R/W Word	0x6000	12.0 V
0x22	VOUT_TRIM	R/W Word	0x0000	0.0 V
0x23	VOUT_CAL_OFFSET	R/W Word	Unit Specific	
0x24	VOUT_MAX	R/W Word	0x7333	14.4 V
0x25	VOUT_MARGIN_HIGH	R/W Word	0x699A	13.2 V
0x26	VOUT_MARGIN_LOW	R/W Word	0x5666	10.8 V
0x27	VOUT_TRANSITION_RATE	R/W Word	0xE810	2.0 V/ms
0x28	VOUT_DROOP	R/W Word	0x0000	0.0 mV/A
0x2B	VOUT_MIN	R/W Word	0x0000	0.0 V
0x32	MAX_DUTY	R/W Word	0xF186	97.5 %
0x33	FREQUENCY_SWITCH	R/W Word	0x086E	220.0 kHz
0x35	VIN_ON	R/W Word	0x0025	37.0 V
0x36	VIN_OFF	R/W Word	0x0023	35.0 V
0x37	INTERLEAVE	R/W Word	0x0000	
0x39	IOUT_CAL_OFFSET	Read Word	Unit Specific	
0x40	VOUT_OV_FAULT_LIMIT	R/W Word	0x7CCD	15.6 V
0x41	VOUT_OV_FAULT_RESPONSE	R/W Byte	0xB8	
0x42	VOUT_OV_WARN_LIMIT	R/W Word	0x7800	15.0 V
0x43	VOUT_UV_WARN_LIMIT	R/W Word	0x0001	0.0 V
0x44	VOUT_UV_FAULT_LIMIT	R/W Word	0x0000	0.0 V
0x45	VOUT_UV_FAULT_RESPONSE	R/W Byte	0x00	
0x46	IOUT_OC_FAULT_LIMIT	R/W Word	0x003C	60.0 A
0x47	IOUT_OC_FAULT_RESPONSE	R/W Byte	0xF8	
0x48	IOUT_OC_LV_FAULT_LIMIT	R/W Word	0x1800	3.0 V
0x4A	IOUT_OC_WARN_LIMIT	R/W Word	0x003A	58.0 A
0x4B	IOUT_UC_FAULT_LIMIT	R/W Word	0x07D8	-40.0 A
0x4C	IOUT_UC_FAULT_RESPONSE	R/W Byte	0x80	
0x4F	OT_FAULT_LIMIT	R/W Word	0x0082	130.0 °C
0x50	OT_FAULT_RESPONSE	R/W Byte	0xC0	
0x51	OT_WARN_LIMIT	R/W Word	0x005A	90.0 °C
0x52	UT_WARN_LIMIT	R/W Word	0x0FEC	-40.0 °C
0x53	UT_FAULT_LIMIT	R/W Word	0x0FE7	-50.0 °C
0x54	UT_FAULT_RESPONSE	R/W Byte	0x00	
0x55	VIN_OV_FAULT_LIMIT	R/W Word	0xF154	85.0 V
0x56	VIN_OV_FAULT_RESPONSE	R/W Byte	0xB8	

BMR492 series DC-DC Converters Input
 40 - 60 V, Output up to 42 A / 504 W

28701-BMR49203 03 revB May 2021

© Flex

PMBus Command Details**OPERATION (0x01)**

Description: Sets the desired PMBus enable and margin operations.

Bit	Function	Description	Value	Function	Description
7:6	Enable	Make the device enable or disable.	00	Immediate Off	Disable Immediately without sequencing.
			01	Soft Off	Disable "Softly" with sequencing.
			10	Enable	Enable device to the desired margin state.
5:4	Margin	Select between margin high/low states or nominal output.	00	Nominal	Operate at nominal output voltage.
			01	Margin Low	Operate at margin low voltage set in VOUT_MARGIN_LOW.
			10	Margin High	Operate at margin high voltage set in VOUT_MARGIN_HIGH.
3:2	Act on Fault	Set 10b to act on fault or set to 01b to ignore fault.	01	Ignore Faults	Ignore Faults when in a margined state. The device will ignore appropriate overvoltage/undervoltage warnings and faults and respond as programmed by the warning limit or fault response command.
			10	Act on Faults	Act on Faults when in a margined state. The device will handle appropriate overvoltage/undervoltage warnings and faults and respond as programmed by the warning limit or fault response command.

ON_OFF_CONFIG (0x02)

Description: Configures how the device is controlled by the CONTROL pin and the PMBus.

Bit	Function	Description	Value	Function	Description
4	Powerup Operation	Sets the default to either operate any time power is present or for the on/off to be controlled by CONTROL pin and serial bus commands.	0	Enable Always	Unit powers up any time power is present regardless of state of the CONTROL pin.
			1	Enable pin or PMBus	Unit does not power up until commanded by the CONTROL pin and OPERATION command.
3	PMBus Enable Mode	Controls how the unit responds to commands received via the serial bus.	0	Ignore PMBus	Unit ignores the on/off portion of the OPERATION command from serial bus.
			1	Use PMBus	To start, the unit requires that the on/off portion of the OPERATION command is instructing the unit to run.
2	Enable Pin Mode	Controls how the unit responds to the CONTROL pin.	0	Ignore pin	Unit ignores the CONTROL/Enable pin.
			1	Use pin	Unit requires the CONTROL pin to be asserted to start the unit.
1	Enable Pin Polarity	Polarity of the CONTROL pin.	0	Active Low	Enable pin will cause device to enable when driven low.
			1	Active High	Enable pin will cause device to enable when driven high.
0	Disable Action	CONTROL pin action when commanding the unit to turn off.	0	Soft Off	Use the programmed turn off delay and fall time.

BMR492 series DC-DC Converters Input
 40 - 60 V, Output up to 42 A / 504 W

28701-BMR49203 03 revB May 2021

© Flex

Bit	Function	Description	Value	Function	Description
			1	Imm. Off	Turn off the output and stop transferring energy to the output as fast as possible. The device's product literature shall specify whether or not the device sinks current to decrease the output voltage fall time.

CLEAR_FAULTS (0x03)

Description: Clears all fault status bits

WRITE_PROTECT (0x10)

Description: The WRITE_PROTECT command is used to control writing to the PMBus device. The intent of this command is to provide protection against accidental changes. This command is not intended to provide protection against deliberate or malicious changes to a device's configuration or operation.

Bit	Description	Value	Function	Description
7:0	All supported commands may have their parameters read, regardless of the WRITE_PROTECT settings.	0x80	Disable all writes	Disable all writes except to the WRITE_PROTECT command.
		0x40	Enable operation	Disable all writes except to the WRITE_PROTECT, OPERATION and PAGE commands.
		0x20	Enable control and Vout commands	Disable all writes except to the WRITE_PROTECT, OPERATION, PAGE, ON_OFF_CONFIG and VOUT_COMMAND commands.
		0x00	Enable all commands	Enable writes to all commands.

STORE_DEFAULT_ALL (0x11)

Description: Commands the device to store its configuration into the Default Store.

RESTORE_DEFAULT_ALL (0x12)

Description: Commands the device to restore its configuration from the Default Store.

STORE_USER_ALL (0x15)

Description: Stores, at the USER level, all PMBus values that were changed since the last restore command.

RESTORE_USER_ALL (0x16)

Description: Restores PMBus settings that were stored using STORE_USER_ALL. This command is automatically performed at power up.

BMR492 series DC-DC Converters Input
 40 - 60 V, Output up to 42 A / 504 W

28701-BMR49203 03 revB May 2021

© Flex

CAPABILITY (0x19)

Description: This command provides a way for a host system to determine some key capabilities of a PMBus device.

Bit	Function	Description	Value	Function	Description
7	Packet Error Checking	Packet error checking.	00	Not supported	Packet Error Checking not supported.
			01	Supported	Packet Error Checking is supported.
6:5	Maximum Bus Speed	Maximum bus speed.	00	100kHz	Maximum supported bus speed is 100 kHz.
			01	400kHz	Maximum supported bus speed is 400 kHz.
3:0	Smbalert	SMBALERT	00	No Smbalert	The device does not have a SMBALERT# pin and does not support the SMBus Alert Response protocol.
			01	Have Smbalert	The device does have a SMBALERT# pin and does support the SMBus Alert Response protocol.

SMBALERT_MASK (0x1B)

Status Registers: STATUS_VOUT (0x7A), STATUS_IOUT (0x7B), STATUS_INPUT (0x7C), STATUS_TEMPERATURE (0x7D), STATUS_CML (0x7E), STATUS_MFR_SPECIFIC (0x80)

Description: The SMBALERT_MASK command may be used to prevent a warning or fault condition from asserting the SALERT output signal. The format used is to pass the command code for the status register which would indicate the fault intended to be masked, along with bit or bits in the status register which would be set in the case of a fault.

Bit	Function	Description	Value	Function	Description
7	Mask Bit 7		0	Pull SALERT	
			1	Ignore	
6	Mask Bit 6		0	Pull SALERT	
			1	Ignore	
5	Mask Bit 5		0	Pull SALERT	
			1	Ignore	
4	Mask Bit 4		0	Pull SALERT	
			1	Ignore	
3	Mask Bit 3		0	Pull SALERT	
			1	Ignore	
2	Mask Bit 2		0	Pull SALERT	
			1	Ignore	
1	Mask Bit 1		0	Pull SALERT	
			1	Ignore	
0	Mask Bit 0		0	Pull SALERT	
			1	Ignore	

BMR492 series DC-DC Converters Input
 40 - 60 V, Output up to 42 A / 504 W

28701-BMR49203 03 revB May 2021

© Flex

VOUT_MODE (0x20)

Description: Controls how future VOUT-related commands parameters will be interpreted.

Bit	Function	Description	Format
4:0		Five bit two's complement EXPONENT for the MANTISSA delivered as the data bytes for VOUT_COMMAND in VOUT_LINEAR Mode, five bit VID code identifier per in VID Mode or always set to 00000b in Direct Mode.	Integer Signed

Bit	Function	Description	Value	Function	Description
7:5		Set to 000b to select VOUT_LINEAR Mode (Five bit two's complement exponent for the MANTISSA delivered as the data bytes for an output voltage related command), set to 001b to select VID Mode (Five bit VID code identifier per) or set to 010b to select Direct Mode (Always set to 00000b).	000	Linear	Linear Mode Format.
			001	VID	VID Mode.
			010	Direct	Direct Mode.

VOUT_COMMAND (0x21)

Description: Commands the device to transition to a new output voltage.

Bit	Description	Format	Unit
15:0	Sets the nominal value of the output voltage.	Vout Mode Unsigned	V

VOUT_TRIM (0x22)

Description: Configures a fixed offset to be applied to the output voltage when enabled.

Bit	Description	Format	Unit
15:0	Sets VOUT trim value. The two bytes are formatted as a two's complement binary mantissa, used in conjunction with the exponent set in VOUT_MODE.	Vout Mode Signed	V

VOUT_CAL_OFFSET (0x23)

Description: Vout calibration value. It is a signed number in Vout linear mode. The setting will be applied output voltage.

Bit	Description	Format	Unit
15:0	Vout calibration value. It is a signed number in Vout linear mode. The setting will be applied output voltage.	Vout Mode Signed	V

VOUT_MAX (0x24)

Description: Configures the maximum allowed output voltage.

Bit	Description	Format	Unit
15:0	Sets the maximum possible value setting of VOUT. The maximum VOUT_MAX setting is 110% of the pin-strap setting.	Vout Mode Unsigned	V

VOUT_MARGIN_HIGH (0x25)

Description: Configures the target for margin-up commands.

Bit	Description	Format	Unit
15:0	Sets the value of the VOUT during a margin high.	Vout Mode Unsigned	V

BMR492 series DC-DC Converters Input
 40 - 60 V, Output up to 42 A / 504 W

28701-BMR49203 03 revB May 2021

© Flex

VOUT_MARGIN_LOW (0x26)

Description: Configures the target for margin-down commands.

Bit	Description	Format	Unit
15:0	Sets the value of the VOUT during a margin low.	Vout Mode Unsigned	V

VOUT_TRANSITION_RATE (0x27)

Description: Configures the transition time for margins and VCOMMAND output changes.

Bit	Description	Format	Unit
15:0	Sets the transition rate during margin or other change of VOUT.	Linear	V/ms

VOUT_DROOP (0x28)

Description: Configures the Isense voltage to load current ratio.

Bit	Description	Format	Unit
15:0	Sets the effective load line (V/I slope) for the rail in which the device is used.	Linear	mV/A

VOUT_MIN (0x2B)

Description: This command is used to limit the minimum output voltage, irrespective of whatever voltage is commanded by a combination of VOUT_COMMAND (or VOUT_MARGIN_HIGH or VOUT_MARGIN_LOW) and VOUT_TRIM. The intent of this command is to provide a safeguard against a user accidentally setting the output voltage to a possibly destructive level rather than to be the primary output overprotection. The exponent is set by VOUT_MODE. If an attempt is made to program the output voltage lower than the limit set by this command, this will flag a WARNING condition, but NOT a fault.

Bit	Description	Format	Unit
15:0	This command is used to limit the minimum output voltage	Vout Mode Unsigned	V

MAX_DUTY (0x32)

Description: Configures the maximum allowed duty-cycle.

Bit	Description	Format	Unit
15:0	Sets the maximum allowable duty cycle of the switching frequency.	Linear	%

FREQUENCY_SWITCH (0x33)

Description: Controls the switching frequency in 1kHz steps.

Bit	Description	Format	Unit
15:0	Sets the switching frequency.	Linear	kHz

VIN_ON (0x35)

Description: The VIN_ON command sets the value of the input voltage, in volts, at which the unit should start power conversion.

Bit	Description	Format	Unit
15:0	Sets the VIN ON threshold.	Linear	V

VIN_OFF (0x36)

Description: The VIN_OFF command sets the value of the input voltage, in volts, at which the unit, once operation has started, should stop power conversion.

Bit	Description	Format	Unit
15:0	Sets the VIN OFF threshold.	Linear	V

BMR492 series DC-DC Converters Input
 40 - 60 V, Output up to 42 A / 504 W

28701-BMR49203 03 revB May 2021

© Flex

INTERLEAVE (0x37)

Description: Configures the phase offset with respect to a common SYNC clock. When multiple product share a common DC input supply, spreading of the switching phases between the products can be utilized. This reduces the input capacitance requirements and efficiency losses, since the peak current drawn from the input supply is effectively spread out over the whole switch period. If two or more units have their outputs connected in parallel, interleaving will reduce ripple currents. This requires that the products are synchronized using the SYNC pin.

Bit	Function	Description	Format
11:8	Group ID Number	Value 0-15. Sets an ID number to a group of interleaved rails.	Integer Unsigned
7:4	Number of Rails	Value 0-15. Sets the number of units in the group, including the SYNC OUT product.	Integer Unsigned
3:0	Rail Position	Value 0-15. Sets the interleave order for this unit. The product configured to SYNC OUT shall be assigned to number 0	Integer Unsigned

IOUT_CAL_OFFSET (0x39)

Description: Sets the current-sense offset.

Bit	Description	Format	Unit
15:0	Sets an offset to IOUT readings. Use to compensate for delayed measurements of current ramp.	Linear	A

VOUT_OV_FAULT_LIMIT (0x40)

Description: Output over voltage fault limit.

Bit	Description	Format	Unit
15:0	Output over voltage fault limit.	Vout Mode Unsigned	V

VOUT_OV_FAULT_RESPONSE (0x41)

Description: Output over voltage fault response.

Bit	Function	Description	Value	Function	Description
7:6	Response		00	Ignore Fault	The PMBus device continues operation without interruption.
			01	Perform Retries while Operating	The PMBus device continues operation for the delay time specified by bits [2:0] and the delay time unit specified for that particular fault. If the fault condition is still present at the end of the delay time, the unit responds as programmed in the Retry Setting (bits [5:3]).
			10	Disable and retry	The device shuts down (disables the output) and responds according to the retry setting in bits [5:3].

BMR492 series DC-DC Converters Input
 40 - 60 V, Output up to 42 A / 504 W

28701-BMR49203 03 revB May 2021

© Flex

Bit	Function	Description	Value	Function	Description
		Describes the device interruption operation. 00b - The PMBus device continues operation without interruption. 01b - The PMBus device continues operation for the delay time specified by bits [2:0] and the delay time unit specified for that particular fault. If the fault condition condition is still present at the end of the delay time, the unit responds as programmed in the Retry Setting (bits [5:3]). 10b - The device shuts down (disables the output) and responds according to the Retry Setting in bits [5:3]. 11b - The device's output is disabled while the fault is present. Operation resumes and the output is enabled when the fault condition no longer exists.	11	Disable until Fault Cleared	A fault can cleared in several ways: The bit is individually cleared, The device receives a CLEAR_FAULTS command, a RESET signal (if one exists) is asserted, the output is commanded through the CTRL pin, the OPERATION command, or the combined action of the CTRL pin and OPERATION command, to turn off and then to turn back on, or Bias power is removed from the PMBus device.
5:3	Retries	The device attempts to restart the number of times set by these bits. 000b means the device does not attempt a restart. 111b means the device attempts restarting continuously.	000	Do Not Retry	A zero value for the Retry Setting means that the unit does not attempt to restart. The output remains disabled until the fault is cleared (Section 10.7).
			001	Retry Once	The PMBus device attempts to restart 1 time. If the device fails to restart, it disables the output and remains off until the fault is cleared as described in Section 10.7. The time between the start of each attempt to restart is set by the value in bits [2:] along with the delay time unit specified for that particular fault.
			010	Retry Twice	The PMBus device attempts to restart 2 times. If the device fails to restart, it disables the output and remains off until the fault is cleared as described in Section 10.7. The time between the start of each attempt to restart is set by the value in bits [2:] along with the delay time unit specified for that particular fault.
			011	Retry 3 times	The PMBus device attempts to restart 3 times. If the device fails to restart, it disables the output and remains off until the fault is cleared as described in Section 10.7. The time between the start of each attempt to restart is set by the value in bits [2:] along with the delay time unit specified for that particular fault.

BMR492 series DC-DC Converters Input
40 - 60 V, Output up to 42 A / 504 W

28701-BMR49203 03 revB May 2021

© Flex

Bit	Function	Description	Value	Function	Description
			100	Retry 4 times	The PMBus device attempts to restart 4 times. If the device fails to restart, it disables the output and remains off until the fault is cleared as described in Section 10.7. The time between the start of each attempt to restart is set by the value in bits [2:] along with the delay time unit specified for that particular fault.
			101	Retry 5 times	The PMBus device attempts to restart 5 times. If the device fails to restart, it disables the output and remains off until the fault is cleared as described in Section 10.7. The time between the start of each attempt to restart is set by the value in bits [2:] along with the delay time unit specified for that particular fault.
			110	Retry 6 times	The PMBus device attempts to restart 6 times. If the device fails to restart, it disables the output and remains off until the fault is cleared as described in Section 10.7. The time between the start of each attempt to restart is set by the value in bits [2:] along with the delay time unit specified for that particular fault.
			111	Retry Continuously	The PMBus device attempts to restart continuously, without limitation, until it is commanded OFF (by the CONTROL pin or OPERATION command or both), bias power is removed, or another fault condition causes the unit to shut down.
2:0	Retry Time and Delay Time	Number of delay time units. Used for either the amount of time the device is to continue operating after a fault is detected or for the amount of time between attempts to restart. The time unit is set in register 0xD2.	0	1	
			1	2	
			2	4	
			3	8	
			4	16	
			5	32	
			6	64	
			7	128	

VOUT_OV_WARN_LIMIT (0x42)

Description: Output over voltage warning limit.

Bit	Description	Format	Unit
15:0	Output over voltage warning limit.	Vout Mode Unsigned	V

VOUT_UV_WARN_LIMIT (0x43)

Description: Output under voltage warning limit.

Bit	Description	Format	Unit
15:0	Output under voltage warning limit.	Vout Mode Unsigned	V

BMR492 series DC-DC Converters Input
40 - 60 V, Output up to 42 A / 504 W

28701-BMR49203 03 revB May 2021

© Flex

VOUT_UV_FAULT_LIMIT (0x44)

Description: Output under voltage fault limit.

Bit	Description	Format	Unit
15:0	Output under voltage fault limit.	Vout Mode Unsigned	V

BMR492 series DC-DC Converters Input
 40 - 60 V, Output up to 42 A / 504 W

28701-BMR49203 03 revB May 2021

© Flex

VOUT_UV_FAULT_RESPONSE (0x45)

Description: Output under voltage fault response.

Bit	Function	Description	Value	Function	Description
7:6	Response	Describes the device interruption operation. 00b - The PMBus device continues operation without interruption. 01b - The PMBus device continues operation for the delay time specified by bits [2:0] and the delay time unit specified for that particular fault. If the fault condition is still present at the end of the delay time, the unit responds as programmed in the Retry Setting (bits [5:3]). 10b - The device shuts down (disables the output) and responds according to the Retry Setting in bits [5:3]. 11b - The device's output is disabled while the fault is present. Operation resumes and the output is enabled when the fault condition no longer exists.	00	Ignore Fault	The PMBus device continues operation without interruption.
			01	Perform Retries while Operating	The PMBus device continues operation for the delay time specified by bits [2:0] and the delay time unit specified for that particular fault. If the fault condition is still present at the end of the delay time, the unit responds as programmed in the Retry Setting (bits [5:3]).
			10	Disable and retry	The device shuts down (disables the output) and responds according to the retry setting in bits [5:3].
			11	Disable until Fault Cleared	A fault can be cleared in several ways: The bit is individually cleared, The device receives a CLEAR_FAULTS command, a RESET signal (if one exists) is asserted, the output is commanded through the CTRL pin, the OPERATION command, or the combined action of the CTRL pin and OPERATION command, to turn off and then to turn back on, or Bias power is removed from the PMBus device.
5:3	Retries	The device attempts to restart the number of times set by these bits. 000b means the device does not attempt a restart. 111b means the device attempts restarting continuously.	000	Do Not Retry	A zero value for the Retry Setting means that the unit does not attempt to restart. The output remains disabled until the fault is cleared (Section 10.7).
			001	Retry Once	The PMBus device attempts to restart 1 time. If the device fails to restart, it disables the output and remains off until the fault is cleared as described in Section 10.7. The time between the start of each attempt to restart is set by the value in bits [2:] along with the delay time unit specified for that particular fault.
			010	Retry Twice	The PMBus device attempts to restart 2 times. If the device fails to restart, it disables the output and remains off until the fault is cleared as described in Section 10.7. The time between the start of each attempt to restart is set by the value in bits [2:] along with the delay time unit specified for that particular fault.

BMR492 series DC-DC Converters Input
40 - 60 V, Output up to 42 A / 504 W

28701-BMR49203 03 revB May 2021

© Flex

Bit	Function	Description	Value	Function	Description
			011	Retry 3 times	The PMBus device attempts to restart 3 times. If the device fails to restart, it disables the output and remains off until the fault is cleared as described in Section 10.7. The time between the start of each attempt to restart is set by the value in bits [2:] along with the delay time unit specified for that particular fault.
			100	Retry 4 times	The PMBus device attempts to restart 4 times. If the device fails to restart, it disables the output and remains off until the fault is cleared as described in Section 10.7. The time between the start of each attempt to restart is set by the value in bits [2:] along with the delay time unit specified for that particular fault.
			101	Retry 5 times	The PMBus device attempts to restart 5 times. If the device fails to restart, it disables the output and remains off until the fault is cleared as described in Section 10.7. The time between the start of each attempt to restart is set by the value in bits [2:] along with the delay time unit specified for that particular fault.
			110	Retry 6 times	The PMBus device attempts to restart 6 times. If the device fails to restart, it disables the output and remains off until the fault is cleared as described in Section 10.7. The time between the start of each attempt to restart is set by the value in bits [2:] along with the delay time unit specified for that particular fault.
			111	Retry Continuously	The PMBus device attempts to restart continuously, without limitation, until it is commanded OFF (by the CONTROL pin or OPERATION command or both), bias power is removed, or another fault condition causes the unit to shut down.
2:0	Retry Time and Delay Time	Number of delay time units. Used for either the amount of time the device is to continue operating after a fault is detected or for the amount of time between attempts to restart. The time unit is set in register 0xD2.	0	1	
			1	2	
			2	4	
			3	8	
			4	16	
			5	32	
			6	64	
			7	128	

BMR492 series DC-DC Converters Input
 40 - 60 V, Output up to 42 A / 504 W

28701-BMR49203 03 revB May 2021

© Flex

IOUT_OC_FAULT_LIMIT (0x46)

Description: Output over current limit.

Bit	Description	Format	Unit
15:0	Output over current fault limit.	Linear	A

IOUT_OC_FAULT_RESPONSE (0x47)

Description: Output over current fault response.

Bit	Function	Description	Value	Function	Description
7:6	Response	For all values of bits [7:6], the device: Sets the corresponding fault bit in the status registers and If the device supports notifying the host, it does so.	00	Ignore Fault	The PMBus device continues to operate indefinitely while maintaining the output current at the value set by IOUT_OC_FAULT_LIMIT without regard to the output voltage (known as constant-current or brickwall limiting).
			01	Conditioned constant current	The PMBus device continues to operate indefinitely while maintaining the output current at the value set by IOUT_OC_FAULT_LIMIT as long as the output voltage remains above the minimum value specified by IOUT_OC_LV_FAULT_LIMIT. If the output voltage is pulled down to less than that value, then the PMBus device shuts down and responds according to the Retry setting in bits [5:3].
			10	Delay w/ Const. Current & Retry	The PMBus device continues to operate, maintaining the output current at the value set by IOUT_OC_FAULT_LIMIT without regard to the output voltage, for the delay time set by bits [2:0] and the delay time units for specified in the IOUT_OC_FAULT_RESPONSE. If the device is still operating in current limiting at the end of the delay time, the device responds as programmed by the Retry Setting in bits [5:3].
			11	Disable and Retry	The PMBus device shuts down and responds as programmed by the Retry Setting in bits [5:3].
5:3	Retries		000	Do Not Retry	A zero value for the Retry Setting means that the unit does not attempt to restart. The output remains disabled until the fault is cleared (Section 10.7).

BMR492 series DC-DC Converters Input
 40 - 60 V, Output up to 42 A / 504 W

28701-BMR49203 03 revB May 2021

© Flex

Bit	Function	Description	Value	Function	Description
		The device attempts to restart the number of times set by these bits. 000b means the device does not attempt a restart. 111b means the device attempts restarting continuously.	001	Retry Once	The PMBus device attempts to restart 1 time. If the device fails to restart, it disables the output and remains off until the fault is cleared as described in Section 10.7. The time between the start of each attempt to restart is set by the value in bits [2:] along with the delay time unit specified for that particular fault.
			010	Retry Twice	The PMBus device attempts to restart 2 times. If the device fails to restart, it disables the output and remains off until the fault is cleared as described in Section 10.7. The time between the start of each attempt to restart is set by the value in bits [2:] along with the delay time unit specified for that particular fault.
			011	Retry 3 times	The PMBus device attempts to restart 3 times. If the device fails to restart, it disables the output and remains off until the fault is cleared as described in Section 10.7. The time between the start of each attempt to restart is set by the value in bits [2:] along with the delay time unit specified for that particular fault.
			100	Retry 4 times	The PMBus device attempts to restart 4 times. If the device fails to restart, it disables the output and remains off until the fault is cleared as described in Section 10.7. The time between the start of each attempt to restart is set by the value in bits [2:] along with the delay time unit specified for that particular fault.
			101	Retry 5 times	The PMBus device attempts to restart 5 times. If the device fails to restart, it disables the output and remains off until the fault is cleared as described in Section 10.7. The time between the start of each attempt to restart is set by the value in bits [2:] along with the delay time unit specified for that particular fault.
			110	Retry 6 times	The PMBus device attempts to restart 6 times. If the device fails to restart, it disables the output and remains off until the fault is cleared as described in Section 10.7. The time between the start of each attempt to restart is set by the value in bits [2:] along with the delay time unit specified for that particular fault.

BMR492 series DC-DC Converters Input
 40 - 60 V, Output up to 42 A / 504 W

28701-BMR49203 03 revB May 2021

© Flex

Bit	Function	Description	Value	Function	Description
			111	Retry Continuously	The PMBus device attempts to restart continuously, without limitation, until it is commanded OFF (by the CONTROL pin or OPERATION command or both), bias power is removed, or another fault condition causes the unit to shut down.
2:0	Retry Time and Delay Time	Number of delay time units. Used for either the amount of time the device is to continue operating after a fault is detected or for the amount of time between attempts to restart. The time unit is set in register 0xD2.	0	1	
			1	2	
			2	4	
			3	8	
			4	16	
			5	32	
			6	64	
			7	128	

IOUT_OC_LV_FAULT_LIMIT (0x48)

Description: Set the output over-current low-voltage fault threshold.

Bit	Description	Format	Unit
15:0	Set the output over-current low-voltage fault threshold.	Vout Mode Unsigned	V

IOUT_OC_WARN_LIMIT (0x4A)

Description: Output over current warning limit.

Bit	Description	Format	Unit
15:0	Output over current warning limit.	Linear	A

IOUT_UC_FAULT_LIMIT (0x4B)

Description: Sets the output under-current peak limit.

Bit	Description	Format	Unit
15:0	Sets the IOUT under-current peak fault threshold.	Linear	A

BMR492 series DC-DC Converters Input
40 - 60 V, Output up to 42 A / 504 W

28701-BMR49203 03 revB May 2021

© Flex

IOU_T_UC_FAULT_RESPONSE (0x4C)

Description: Configures the output undercurrent fault response. The command format is the same as the PMBus standard responses for voltage and temperature faults except that it sets the undercurrent status bit.

Bit	Function	Description	Value	Function	Description
7:6	Response	Describes the device interruption operation. For all modes set by bits [7:6], the device pulls SALERT low and sets the related fault bit in the status registers.	00	Ignore Fault	The PMBus device continues operation without interruption.
			01	Perform Retries while Operating	The PMBus device continues operation for the delay time specified by bits [2:0] and the delay time unit specified for that particular fault. If the fault condition is still present at the end of the delay time, the unit responds as programmed in the Retry Setting (bits [5:3]).
			10	Disable and Retry	The device shuts down (disables the output) and responds according to the retry setting in bits [5:3].
			11	Disable until clear	The device's output is disabled while the fault is present. Operation resumes and the output is enabled when the fault condition no longer exists.
5:3	Retry Setting	The device attempts to restart the number of times set by these bits.	000	Do Not Retry	A zero value for the Retry Setting means that the unit does not attempt to restart. The output remains disabled until the fault is cleared.
			001	Retry Once	The PMBus device attempts to restart 1 time. If the device fails to restart, it disables the output and remains off until the fault is cleared. The time between the start of each attempt to restart is set by the value in bits [2:0] along with the delay time unit specified for that particular fault.
			010	Retry Twice	The PMBus device attempts to restart 2 times.
			011	Retry 3 times	The PMBus device attempts to restart 3 times.
			100	Retry 4 times	The PMBus device attempts to restart 4 times.
			101	Retry 5 times	The PMBus device attempts to restart 5 times.
			110	Retry 6 times	The PMBus device attempts to restart 6 times.
			111	Retry Continuously	The PMBus device attempts to restart continuously, without limitation, until output is DISABLED, bias power is removed, or another fault condition causes the output to shut down.
2:0	Retry Time and Delay Time	Number of delay time units. Used for either the amount of time the device (10 ms/unit) is to continue operating after a fault is detected or for the amount of time (8.2 ms/unit) between attempts to restart.	0	0	
			1	1	
			2	2	
			3	3	
			4	4	
			5	5	
			6	6	

BMR492 series DC-DC Converters Input
 40 - 60 V, Output up to 42 A / 504 W

28701-BMR49203 03 revB May 2021

© Flex

Bit	Function	Description	Value	Function	Description
			7	7	

OT_FAULT_LIMIT (0x4F)

Description: Over temperature fault limit.

Bit	Description	Format	Unit
15:0	Over temperature fault limit.	Linear	°C

OT_FAULT_RESPONSE (0x50)

Description: Over temperature fault response.

Bit	Function	Description	Value	Function	Description
7:6	Response		00	Ignore Fault	The PMBus device continues operation without interruption.
			01	Perform Retries while Operating	The PMBus device continues operation for the delay time specified by bits [2:0] and the delay time unit specified for that particular fault. If the fault condition is still present at the end of the delay time, the unit responds as programmed in the Retry Setting (bits [5:3]).
			10	Disable and retry	The device shuts down (disables the output) and responds according to the retry setting in bits [5:3].
			11	Disable until Fault Cleared	A fault can be cleared in several ways: The bit is individually cleared, The device receives a CLEAR_FAULTS command, a RESET signal (if one exists) is asserted, the output is commanded through the CTRL pin, the OPERATION command, or the combined action of the CTRL pin and OPERATION command, to turn off and then to turn back on, or Bias power is removed from the PMBus device.
5:3	Retries		000	Do Not Retry	A zero value for the Retry Setting means that the unit does not attempt to restart. The output remains disabled until the fault is cleared (Section 10.7).
			001	Retry Once	The PMBus device attempts to restart 1 time. If the device fails to restart, it disables the output and remains off until the fault is cleared as described in Section 10.7. The time between the start of each attempt to restart is set by the value in bits [2:] along with the delay time unit specified for that particular fault.

BMR492 series DC-DC Converters Input
40 - 60 V, Output up to 42 A / 504 W

28701-BMR49203 03 revB May 2021

© Flex

Bit	Function	Description	Value	Function	Description
			010	Retry Twice	The PMBus device attempts to restart 2 times. If the device fails to restart, it disables the output and remains off until the fault is cleared as described in Section 10.7. The time between the start of each attempt to restart is set by the value in bits [2:] along with the delay time unit specified for that particular fault.
			011	Retry 3 times	The PMBus device attempts to restart 3 times. If the device fails to restart, it disables the output and remains off until the fault is cleared as described in Section 10.7. The time between the start of each attempt to restart is set by the value in bits [2:] along with the delay time unit specified for that particular fault.
			100	Retry 4 times	The PMBus device attempts to restart 4 times. If the device fails to restart, it disables the output and remains off until the fault is cleared as described in Section 10.7. The time between the start of each attempt to restart is set by the value in bits [2:] along with the delay time unit specified for that particular fault.
			101	Retry 5 times	The PMBus device attempts to restart 5 times. If the device fails to restart, it disables the output and remains off until the fault is cleared as described in Section 10.7. The time between the start of each attempt to restart is set by the value in bits [2:] along with the delay time unit specified for that particular fault.
			110	Retry 6 times	The PMBus device attempts to restart 6 times. If the device fails to restart, it disables the output and remains off until the fault is cleared as described in Section 10.7. The time between the start of each attempt to restart is set by the value in bits [2:] along with the delay time unit specified for that particular fault.
			111	Retry Continuously	The PMBus device attempts to restart continuously, without limitation, until it is commanded OFF (by the CONTROL pin or OPERATION command or both), bias power is removed, or another fault condition causes the unit to shut down.
			2:0	Retry Time and Delay Time	
			1	2	
			2	4	
			3	8	

BMR492 series DC-DC Converters Input
 40 - 60 V, Output up to 42 A / 504 W

28701-BMR49203 03 revB May 2021

© Flex

Bit	Function	Description	Value	Function	Description
		Number of delay time units. Used for either the amount of time the device is to continue operating after a fault is detected or for the amount of time between attempts to restart. The time unit is set in register 0xD2.	4	16	
			5	32	
			6	64	
			7	128	

OT_WARN_LIMIT (0x51)

Description: Over temperature warning limit.

Bit	Description	Format	Unit
15:0	Over temperature warning limit.	Linear	°C

UT_WARN_LIMIT (0x52)

Description: Under temperature warning limit.

Bit	Description	Format	Unit
15:0	Under temperature warning limit.	Linear	°C

UT_FAULT_LIMIT (0x53)

Description: Under temperature fault limit.

Bit	Description	Format	Unit
15:0	Under temperature fault limit.	Linear	°C

UT_FAULT_RESPONSE (0x54)

Description: Under temperature fault response.

Bit	Function	Description	Value	Function	Description
7:6	Response		00	Ignore Fault	The PMBus device continues operation without interruption.
			01	Perform Retries while Operating	The PMBus device continues operation for the delay time specified by bits [2:0] and the delay time unit specified for that particular fault. If the fault condition is still present at the end of the delay time, the unit responds as programmed in the Retry Setting (bits [5:3]).
			10	Disable and retry	The device shuts down (disables the output) and responds according to the retry setting in bits [5:3].
			11	Disable until Fault Cleared	A fault can cleared in several ways: The bit is individually cleared, The device receives a CLEAR_FAULTS command, a RESET signal (if one exists) is asserted, the output is commanded through the CTRL pin, the OPERATION command, or the combined action of the CTRL pin and OPERATION command, to turn off and then to turn back on, or Bias power is removed from the PMBus device.

BMR492 series DC-DC Converters Input
40 - 60 V, Output up to 42 A / 504 W

28701-BMR49203 03 revB May 2021

© Flex

Bit	Function	Description	Value	Function	Description
5:3	Retries		000	Do Not Retry	A zero value for the Retry Setting means that the unit does not attempt to restart. The output remains disabled until the fault is cleared (Section 10.7).
			001	Retry Once	The PMBus device attempts to restart 1 time. If the device fails to restart, it disables the output and remains off until the fault is cleared as described in Section 10.7. The time between the start of each attempt to restart is set by the value in bits [2:] along with the delay time unit specified for that particular fault.
			010	Retry Twice	The PMBus device attempts to restart 2 times. If the device fails to restart, it disables the output and remains off until the fault is cleared as described in Section 10.7. The time between the start of each attempt to restart is set by the value in bits [2:] along with the delay time unit specified for that particular fault.
			011	Retry 3 times	The PMBus device attempts to restart 3 times. If the device fails to restart, it disables the output and remains off until the fault is cleared as described in Section 10.7. The time between the start of each attempt to restart is set by the value in bits [2:] along with the delay time unit specified for that particular fault.
			100	Retry 4 times	The PMBus device attempts to restart 4 times. If the device fails to restart, it disables the output and remains off until the fault is cleared as described in Section 10.7. The time between the start of each attempt to restart is set by the value in bits [2:] along with the delay time unit specified for that particular fault.
			101	Retry 5 times	The PMBus device attempts to restart 5 times. If the device fails to restart, it disables the output and remains off until the fault is cleared as described in Section 10.7. The time between the start of each attempt to restart is set by the value in bits [2:] along with the delay time unit specified for that particular fault.

BMR492 series DC-DC Converters Input
40 - 60 V, Output up to 42 A / 504 W

28701-BMR49203 03 revB May 2021

© Flex

Bit	Function	Description	Value	Function	Description
			110	Retry 6 times	The PMBus device attempts to restart 6 times. If the device fails to restart, it disables the output and remains off until the fault is cleared as described in Section 10.7. The time between the start of each attempt to restart is set by the value in bits [2:] along with the delay time unit specified for that particular fault.
			111	Retry Continuously	The PMBus device attempts to restart continuously, without limitation, until it is commanded OFF (by the CONTROL pin or OPERATION command or both), bias power is removed, or another fault condition causes the unit to shut down.
2:0	Retry Time and Delay Time	Number of delay time units. Used for either the amount of time the device is to continue operating after a fault is detected or for the amount of time between attempts to restart. The time unit is set in register 0xD2.	0	1	
			1	2	
			2	4	
			3	8	
			4	16	
			5	32	
			6	64	
			7	128	

VIN_OV_FAULT_LIMIT (0x55)

Description: Input over voltage fault limit.

Bit	Description	Format	Unit
15:0	Input over voltage fault limit.	Linear	V

VIN_OV_FAULT_RESPONSE (0x56)

Description: Input over voltage fault response.

Bit	Function	Description	Value	Function	Description
7:6	Response		00	Ignore Fault	The PMBus device continues operation without interruption.
			01	Perform Retries while Operating	The PMBus device continues operation for the delay time specified by bits [2:0] and the delay time unit specified for that particular fault. If the fault condition is still present at the end of the delay time, the unit responds as programmed in the Retry Setting (bits [5:3]).
			10	Disable and retry	The device shuts down (disables the output) and responds according to the retry setting in bits [5:3].

BMR492 series DC-DC Converters Input
 40 - 60 V, Output up to 42 A / 504 W

28701-BMR49203 03 revB May 2021

© Flex

Bit	Function	Description	Value	Function	Description
			11	Disable until Fault Cleared	A fault can be cleared in several ways: The bit is individually cleared, The device receives a CLEAR_FAULTS command, a RESET signal (if one exists) is asserted, the output is commanded through the CTRL pin, the OPERATION command, or the combined action of the CTRL pin and OPERATION command, to turn off and then to turn back on, or Bias power is removed from the PMBus device.
5:3	Retries		000	Do Not Retry	A zero value for the Retry Setting means that the unit does not attempt to restart. The output remains disabled until the fault is cleared (Section 10.7).
			001	Retry Once	The PMBus device attempts to restart 1 time. If the device fails to restart, it disables the output and remains off until the fault is cleared as described in Section 10.7. The time between the start of each attempt to restart is set by the value in bits [2:] along with the delay time unit specified for that particular fault.
			010	Retry Twice	The PMBus device attempts to restart 2 times. If the device fails to restart, it disables the output and remains off until the fault is cleared as described in Section 10.7. The time between the start of each attempt to restart is set by the value in bits [2:] along with the delay time unit specified for that particular fault.
			011	Retry 3 times	The PMBus device attempts to restart 3 times. If the device fails to restart, it disables the output and remains off until the fault is cleared as described in Section 10.7. The time between the start of each attempt to restart is set by the value in bits [2:] along with the delay time unit specified for that particular fault.
			100	Retry 4 times	The PMBus device attempts to restart 4 times. If the device fails to restart, it disables the output and remains off until the fault is cleared as described in Section 10.7. The time between the start of each attempt to restart is set by the value in bits [2:] along with the delay time unit specified for that particular fault.

BMR492 series DC-DC Converters Input
 40 - 60 V, Output up to 42 A / 504 W

28701-BMR49203 03 revB May 2021

© Flex

Bit	Function	Description	Value	Function	Description
			101	Retry 5 times	The PMBus device attempts to restart 5 times. If the device fails to restart, it disables the output and remains off until the fault is cleared as described in Section 10.7. The time between the start of each attempt to restart is set by the value in bits [2:] along with the delay time unit specified for that particular fault.
			110	Retry 6 times	The PMBus device attempts to restart 6 times. If the device fails to restart, it disables the output and remains off until the fault is cleared as described in Section 10.7. The time between the start of each attempt to restart is set by the value in bits [2:] along with the delay time unit specified for that particular fault.
			111	Retry Continuously	The PMBus device attempts to restart continuously, without limitation, until it is commanded OFF (by the CONTROL pin or OPERATION command or both), bias power is removed, or another fault condition causes the unit to shut down.
2:0	Retry Time and Delay Time	Number of delay time units. Used for either the amount of time the device is to continue operating after a fault is detected or for the amount of time between attempts to restart. The time unit is set in register 0xD2.	0	1	
			1	2	
			2	4	
			3	8	
			4	16	
			5	32	
			6	64	
			7	128	

VIN_OV_WARN_LIMIT (0x57)

Description: Input over voltage warning limit.

Bit	Description	Format	Unit
15:0	Input over voltage warning limit.	Linear	V

VIN_UV_WARN_LIMIT (0x58)

Description: Input under voltage warning limit. This command set also the input voltage threshold for the HRR function (Hybrid Ratio Regulation). The HRR function is enabled with command MFR_SPECIAL_OPTIONS (0xE0).

Bit	Description	Format	Unit
15:0	Input under voltage warning limit and/or HRR threshold.	Linear	V

VIN_UV_FAULT_LIMIT (0x59)

Description: Input under voltage fault limit.

Bit	Description	Format	Unit
15:0	Input under voltage fault limit.	Linear	V

BMR492 series DC-DC Converters Input
40 - 60 V, Output up to 42 A / 504 W

28701-BMR49203 03 revB May 2021

© Flex

VIN_UV_FAULT_RESPONSE (0x5A)

Description: Input under voltage fault response.

Bit	Function	Description	Value	Function	Description
7:6	Response		00	Ignore Fault	The PMBus device continues operation without interruption.
			01	Perform Retries while Operating	The PMBus device continues operation for the delay time specified by bits [2:0] and the delay time unit specified for that particular fault. If the fault condition is still present at the end of the delay time, the unit responds as programmed in the Retry Setting (bits [5:3]).
			10	Disable and retry	The device shuts down (disables the output) and responds according to the retry setting in bits [5:3].
			11	Disable until Fault Cleared	A fault can be cleared in several ways: The bit is individually cleared, The device receives a CLEAR_FAULTS command, a RESET signal (if one exists) is asserted, the output is commanded through the CTRL pin, the OPERATION command, or the combined action of the CTRL pin and OPERATION command, to turn off and then to turn back on, or Bias power is removed from the PMBus device.
5:3	Retries		000	Do Not Retry	A zero value for the Retry Setting means that the unit does not attempt to restart. The output remains disabled until the fault is cleared (Section 10.7).
			001	Retry Once	The PMBus device attempts to restart 1 time. If the device fails to restart, it disables the output and remains off until the fault is cleared as described in Section 10.7. The time between the start of each attempt to restart is set by the value in bits [2:] along with the delay time unit specified for that particular fault.
			010	Retry Twice	The PMBus device attempts to restart 2 times. If the device fails to restart, it disables the output and remains off until the fault is cleared as described in Section 10.7. The time between the start of each attempt to restart is set by the value in bits [2:] along with the delay time unit specified for that particular fault.

BMR492 series DC-DC Converters Input
40 - 60 V, Output up to 42 A / 504 W

28701-BMR49203 03 revB May 2021

© Flex

Bit	Function	Description	Value	Function	Description
			011	Retry 3 times	The PMBus device attempts to restart 3 times. If the device fails to restart, it disables the output and remains off until the fault is cleared as described in Section 10.7. The time between the start of each attempt to restart is set by the value in bits [2:] along with the delay time unit specified for that particular fault.
			100	Retry 4 times	The PMBus device attempts to restart 4 times. If the device fails to restart, it disables the output and remains off until the fault is cleared as described in Section 10.7. The time between the start of each attempt to restart is set by the value in bits [2:] along with the delay time unit specified for that particular fault.
			101	Retry 5 times	The PMBus device attempts to restart 5 times. If the device fails to restart, it disables the output and remains off until the fault is cleared as described in Section 10.7. The time between the start of each attempt to restart is set by the value in bits [2:] along with the delay time unit specified for that particular fault.
			110	Retry 6 times	The PMBus device attempts to restart 6 times. If the device fails to restart, it disables the output and remains off until the fault is cleared as described in Section 10.7. The time between the start of each attempt to restart is set by the value in bits [2:] along with the delay time unit specified for that particular fault.
			111	Retry Continuously	The PMBus device attempts to restart continuously, without limitation, until it is commanded OFF (by the CONTROL pin or OPERATION command or both), bias power is removed, or another fault condition causes the unit to shut down.
2:0	Retry Time and Delay Time	Number of delay time units. Used for either the amount of time the device is to continue operating after a fault is detected or for the amount of time between attempts to restart. The time unit is set in register 0xD2.	0	1	
			1	2	
			2	4	
			3	8	
			4	16	
			5	32	
			6	64	
			7	128	

BMR492 series DC-DC Converters Input
 40 - 60 V, Output up to 42 A / 504 W

28701-BMR49203 03 revB May 2021

© Flex

POWER_GOOD_ON (0x5E)

Description: Sets the output voltage threshold for asserting PG (Power Good).

Bit	Description	Format	Unit
15:0	The POWER_GOOD_ON command sets the output voltage at which an optional POWER_GOOD signal should be asserted.	Vout Mode Unsigned	V

POWER_GOOD_OFF (0x5F)

Description: If the output voltage is lower than this one, negate power good if power good is enabled through MFR_MULTI_PIN_CONFIG and set the power good bit to 1 in PMBUS status.

Bit	Description	Format	Unit
15:0	If the output voltage is lower than this one, negate power good if power good is enabled through MFR_MULTI_PIN_CONFIG and set the power good bit to 1 in PMBUS status.	Vout Mode Unsigned	V

TON_DELAY (0x60)

Description: Sets the turn-on delay time

Bit	Description	Format	Unit
15:0	Sets the delay time from ENABLE to start of VOUT rise.	Linear	ms

TON_RISE (0x61)

Description: Sets the turn-on transition time.

Bit	Description	Format	Unit
15:0	Sets the rise time of VOUT after ENABLE and TON_DELAY.	Linear	ms

TON_MAX_FAULT_LIMIT (0x62)

Description: Sets an upper limit, in milliseconds, on how long the unit can attempt to power up the output without reaching the output undervoltage fault limit.

Bit	Description	Format	Unit
15:0	A value of 0 milliseconds means that there is no limit and that the unit can attempt to bring up the output voltage indefinitely.	Linear	ms

TON_MAX_FAULT_RESPONSE (0x63)

Description: Only some of the response types are supported.

Bit	Function	Description	Value	Function	Description
7:6	Response		00	Ignore Fault	The PMBus device continues operation without interruption.
			01	Perform Retries while Operating	The PMBus device continues operation for the delay time specified by bits [2:0] and the delay time unit specified for that particular fault. If the fault condition is still present at the end of the delay time, the unit responds as programmed in the Retry Setting (bits [5:3]).
			10	Disable and retry	The device shuts down (disables the output) and responds according to the retry setting in bits [5:3].

BMR492 series DC-DC Converters Input
40 - 60 V, Output up to 42 A / 504 W

28701-BMR49203 03 revB May 2021

© Flex

Bit	Function	Description	Value	Function	Description
			11	Disable until Fault Cleared	A fault can be cleared in several ways: The bit is individually cleared, The device receives a CLEAR_FAULTS command, a RESET signal (if one exists) is asserted, the output is commanded through the CTRL pin, the OPERATION command, or the combined action of the CTRL pin and OPERATION command, to turn off and then to turn back on, or Bias power is removed from the PMBus device.
5:3	Retries		000	Do Not Retry	A zero value for the Retry Setting means that the unit does not attempt to restart. The output remains disabled until the fault is cleared (Section 10.7).
			001	Retry Once	The PMBus device attempts to restart 1 time. If the device fails to restart, it disables the output and remains off until the fault is cleared as described in Section 10.7. The time between the start of each attempt to restart is set by the value in bits [2:] along with the delay time unit specified for that particular fault.
			010	Retry Twice	The PMBus device attempts to restart 2 times. If the device fails to restart, it disables the output and remains off until the fault is cleared as described in Section 10.7. The time between the start of each attempt to restart is set by the value in bits [2:] along with the delay time unit specified for that particular fault.
			011	Retry 3 times	The PMBus device attempts to restart 3 times. If the device fails to restart, it disables the output and remains off until the fault is cleared as described in Section 10.7. The time between the start of each attempt to restart is set by the value in bits [2:] along with the delay time unit specified for that particular fault.
			100	Retry 4 times	The PMBus device attempts to restart 4 times. If the device fails to restart, it disables the output and remains off until the fault is cleared as described in Section 10.7. The time between the start of each attempt to restart is set by the value in bits [2:] along with the delay time unit specified for that particular fault.

BMR492 series DC-DC Converters Input
 40 - 60 V, Output up to 42 A / 504 W

28701-BMR49203 03 revB May 2021

© Flex

Bit	Function	Description	Value	Function	Description
			101	Retry 5 times	The PMBus device attempts to restart 5 times. If the device fails to restart, it disables the output and remains off until the fault is cleared as described in Section 10.7. The time between the start of each attempt to restart is set by the value in bits [2:] along with the delay time unit specified for that particular fault.
			110	Retry 6 times	The PMBus device attempts to restart 6 times. If the device fails to restart, it disables the output and remains off until the fault is cleared as described in Section 10.7. The time between the start of each attempt to restart is set by the value in bits [2:] along with the delay time unit specified for that particular fault.
			111	Retry Continuously	The PMBus device attempts to restart continuously, without limitation, until it is commanded OFF (by the CONTROL pin or OPERATION command or both), bias power is removed, or another fault condition causes the unit to shut down.
2:0	Retry Time and Delay Time	Number of delay time units. Used for either the amount of time the device is to continue operating after a fault is detected or for the amount of time between attempts to restart. The time unit is set in register 0xD2. TON_MAX_FAULT_RESPONSE time unit is referenced to VOUT FAULT time unit.	0	1	
			1	2	
			2	4	
			3	8	
			4	16	
			5	32	
			6	64	
			7	128	

TOFF_DELAY (0x64)

Description: Sets the turn-off delay.

Bit	Description	Format	Unit
15:0	Sets the delay time from DISABLE to start of VOUT fall.	Linear	ms

TOFF_FALL (0x65)

Description: Sets the turn-off transition time.

Bit	Description	Format	Unit
15:0	Sets the fall time for VOUT after DISABLE and TOFF_DELAY.	Linear	ms

TOFF_MAX_WARN_LIMIT (0x66)

Description: Sets an upper limit, in milliseconds, on how long the unit can attempt to power down the output without reaching 12.5% of the output voltage programmed at the time the unit is turned off.

Bit	Description	Format	Unit
15:0		Linear	ms

BMR492 series DC-DC Converters Input
 40 - 60 V, Output up to 42 A / 504 W

28701-BMR49203 03 revB May 2021

© Flex

POUT_OP_WARN_LIMIT (0x6A)

Description: Sets the output over-power warning limit.

Bit	Description	Format	Unit
15:0	Sets the output over-power warning threshold.	Linear	W

PIN_OP_WARN_LIMIT (0x6B)

Description: Sets the input over-power warning limit.

Bit	Description	Format	Unit
15:0	Sets the input over-power warning threshold.	Linear	W

STATUS_BYTE (0x78)

Description: Returns a brief fault/warning status byte.

Bit	Function	Description	Value	Description
6	Off	This bit is asserted if the unit is not providing power to the output, regardless of the reason, including simply not being enabled.	0	No fault
			1	Fault
5	Vout Overvoltage Fault	An output overvoltage fault has occurred.	0	No fault
			1	Fault
4	Iout Overcurrent Fault	An output overcurrent fault has occurred.	0	No fault
			1	Fault
3	Vin Undervoltage Fault	An input undervoltage fault has occurred.	0	No fault
			1	Fault
2	Temperature	A temperature fault or warning has occurred.	0	No fault
			1	Fault
1	Communication/Logic	A communications, memory or logic fault has occurred.	0	No fault
			1	Fault
0	None of the Above	A fault or warning not listed in bits [7:1] has occurred.	0	No fault
			1	Fault

STATUS_WORD (0x79)

Description: Returns an extended fault/warning status byte.

Bit	Function	Description	Value	Description
15	Vout	An output voltage fault or warning has occurred.	0	No fault
			1	Fault
14	Iout/Pout	An output current or output power fault or warning has occurred.	0	No Fault.
			1	Fault.
13	Input	An input voltage, input current, or input power fault or warning has occurred.	0	No Fault.
			1	Fault.
11	Power-Good	The Power-Good signal, if present, is negated.	0	No Fault.
			1	Fault.
6	Off	This bit is asserted if the unit is not providing power to the output, regardless of the reason, including simply not being enabled.	0	No fault
			1	Fault
5	Vout Overvoltage Fault	An output overvoltage fault has occurred.	0	No Fault.
			1	Fault.
4	Iout Overcurrent Fault	An output overcurrent fault has occurred.	0	No Fault.
			1	Fault.
3	Vin Undervoltage Fault	An input undervoltage fault has occurred.	0	No Fault.
			1	Fault.
2	Temperature	A temperature fault or warning has occurred.	0	No Fault.
			1	Fault.
1	Communication/Logic	A communications, memory or logic fault has occurred.	0	No fault.
			1	Fault.
0	None of the Above	A fault or warning not listed in bits [7:1] has occurred.	0	No fault.
			1	Fault.

BMR492 series DC-DC Converters Input
 40 - 60 V, Output up to 42 A / 504 W

28701-BMR49203 03 revB May 2021

© Flex

STATUS_VOUT (0x7A)

Description: Returns Vout-related fault/warning status bits.

Bit	Function	Description	Value	Description
7	Vout Overvoltage Fault	Vout Overvoltage Fault.	0	No Fault.
			1	Fault.
6	Vout Overvoltage Warning	Vout Overvoltage Warning.	0	No Warning.
			1	Warning.
5	Vout Undervoltage Warning	Vout Undervoltage Warning.	0	No Warning.
			1	Warning.
4	Vout Undervoltage Fault	Vout Undervoltage Fault.	0	No Fault.
			1	Fault.
3	Vout Max Warning	Vout Max Warning (An attempt has been made to set the output voltage to value higher than allowed by the Vout Max command (Section 13.5).	0	No Warning.
			1	Warning.
2	Ton Max Fault	Ton-Max Fault.	0	No Fault
			1	Fault.
1	Toff Max Warning	Toff Max Warning.	0	No Warning.
			1	Warning.

STATUS_IOUT (0x7B)

Description: Returns Iout-related fault/warning status bits.

Bit	Function	Description	Value	Description
7	Iout Overcurrent Fault	Iout Overcurrent Fault.	0	No Fault.
			1	Fault.
6	Iout Overcurrent And Low Voltage Fault	Iout Overcurrent and low voltage fault.	0	No Fault.
			1	Fault.
5	Iout Over Current Warning	Iout Overcurrent Warning.	0	No Warning.
			1	Warning.
4	Iout Undercurrent Fault	Iout Undercurrent Fault.	0	No Fault.
			1	Fault.

STATUS_INPUT (0x7C)

Description: Returns VIN/IIN-related fault/warning status bits.

Bit	Function	Description	Value	Description
7	Vin Overvoltage Fault	Vin Overvoltage Fault.	0	No Fault.
			1	Fault.
6	Vin Overvoltage Warning	VIN Overvoltage Warning.	0	No Warning.
			1	Warning.
5	Vin Undervoltage Warning	Vin Undervoltage Warning.	0	No Warning.
			1	Warning.
4	Vin Undervoltage Fault	Vin Undervoltage Fault.	0	No Fault.
			1	Fault.
3	Insufficient Vin	Asserted when either the input voltage has never exceeded the input turn-on threshold Vin-On, or if the unit did start, the input voltage decreased below the turn-off threshold.	0	No Insufficient VIN encountered yet.
			1	Insufficient Unit is off.

BMR492 series DC-DC Converters Input
 40 - 60 V, Output up to 42 A / 504 W

28701-BMR49203 03 revB May 2021

© Flex

STATUS_TEMPERATURE (0x7D)

Description: Returns the temperature-related fault/warning status bits

Bit	Function	Description	Value	Description
7	Overtemperature Fault	Overtemperature Fault.	0	No Fault.
			1	Fault.
6	Overtemperature Warning	Overtemperature Warning.	0	No Warning.
			1	Warning.
5	Undertemperature Warning	Undertemperature Warning.	0	No Warning.
			1	Warning.
4	Undertemperature Fault	Undertemperature Fault.	0	No Fault.
			1	Fault.

STATUS_CML (0x7E)

Description: Returns Communication/Logic/Memory-related fault/warning status bits.

Bit	Function	Description	Value	Description
7	Invalid Or Unsupported Command Received	Invalid Or Unsupported Command Received.	0	No Invalid Command Received.
			1	Invalid Command Received.
6	Invalid Or Unsupported Data Received	Invalid Or Unsupported Data Received.	0	No Invalid Data Received.
			1	Invalid Data Received.
5	Packet Error Check Failed	Packet Error Check Failed.	0	No Failure.
			1	Failure.
4	Memory Fault Detected	Memory Fault Detected.	0	No Fault.
			1	Fault.
1	Other Communication Fault	A communication fault other than the ones listed in this table has occurred.	0	No Fault.
			1	Fault.
0	Memory Or Logic Fault	Other Memory Or Logic Fault has occurred.	0	No Fault.
			1	Fault.

READ_VIN (0x88)

Description: Returns the measured input voltage.

Bit	Description	Format	Unit
15:0	Returns the input voltage reading.	Linear	V

READ_VOUT (0x8B)

Description: Returns the measured output voltage.

Bit	Description	Format	Unit
15:0	Returns the measured output voltage.	Vout Mode Unsigned	V

READ_IOUT (0x8C)

Description: Returns the measured output current.

Bit	Description	Format	Unit
15:0	The device will NACK this command when not enabled and not in the USER_CONFIG monitor mode.	Linear	A

READ_TEMPERATURE_1 (0x8D)

Description: Returns the measured temperature (internal).

Bit	Description	Format	Unit
15:0		Linear	°C

BMR492 series DC-DC Converters Input
 40 - 60 V, Output up to 42 A / 504 W

28701-BMR49203 03 revB May 2021

© Flex

READ_DUTY_CYCLE (0x94)

Description: Returns the measured duty cycle in percent.

Bit	Description	Format	Unit
15:0	Returns the target duty cycle during the ENABLE state. The device will NACK this command when not enabled and not in the USER_CONFIG monitor mode.	Direct	%

READ_FREQUENCY (0x95)

Description: Returns the measured SYNC frequency.

Bit	Description	Format	Unit
15:0	Returns the measured operating switch frequency. The device will NACK this command when not enabled and not in the USER_CONFIG monitor mode.	Linear	kHz

PMBUS_REVISION (0x98)

Description: Returns the PMBus revision number for this device.

Bit	Function	Description	Value	Function	Description
7:4	Part I Revision	Part I Revision.	0x0	1.0	Part I Revision 1.0.
			0x1	1.1	Part I Revision 1.1.
			0x2	1.2	Part I Revision 1.2.
			0x3	1.3	Part I Revision 1.3.
3:0	Part II Revision	Part II Revision.	0x0	1.0	Part II Revision 1.0.
			0x1	1.1	Part II Revision 1.1.
			0x2	1.2	Part II Revision 1.2.
			0x3	1.3	Part II Revision 1.3.

MFR_ID (0x99)

Description: Sets the Manufacturers ID

Bit	Description	Format
95:0	Maximum of 12 characters.	ASCII

MFR_MODEL (0x9A)

Description: Sets the MFR MODEL string.

Bit	Description	Format
159:0	Maximum of 20 characters.	ASCII

MFR_REVISION (0x9B)

Description: Sets the MFR revision string.

Bit	Description	Format
95:0	Maximum of 12 characters.	ASCII

MFR_LOCATION (0x9C)

Description: Sets the MFR location string.

Bit	Description	Format
95:0	Maximum of 12 characters.	ASCII

MFR_DATE (0x9D)

Description: This command returns the date the regulator was manufactured.

Bit	Description	Format
95:0	Maximum of 12 characters.	ASCII

BMR492 series DC-DC Converters Input
 40 - 60 V, Output up to 42 A / 504 W

28701-BMR49203 03 revB May 2021

© Flex

MFR_SERIAL (0x9E)

Description: This command returns a string of 13 characters and numbers that provides a unique identification of the regulator.

Bit	Description	Format
159:0	Maximum of 20 characters.	ASCII

MFR_VIN_MIN (0xA0)

Description: The MFR_VIN_MIN command sets or retrieves the minimum rated value, in Volts, of the input voltage.

Bit	Description	Format	Unit
15:0	Sets the minimum allowed input voltage.	Linear	V

MFR_VIN_MAX (0xA1)

Description: The MFR_VIN_MAX command sets or retrieves the maximum rated value, in Volts, of the input voltage.

Bit	Description	Format	Unit
15:0	Sets the maximum allowed input voltage.	Linear	V

MFR_VOUT_MIN (0xA4)

Description: The MFR_VOUT_MIN command sets or retrieves the minimum rated value, in Volts, to which the output voltage may be set.

Bit	Description	Format	Unit
15:0	Sets the minimum allowed output voltage.	Vout Mode Unsigned	V

MFR_VOUT_MAX (0xA5)

Description: The MFR_VOUT_MAX command sets or retrieves the maximum rated value, in Volts, to which the output voltage may be set.

Bit	Description	Format	Unit
15:0	Sets the maximum allowed output voltage.	Vout Mode Unsigned	V

MFR_IOUT_MAX (0xA6)

Description: The MFR_IOUT_MAX command sets or retrieves the maximum rated value, in Amperes, to which the output may be loaded.

Bit	Description	Format	Unit
15:0	Sets the maximum allowed output Current.	Linear	A

FW_CONFIG_REGULATION (0xC5)

Description: FW CONFIG REGULATION parameter

Bit	Description	Value	Function	Description
0	Enable diode emulation at startup	0	Disabled	
		1	Enabled	

BMR492 series DC-DC Converters Input
 40 - 60 V, Output up to 42 A / 504 W

28701-BMR49203 03 revB May 2021

© Flex

FW_CONFIG_FAULTS (0xC8)

Description: FW CONFIG FAULTS parameter

Bit	Function	Description	Value	Function	Description
7:6	Vout Delay Unit	Vout_Delay_Unit Time unit for retry responses. 0: 1ms, 1: 4ms, 2: 16ms, 3: 256ms	00	1ms/unit	Vout Delay Unit Time unit for retry responses
			01	4ms/unit	Vout Delay Unit Time unit for retry responses
			10	16ms/unit	Vout Delay Unit Time unit for retry responses
			11	256ms/unit	Vout Delay Unit Time unit for retry responses
5:4	Vin Delay Unit	Vin_Delay_Unit Time unit for retry responses. 0: 1ms, 1: 4ms, 2: 16ms, 3: 256ms	00	1ms/unit	Vin Delay Unit Time unit for retry responses
			01	4ms/unit	Vin Delay Unit Time unit for retry responses
			10	16ms/unit	Vin Delay Unit Time unit for retry responses
			11	256ms/unit	Vin Delay Unit Time unit for retry responses
3:2	Iout Delay Unit	IOUT_Delay_Unit Time unit for retry responses. 0: 1ms, 1: 4ms, 2: 16ms, 3: 256ms	00	1ms/unit	IOUT Delay Unit Time unit for retry responses
			01	4ms/unit	IOUT Delay Unit Time unit for retry responses
			10	16ms/unit	IOUT Delay Unit Time unit for retry responses
			11	256ms/unit	IOUT Delay Unit Time unit for retry responses
1:0	Temperature Delay Unit	Temperature_Delay_Unit Time unit for retry responses. 0: 1ms, 1: 4ms, 2: 16ms, 3: 256ms	00	1ms/unit	Temperature Delay Unit Time unit for retry responses
			01	4ms/unit	Temperature Delay Unit Time unit for retry responses
			10	16ms/unit	Temperature Delay Unit Time unit for retry responses
			11	256ms/unit	Temperature Delay Unit Time unit for retry responses

FW_CONFIG_PMBUS (0xC9)

Description: The GPIO selection for the fault select, Power good select, and enable select has to be unique, please choose different values for these configurations. The overall I2C address (Base + offset or XADDR1/XADDR2) and PMBus (Base + offset or XADDR1/XADDR2) can not be same, please configure different address either base or offset.

Bit	Function	Description	Format
31:24	PMBus Base Addr	Base Address for PMBus offset to start from	Integer Unsigned
23:17	PMBus Addr Offset	PMBUS Address offset when resistor offset Not enabled	Integer Unsigned

Bit	Function	Description	Value	Function	Description
39	Power good polarity	Power good polarity (1:active high; 0: active low).	0	Active low	
			1	Active high	
32	Control pin polarity	Control pin polarity (1:active high; 0: active low).	0	Active low	
			1	Active high	
16	PMBus Addr Offset Resistor Enable	PMBus_addr_offset_enable Enable PMBUS Address Offset via resistor	0	Disabled	
			1	Enabled	

BMR492 series DC-DC Converters Input
40 - 60 V, Output up to 42 A / 504 W

28701-BMR49203 03 revB May 2021

© Flex

MFR_IOUT_OC_FAST_FAULT_RESPONSE (0xCA)

Description: Output over current fault response.

Bit	Function	Description	Value	Function	Description
7:6	Response	For all values of bits [7:6], the device: Sets the corresponding fault bit in the status registers and If the device supports notifying the host, it does so.	00	Ignore Fault	The PMBus device continues to operate indefinitely while maintaining the output current at the value set by IOUT_OC_FAULT_LIMIT without regard to the output voltage (known as constant-current or brickwall limiting).
			11	Shutdown and Retry	The PMBus device continues to operate, maintaining the output current at the value set by IOUT_OC_FAST_FAULT_LIMIT without regard to the output voltage, for the delay time set by bits [2:0] and the delay time units for specified in the IOUT_OC_FAST_FAULT_RESPONSE. If the device is still operating in current limiting at the end of the delay time, the device responds as programmed by the Retry Setting in bits [5:3].
5:3	Retries	The device attempts to restart the number of times set by these bits. 000b means the device does not attempt a restart. 111b means the device attempts restarting continuously.	000	Do Not Retry	A zero value for the Retry Setting means that the unit does not attempt to restart. The output remains disabled until the fault is cleared (Section 10.7).
			001	Retry Once	The PMBus device attempts to restart 1 time. If the device fails to restart, it disables the output and remains off until the fault is cleared as described in Section 10.7. The time between the start of each attempt to restart is set by the value in bits [2:] along with the delay time unit specified for that particular fault.
			010	Retry Twice	The PMBus device attempts to restart 2 times. If the device fails to restart, it disables the output and remains off until the fault is cleared as described in Section 10.7. The time between the start of each attempt to restart is set by the value in bits [2:] along with the delay time unit specified for that particular fault.
			011	Retry 3 times	The PMBus device attempts to restart 3 times. If the device fails to restart, it disables the output and remains off until the fault is cleared as described in Section 10.7. The time between the start of each attempt to restart is set by the value in bits [2:] along with the delay time unit specified for that particular fault.

BMR492 series DC-DC Converters Input
 40 - 60 V, Output up to 42 A / 504 W

28701-BMR49203 03 revB May 2021

© Flex

Bit	Function	Description	Value	Function	Description
			100	Retry 4 times	The PMBus device attempts to restart 4 times. If the device fails to restart, it disables the output and remains off until the fault is cleared as described in Section 10.7. The time between the start of each attempt to restart is set by the value in bits [2:] along with the delay time unit specified for that particular fault.
			101	Retry 5 times	The PMBus device attempts to restart 5 times. If the device fails to restart, it disables the output and remains off until the fault is cleared as described in Section 10.7. The time between the start of each attempt to restart is set by the value in bits [2:] along with the delay time unit specified for that particular fault.
			110	Retry 6 times	The PMBus device attempts to restart 6 times. If the device fails to restart, it disables the output and remains off until the fault is cleared as described in Section 10.7. The time between the start of each attempt to restart is set by the value in bits [2:] along with the delay time unit specified for that particular fault.
			111	Retry Continuously	The PMBus device attempts to restart continuously, without limitation, until it is commanded OFF (by the CONTROL pin or OPERATION command or both), bias power is removed, or another fault condition causes the unit to shut down.
2:0	Retry Time and Delay Time	Number of delay time units. Used for either the amount of time the device is to continue operating after a fault is detected or for the amount of time between attempts to restart. The time unit is set in register 0xC8.	0	1	
			1	2	
			2	4	
			3	8	
			4	16	
			5	32	
			6	64	
			7	128	

MFR_IOUT_OC_FAST_FAULT_LIMIT (0xD1)

Description: The MFR_IOUT_OC_FAST_FAULT_LIMIT command sets or retrieves Iout fast overcurrent fault threshold, in Amperes.

Bit	Description	Format	Unit
15:0	Sets Iout fast over-current fault threshold.	Integer Unsigned	A

BMR492 series DC-DC Converters Input
 40 - 60 V, Output up to 42 A / 504 W

28701-BMR49203 03 revB May 2021

© Flex

MFR_SELECT_TEMPERATURE_SENSOR (0xDC)

Description: Select which temperature sensor, internal one or external remote temperature sensor, is used.

Bit	Function	Description	Value	Function	Description
4:3	Fault Source Select	Select which temperature sensor, internal one or external remote temperature sensor, is used.	00	Temp A	Temp A temperature sensor selected.
			01	Temp B	Temp B temperature sensor selected.
			10	Temp I	Temp I temperature sensor selected.
2:0	READ_TEMPERATURE_1 READ_TEMPERATURE_2 Source Select	READ_TEMPERATURE_1 READ_TEMPERATURE_2 Source Select.	000	TempA TempB	TempA (External Temperature sensor A) TempB (External Temperature sensor B).
			001	TempA TempI	TempA (External Temperature sensor A) TempI (Internal Temperature sensor).
			010	TempB TempA	TempB (External Temperature sensor B) TempA (External Temperature sensor A).
			011	TempB TempI	TempB (External Temperature sensor B) TempI (Internal Temperature sensor).
			100	TempI TempA	TempI (Internal Temperature sensor) TempA (External Temperature sensor A).
			101	TempI TempB	TempI (Internal Temperature sensor) TempB (External Temperature sensor B).

MFR_FILTER_COEFF (0xE8)

Description: Mfr. pid coefficients

Bit	Function	Description	Format
30:24	PID KD	PID derivative coefficient	Integer Unsigned
23:18	PID KI	PID integral coefficient	Integer Unsigned
17:12	PID KP	PID proportional coefficient	Integer Unsigned
11:6	PID pre-filter 2	PID pre-filter 2 coefficient	Integer Unsigned
5:0	PID pre-filter 1	Pid pre-filter 1 coefficient	Integer Unsigned

MFR_IOUT_APC (0xEA)

Description: The iout apc gain.

Bit	Description	Format	Unit
15:0	SSet the iout apc gain. the format is Linear 11, Exponent is -9 or -8 (User selection possible). The LSB varies with isen_gain_mode - ISEN_LSB/Secondary current sense resistor (Rsense).	Linear	A

MFR_MIN_PW (0xEB)

Description: The actual minimum output pulse.

Bit	Description	Format	Unit
7:0	The actual minimum output pulse.	Fixed Point Unsigned	ns