

## BMR684

### 700W digital quarter brick

The BMR684 is a high-density digital solution DC/DC converter for telecom application. The impressive performance of this converter includes an efficiency reaching 96.0% at 48 V<sub>in</sub> at full load and the baseplate operating temperature up to 100°C.

The BMR684 is a single output regulated DC/DC converter with standard quarter brick format. It delivers up to 14A output current with 50V output voltage.

This converter is designed for through-hole mounting using wave solder process.



### Key features

- High efficiency with 96.0%
- 1500Vdc input to output isolation
- Monotonic start-up
- Input under voltage protection
- Output over voltage protection
- Output short-circuit protection
- Over temperature protection
- Remote control
- Remote sense function

### Soldering methods

- Wave soldering
- Manual soldering

### Key electrical information

Parameter	Values
Input range	36-75V
Output voltage	50V
Output current	14A
Output power	700W

### Mechanical

58.4 x 36.8 x 12.7 mm / 2.30 x 1.45 x 0.5 in

### Application areas

- Telecom
- Datacom

## Product options

The table below describes the different product options.

Example: BMR684 1 1 00 /001						B	Definitions
<b>Product family</b>	BMR684						
<b>Pin length options</b>		1					1 = 5.33 mm / 0.21 in 2 = 3.69 mm / 0.15 in
<b>Baseplate / HS option</b>			1				1 = standard baseplate
<b>Other hardware options</b>				00			00 = 7-pin digital header 01 = without digital header
<b>Configuration code</b>					/001		/001 =50 V <sub>out</sub> standard config. for 36-75 Vin N logic /002 =50 V <sub>out</sub> standard config. for 36-75 Vin P logic
<b>Packaging options</b>						B	B = Foam Tray

For more information, please refer to Part 3 [Mechanical information](#).

If you do not find the variant you are looking for, please contact us at [Flex Power Modules](#).

## Order number examples

Part number	V <sub>in</sub>	outputs	configuration
BMR684 1100/001B	36-75V	50V / 14A/ 700 W	5.33 mm pins / baseplate / 7-pin digital header / negative logic /foam tray

## Part 1: Electrical specifications

### Absolute maximum ratings

Stress in excess of our defined *absolute maximum ratings* may cause permanent damage to the converter. Absolute maximum ratings, also referred to as *non-destructive limits*, are normally tested with one parameter at a time exceeding the limits in the electrical specification.

Characteristics	min	typ	max	Unit
Ambient operating temperature ( $T_A$ )	-40		85	°C
Operating temperature ( $T_{P1}$ )	-40		125	°C
Baseplate operating temperature ( $T_{P2}$ )	-40		100	°C
Storage temperature	-55		125	°C
Input voltage ( $V_{in}$ )	-0.5		80	V
Input voltage transient (100 ms)			100	V
Input capacitance	470			μF
Output capacitance	1000		3400	μF
Isolation voltage (input to output)			1500	V
Isolation voltage (input to baseplate)			750	V
Isolation voltage (baseplate to output)			750	V
Adjust pin voltage	-0.5		5	V
Remote control pin voltage (positive logic)	-0.5		6	V
Remote control pin voltage (negative logic)	-0.5		6	V

### Reliability

Failure rate ( $\lambda$ ) and mean time between failures (MTBF=  $1/\lambda$ ) are calculated based on *Telcordia SR-332 Issue 4: Method 1, Case 3, (80% of  $I_{out\_TDP}$ ,  $T_{P1}=40^\circ\text{C}$ , Airflow=200 LFM)*.

	Mean	90% confidence level	Unit
Steady-state failure rate ( $\lambda$ )	162	191	nfailures/h
Standard deviation ( $\sigma$ )	22.8		nfailures/h
MTBF	6.17	5.23	MHr

## Typical application diagram

Capacitor values are defined in the Electrical Specification tables. The EMI filter is defined in Part 2: EMC.

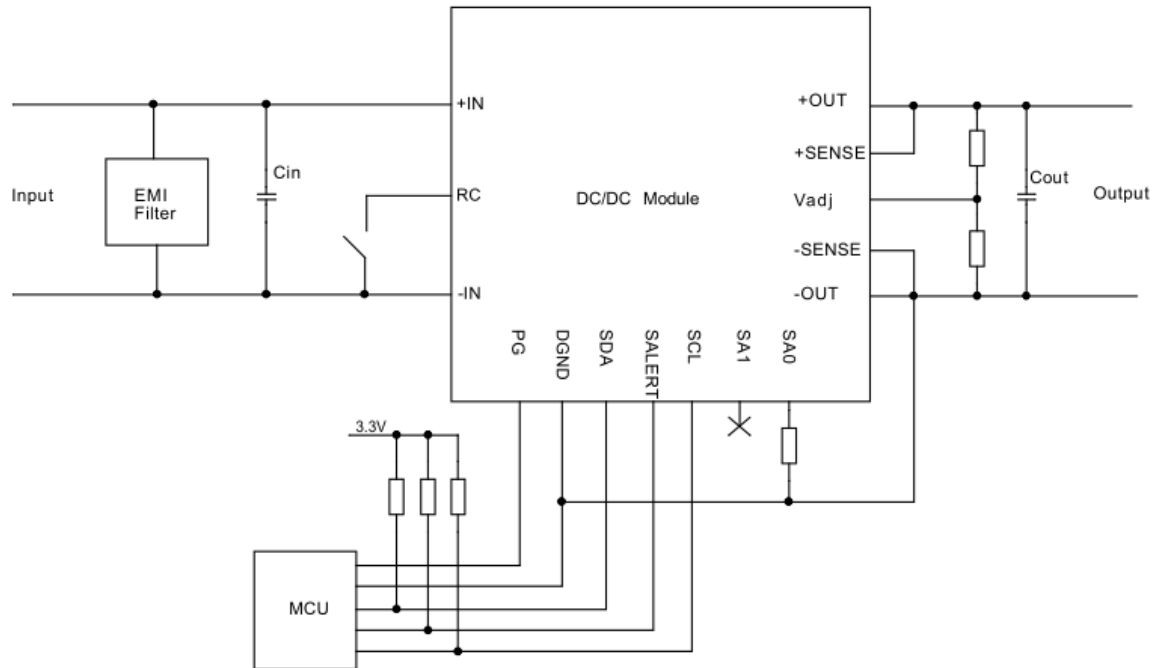

**Electrical specifications for BMR684 1100/001****50 V, 14 A / 700 W**

Min and Max values are valid for:  $T_{P1} = -40$  to  $+85$  °C,  $V_{in} = 36$  to  $75$  V, unless otherwise specified under conditions. Typical values given at:  $T_{P1} = +25$  °C,  $V_{in} = 48$  V, max  $I_o$ , unless otherwise specified under conditions. Additional external  $C_{in} = 470$   $\mu$ F,  $C_{out} = 1$  mF.

Characteristic	conditions	minimum	typical	maximum	unit
<b>Key features</b>					
Efficiency ( $\eta$ )	50% of max $I_o$ , $V_{in} = 48$ V	93.5	95.5		%
	100% of max $I_o$ , $V_{in} = 48$ V	94.0	96.0		%
	50% of max $I_o$ , $V_{in} = 53$ V	93.0	95.0		%
	100% of max $I_o$ , $V_{in} = 53$ V	93.8	95.8		%
Output power		0		700	W
Power dissipation	100% of max $I_o$		30	50	W
Switching frequency ( $f_s$ )	0-100 % of max $I_o$	170	180	190	kHz
Recommend capacitive load		1000	1360	3400	$\mu$ F
<b>Input characteristics</b>					
Input voltage range ( $V_{in}$ )		36	48	75	V
Input idling power	$I_o = 0$ A		9		W
Input standby power	(turned off with RC)		0.8		W
Recommended external input capacitance		470			$\mu$ F

**Electrical specifications for BMR684 1100/001****50 V, 14 A / 700 W**

Characteristic	conditions	minimum	typical	maximum	unit
<b>Output characteristics</b>					
Output voltage initial setting and accuracy	$T_{P1} = +25\text{ °C}$ , $V_{in} = 48\text{ V}$ , $I_o = 0\text{ A}$	49	50	51	V
Output voltage tolerance band	0-100% of max $I_o$	48.5		51.5	V
Output adjust range	0-100% of max $I_o$	25		55	V
Idling voltage	$I_o = 0\text{ A}$	48.5		51.5	V
Line regulation	0 – 100% of max $I_o$		30	200	mV
Load regulation	0 - 100% of max $I_o$		30	200	mV
Output current ( $I_o$ )		0		14	A
Load transient voltage deviation	Load step 25-75-25% of max $I_o$ , $di/dt = 1\text{ A}/\mu\text{s}$ . See Note 1		$\pm 250$	$\pm 750$	mV
Load transient recovery time			200	500	$\mu\text{s}$
Output ripple & noise	max $I_o$ , $10\text{ }\mu\text{F} + 0.1\text{ }\mu\text{F}$ , 20MHz bandwidth		200	400	mV <sub>p-p</sub>

Note 1:  $C_{out}$  is 2 x 680  $\mu\text{F}$  aluminum electrolytic capacitor

**Electrical specifications for BMR684 1100/001****50 V, 14 A / 700 W**

Characteristic	conditions	minimum	typical	maximum	unit
<b>On/off control</b>					
Turn-on input voltage	Increasing input voltage	30.5	32.5	34.5	V
Turn-off input voltage	Decreasing input voltage	29.5	31	32.5	V
Turn-on delay time (from RC toggle to $V_{out}$ start to ramp up)			80		ms
Turn-on rise time (from 0% to 100% of $V_{out}$ )			90		ms
RC start-up time (from RC toggle to 100% of $V_{out}$ )		140	170	200	ms
Start-up time (from $V_{in}$ connection to 100% of $V_{out}$ )		150	180	210	ms
RC sink current		1.5			mA
RC logic high voltage		3.3		6	V
RC logic low voltage		0		0.8	V
<b>Protection features</b>					
Output over current protection (OCP)	$T_{P1} < \max T_{P1}$	16	18	20	A
Output over current protection (OCP) response		Disable and retry continuously			
Short circuit current	$T_{P1} = 25^{\circ}\text{C}$ , See Note 2		5	7	A
Output under current protection (UCP)			-8		A
Output under current protection (UCP) response		Disable and retry continuously			
Output over voltage protection (OVP)			58.5		V
Output over voltage protection (OVP) response		Disable and retry continuously			
Over temperature protection (OTP)	Note 3		110		$^{\circ}\text{C}$
Over temperature protection (OTP) recovery	Note 3		90		$^{\circ}\text{C}$
Over temperature protection (OTP) response		Disable until fault is cleared			

Note 2: Hiccup mode, RMS value

Note 3: Temperature measured at P2

**Electrical specifications for BMR684 1100/001****50 V, 14 A / 700 W**

Command	Conditions	minimum	typical	maximum	Unit
<b>Monitoring accuracy</b>					
Input voltage READ_VIN			±125		mV
Output voltage READ_VOUT			±40		mV
Output current READ_IOUT			±0.25		A
Temperature READ_TEMPERATURE_1	Temperature sensor, -40 - 120 °C		±5		°C

This product is supported by the [Flex Power Designer tool](#).



**Electrical graphs for BMR684 1100/001**  
**50 V, 14 A / 700 W**

**Efficiency**

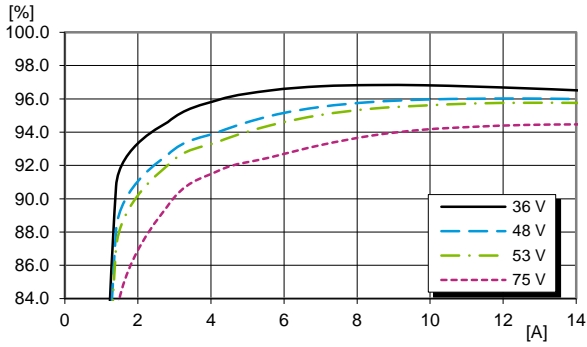

Efficiency vs. output power and input voltage at  $T_{P1} = +25^{\circ}$

**Power Dissipation**

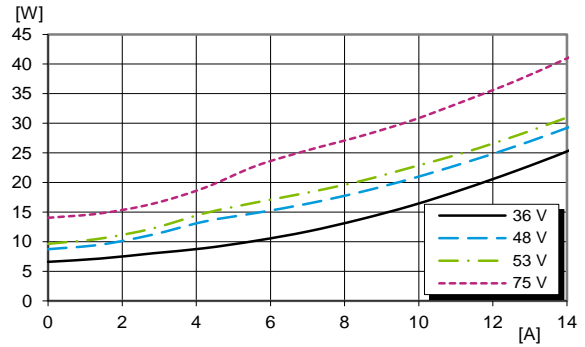

Dissipated power vs. load power at  $T_{P1} = +25^{\circ}$

**Load Regulation**

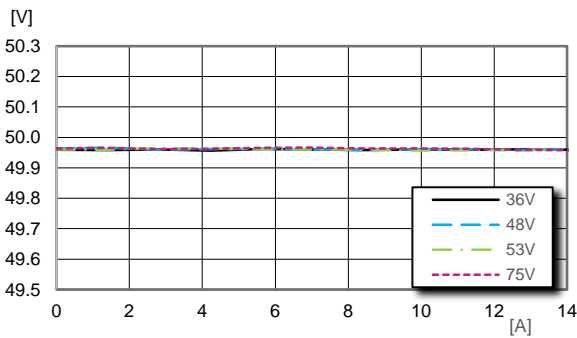

Output voltage vs. load current at  $T_{P1} = +25^{\circ}$

**Line Regulation**

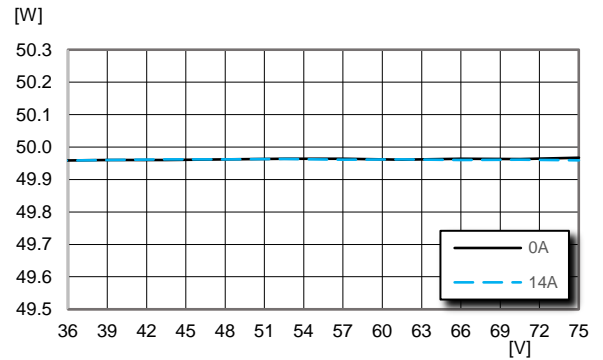

Output voltage vs. input voltage at  $T_{P1} = +25^{\circ}$

**Current Limit**

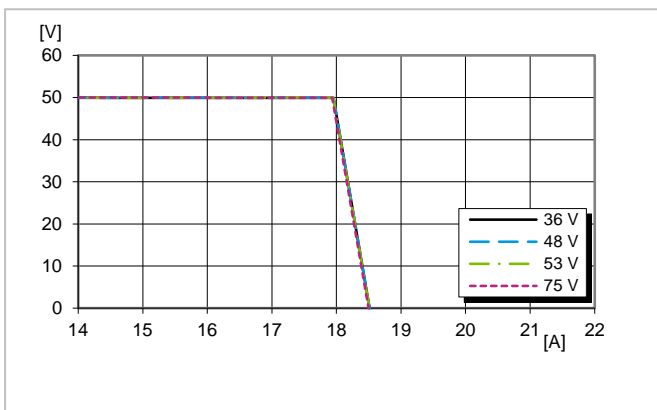

Output voltage vs. load current at  $I_o > \max I_o$ ,  $T_{P1} = +25^{\circ}$

**Maximum Adjustable Output Voltage**

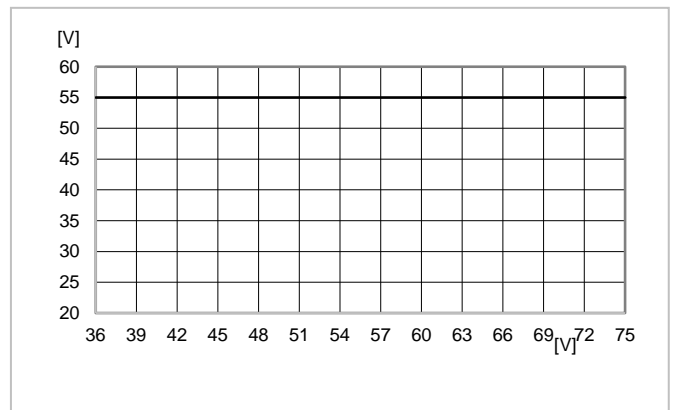

Maximum Adjustable output voltage vs. input voltage at  $T_{P1} = +25^{\circ}$

## Part 1: Electrical specifications

## Electrical graphs for BMR684 1100/001

50 V, 14 A / 700 W

## Start-up

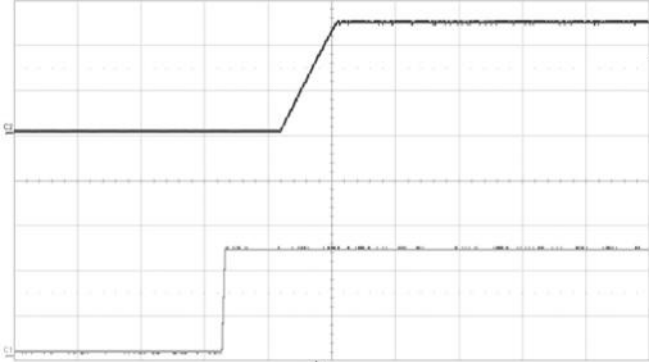

Start-up enabled by connecting  $V_{in}$  at:  $T_{P1} = +25\text{ }^{\circ}\text{C}$ ,  $V_{in} = 48\text{ V}$ ,  $I_o = 14\text{ A}$  resistive load.

Top trace: output voltage 20 V/div. Bottom trace: input voltage 20 V/div. Time scale: 100 ms/div.

## Shut-down

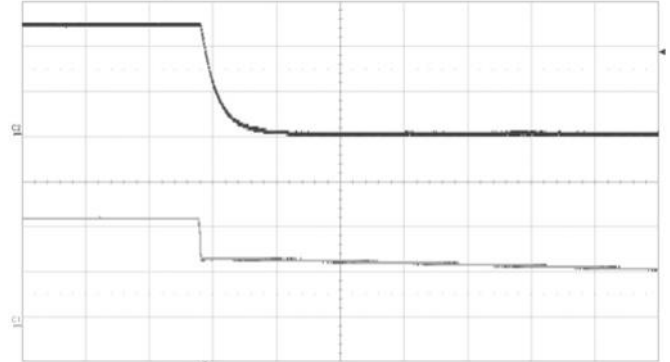

Shut-down enabled by disconnecting  $V_{in}$  at:  $T_{P1} = +25\text{ }^{\circ}\text{C}$ ,  $V_{in} = 48\text{ V}$ ,  $I_o = 14\text{ A}$  resistive load.

Top trace: output voltage 20 V/div. Bottom trace: input voltage 20 V/div. Time scale: 20 ms/div.

## Output Ripple &amp; Noise

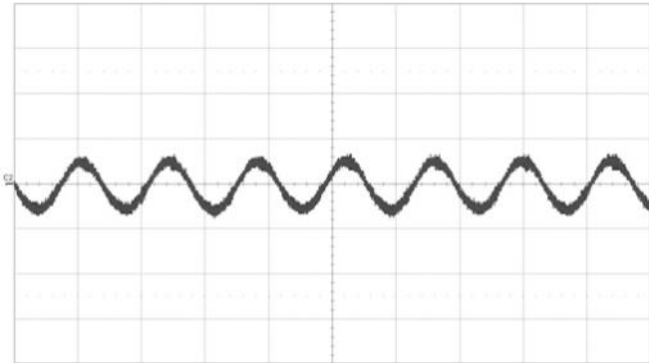

Output voltage ripple at  $V_{in} = 48\text{ V}$ ,  $I_o = 14\text{ A}$  resistive load,  $T_{P1} = +25\text{ }^{\circ}\text{C}$ , 20 MHz bandwidth

Voltage scale: 100 mV/div. Time scale: 2  $\mu\text{s}$ /div

## Output Load Transient Response

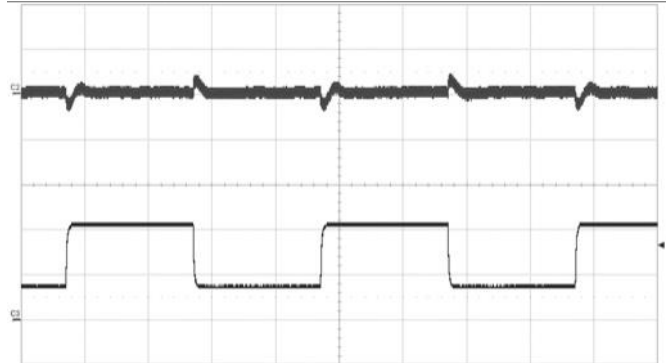

Output voltage response to output current change (3.5-10.5-3.5 A) at  $V_{in} = 48\text{ V}$ ,  $C_o = 2 \times 680\text{ }\mu\text{F}$ ,  $T_{P1} = +25\text{ }^{\circ}\text{C}$ ,  $di/dt = 1\text{ A}/\mu\text{s}$ .

Top trace: output voltage (500mV/div). Bottom trace: output current (5A/div), time scale: 500  $\mu\text{s}$ /div

## Part 2: EMC

### EMC specifications

Conducted EMI measured according to EN55022 / EN55032, CISPR 22 / CISPR 32 and FCC part 15J (see test set-up below). The fundamental switching frequency is 180 kHz for BMR684. The EMI characteristics below is measured at  $V_{in} = 48\text{ V}$  and max  $I_{out}$ .

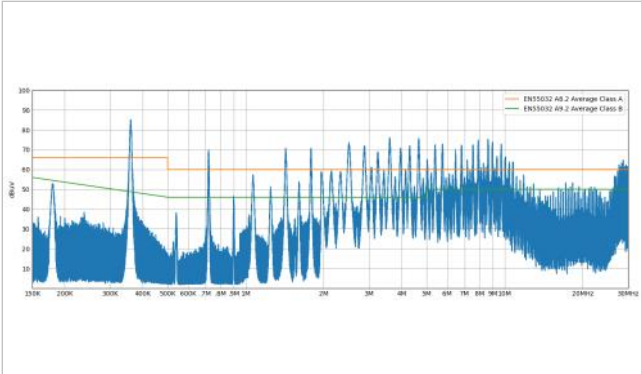

EMI without filter. EN55032 test method and limits are the same as EN55022.

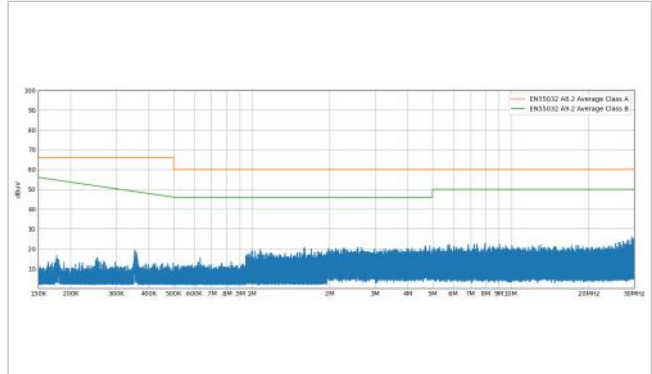

EMI with filter. EN55022 test methods and limits are the same as EN55032

### Optional external filter for Class B

Suggested external input filter in order to meet Class B in EN 55022 / EN 55032, CISPR 22 / CISPR 32 and FCC part 15J.

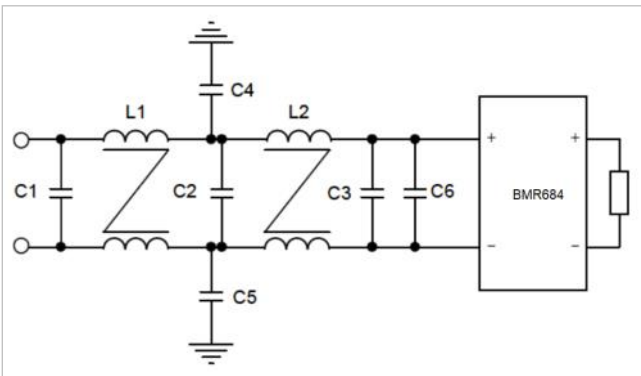

Filter components:  
C1, C2 = 4 x 4.7 μF MLCC; C3 = 3 x 4.7 μF MLCC; C4, C5 = 2 x 10nF 2kV MLCC; C6 = 470 μF; L1, L2 = 0.63mH (Pulse P0469NL)

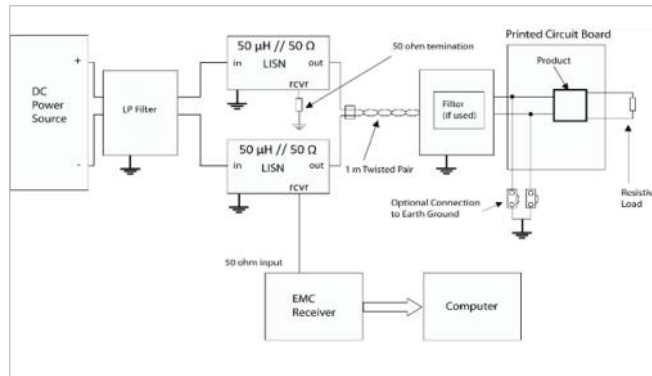

Test set-up

### Layout recommendations

The radiated EMI performance of the product will depend on the PWB layout and ground layer design. It is also important to consider the stand-off of the product. If a ground layer is used, it should be connected to the output of the product and the equipment ground or chassis.

A ground layer will increase the stray capacitance in the PWB and improve the high frequency EMC performance.

### Part 3: Mechanical information

#### BMR684 : baseplate version

The mechanical information is based on a module which is hole mounted and has a baseplate.

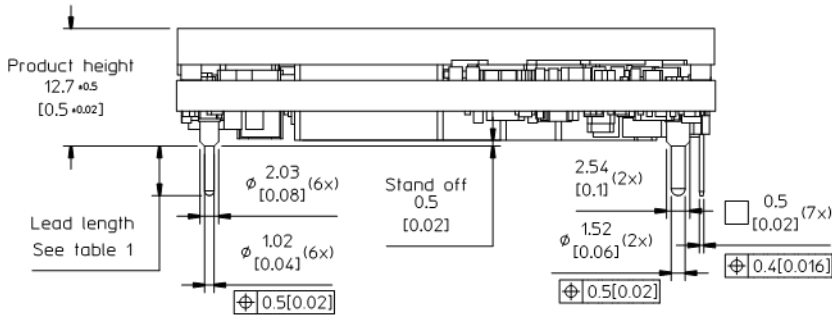

TOP VIEW

Pin position refer footprint recommendation

58.4  $\pm$ 0.5 [2.299  $\pm$ 0.02]

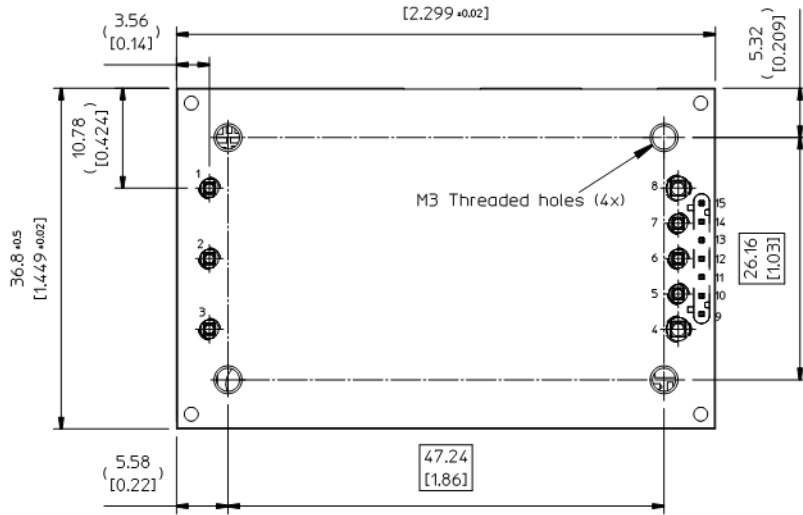
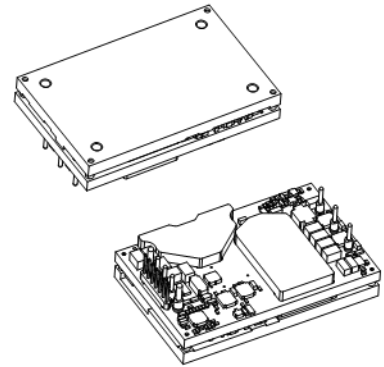

Recommended footprint - TOP VIEW

59.4 [2.339]

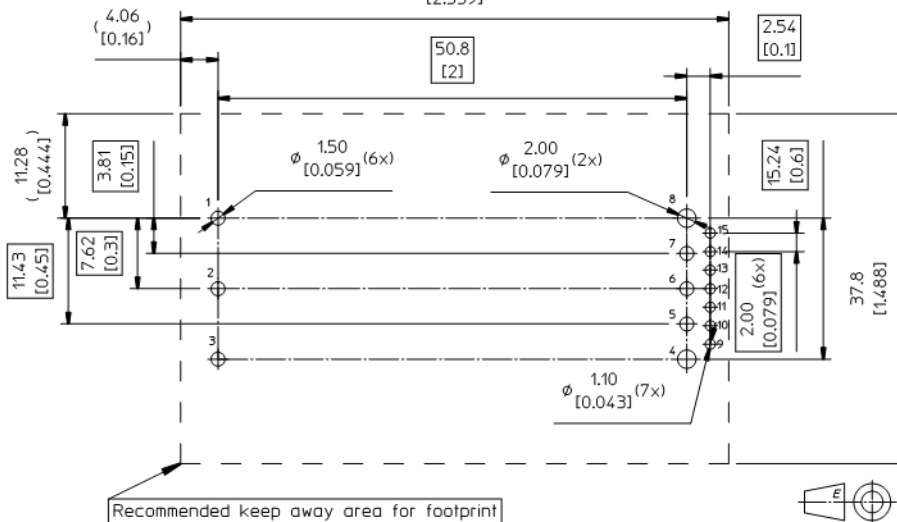

Table 1

Option	Lead length
1	5.33 [0.210]
2	3.69 [0.145]

**PIN SPECIFICATIONS**

Pin 1-15 Material: Copper alloy  
Plating: Min 0.1  $\mu$ m Au over 1-3  $\mu$ m Ni.

**CASE**

Material: Aluminium  
For screw attached apply mounting torque of max 0.44 Nm [3.9lbf].  
M3 screws must not protrude more than 3.4 mm [0.134] into the baseplate.

Recommended hole dimensions are only for reference. It is the end users decision based on different situations like production processes, substrate thickness etc.

Weight: typical 82 g  
All dimensions in mm [inch].  
Tolerances unless specified  
x.x  $\pm$ 0.5 mm [0.02],  
x.xx  $\pm$ 0.25 mm [0.01]  
(not applied on footprint or typical values)

## Connections for BMR684 1100/001

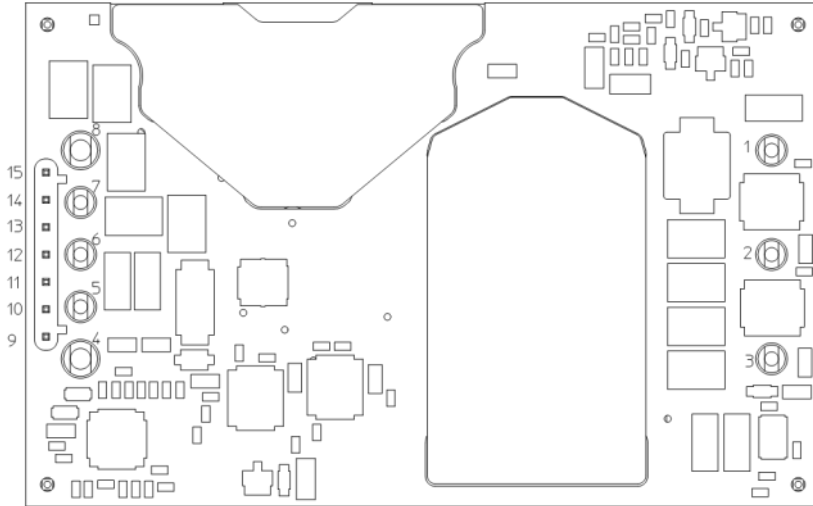

Pin layout, bottom view

Pin	Designation	Type (Power, Input, Output)	Description
1	+In	Power	Positive input
2	RC	I	Remote control
3	-In	Power	Negative input
4	-Out	Power	Negative output
5	-Sense	I	Remote sense negative
6	Vadj	I	Output voltage adjust
7	+Sense	I	Remote sense positive
8	+Out	Power	Positive output
9	PG	O	Power good
10	DGND	Power	PMBus ground
11	SDA	I/O	PMBus data
12	SALERT	O	PMBus alert
13	SCL	I/O	PMBus clock
14	SA1	I	PMBus address 1
15	SA0	I	PMBus address 0

## Part 4: Thermal considerations

### Thermal considerations

The products are designed to operate in different thermal environments and sufficient cooling must be provided to ensure reliable operation.

#### General

For products mounted on a PWB without a heatsink attached, cooling is achieved mainly by conduction, from the pins to the host board, and convection, which is dependent on the airflow across the product. Increased airflow enhances the cooling of the product. The wind speed and temperature are measured in a point upstream the device. The *output current derating graphs* found later in this section for each model provide the available output current vs. ambient air temperature and air velocity at  $V_{in} = 48\text{ V}$ .

For products using any form of heatsink structure a top spacing board and side airflow guides are used to ensure airflow hitting the module and not diverted away.

Distance between the tested device and the top space board and the side airflow guides are  $6.35\text{ mm} \pm 1\text{ mm}$ .

The product is tested on a  $254 \times 254\text{ mm}$ ,  $35\text{ }\mu\text{m}$  (1 oz), 16-layer test board mounted vertically in a wind tunnel.

For products with baseplate used in a sealed box/cold wall application, cooling is achieved mainly by conduction through the cold wall. The product is tested in a sealed box test set up with ambient temperatures  $85^\circ\text{C}$ . See [Design Note 028](#) for further details.

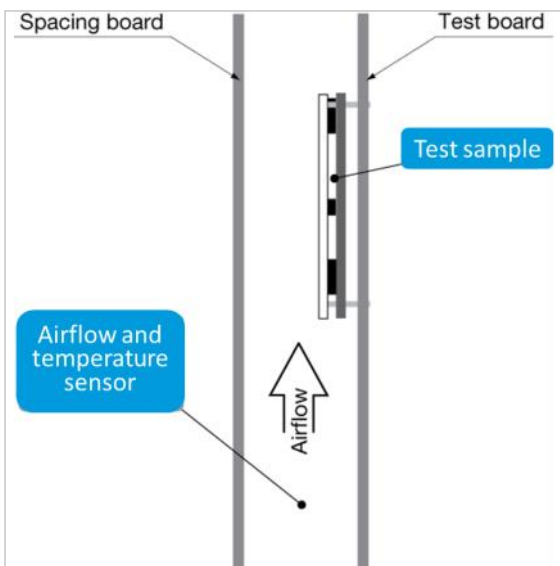

Picture: wind-tunnel test set-up

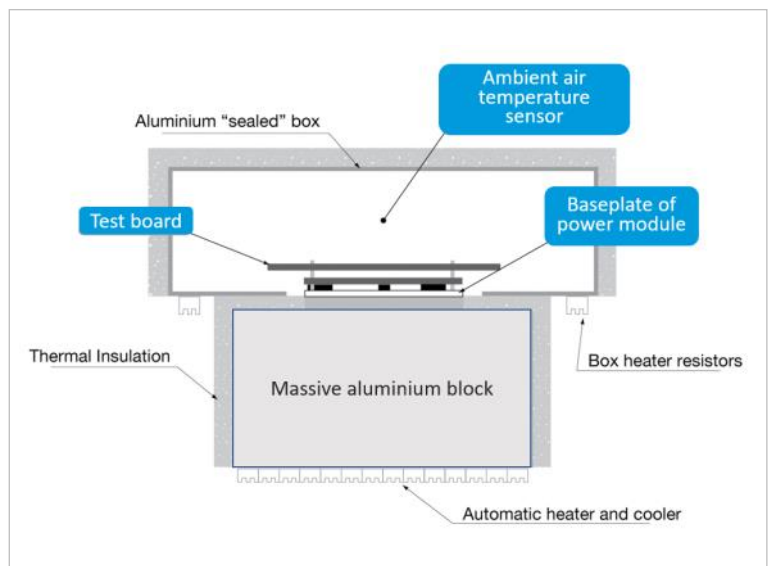

Picture: cold wall test set-up

## Part 4: Thermal considerations

**Definition of product operating temperature**

Proper thermal conditions can be verified by measuring the temperature at position P1 as shown below. The temperature at this position ( $T_{P1}$ ) should not exceed the maximum temperatures in the table below. The number of measurement points may vary with different thermal design and topology. Temperatures above maximum  $T_{P1}$ , measured at the reference point P1 are not allowed and may cause permanent damage.

Position	Description	Max. Temp.
P1	PCB	$T_{P1} = 125\text{ °C}$
P2	Base Plate	$T_{P2} = 100\text{ °C}$

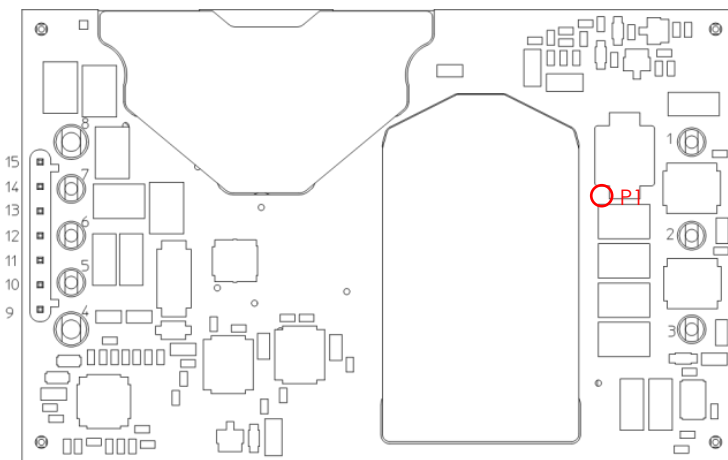

Temperature position P1, bottom view

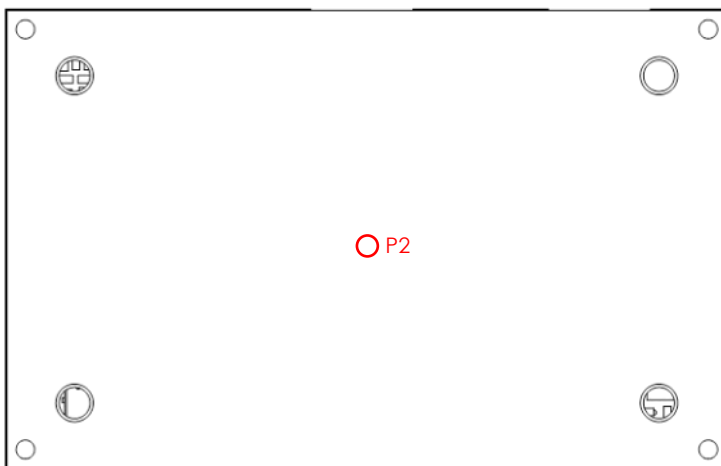

Temperature position P2, top view

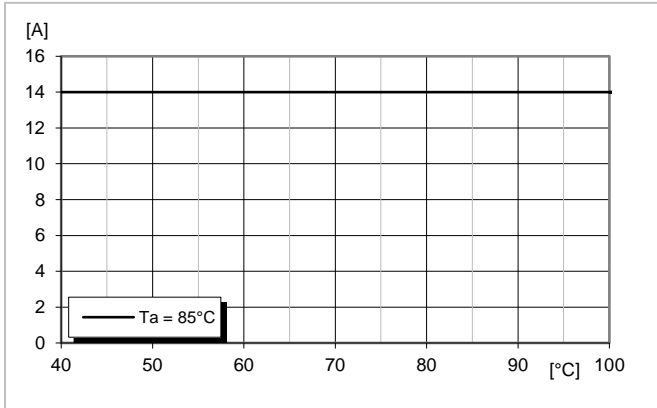
**Thermal graphs for BMR684 1100/001****Output current derating - Cold wall sealed box**

Available output current vs. base plate temperature,  $V_1 = 48\text{ V}$ .



## Part 5: Packaging

### Packaging information

**Blank option:** baseplate version (wave or hand soldering, NOT dry packed)

<b>Material</b>	Antistatic Polyethylene (PE) foam
<b>Surface resistance</b>	$10^5 < \text{ohm/square} < 10^{11}$
<b>Bakeability</b>	Tray cannot be baked
<b>Tray capacity</b>	20 converters / tray
<b>Box capacity</b>	60 products (3 full trays/box)
<b>Weight</b>	48 g empty tray, 1690 g full tray

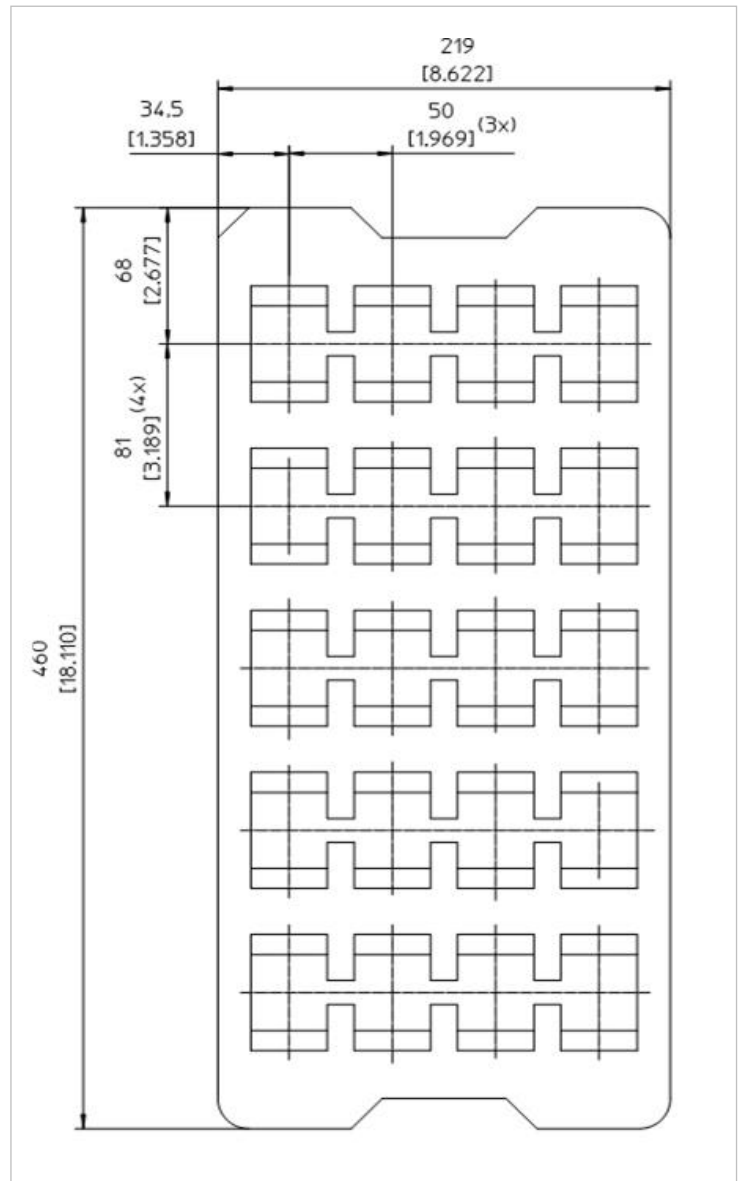

Example PE foam tray

## Part 6: Revision history

### Revision table

Revision number	revision information	date	responsible
Rev. A	First edition	2023-04-19	JIDMWANG

© Flex Power Modules 2023

The information and specifications in this technical specification is believed to be correct at the time of publication. However, no liability is accepted for inaccuracies, printing errors or for any consequences thereof. Flex reserves the right to change the contents of this technical specification at any time without prior notice.