

PKB 4513 Direct Converters
Input 48 V, Output 4 A/48 W

EN/LZT 146 407 R4A November 2017

© Flex

Key Features

- Industry standard Eighth-brick
58.4 x 22.7 x 8.73 mm (2.30 x 0.894 x 0.34 in.)
- Optimized for cold wall thermal management with Gap filler.
- High efficiency, typ. 91.6 % at full load
- 2250 Vdc input to output isolation
- Meets isolation requirements equivalent to basic insulation according to IEC/EN/UL 60950
- More than 1.6 million hours predicted MTBF at +40°C ambient temperature

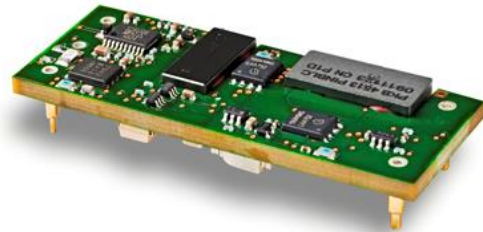

General Characteristics

- Input under voltage protection
- Over temperature protection
- Output short-circuit protection
- Remote control
- Highly automated manufacturing ensures quality
- ISO 9001/14001 certified supplier

Safety Approvals



Design for Environment



Meets requirements in high-temperature lead-free soldering processes.

Contents

Ordering Information	2
General Information	2
Safety Specification	3
Absolute Maximum Ratings	4
Electrical Specification	
12V, 4A / 48W	PKB4513PINBLC..... 5
12V, 4A / 48W, Vin: 30-60V	PKB4513PINBOVLC..... 9
EMC Specification	13
Operating Information	14
Thermal Consideration	15
Connections	15
Mechanical Information	16
Soldering Information	17
Delivery Information	17
Product Qualification Specification	18

PKB 4513 Direct Converters
Input 48 V, Output 4 A/48 W

EN/LZT 146 407 R4A November 2017

© Flex

Ordering Information

Product program	Output
PKB4513PINB	12 V, 4 A / 48 W

Product number and Packaging

PKB 4513PINB n ₁ n ₂ n ₃			
Options	n ₁	n ₂	n ₃
Input voltage	o		
Lead length		o	
Delivery package information			o

Options	Description
n ₁	36-60V* OV 30-60V
n ₂	LC 2.79 mm*
n ₃	Tray

Example a extend input voltage range, negative logic, short pin product with tray packaging would be PKB4513PINBOVLC/B.

* Standard variant (i.e. no option selected).

General Information

Reliability

The Mean Time Between Failure (MTBF) is calculated at full output power and an operating ambient temperature (T_A) of +40°C, which is a typical condition in Information and Communication Technology (ICT) equipment. Different methods could be used to calculate the predicted MTBF and failure rate which may give different results. Flex currently uses Telcordia SR332.

Predicted MTBF for the series is:

- 1.6 million hours according to Telcordia SR332, issue 1, Black box technique.

Telcordia SR332 is a commonly used standard method intended for reliability calculations in ICT equipment. The parts count procedure used in this method was originally modelled on the methods from MIL-HDBK-217F, Reliability Predictions of Electronic Equipment. It assumes that no reliability data is available on the actual units and devices for which the predictions are to be made, i.e. all predictions are based on generic reliability parameters.

Compatibility with RoHS requirements

The products are compatible with the relevant clauses and requirements of the RoHS directive 2002/95/EC and have a maximum concentration value of 0.1% by weight in homogeneous materials for lead, mercury, hexavalent chromium, PBB and PBDE and of 0.01% by weight in homogeneous materials for cadmium.

Exemptions in the RoHS directive utilized in Flex products include:

- Lead in high melting temperature type solder (used to solder the die in semiconductor packages)
- Lead in glass of electronics components and in electronic ceramic parts (e.g. fill material in chip resistors)
- Lead as an alloying element in copper alloy containing up to 4% lead by weight (used in connection pins made of Brass)

Quality Statement

The products are designed and manufactured in an industrial environment where quality systems and methods like ISO 9000, 6σ (sigma), and SPC are intensively in use to boost the continuous improvements strategy. Infant mortality or early failures in the products are screened out and they are subjected to an ATE-based final test. Conservative design rules, design reviews and product qualifications, plus the high competence of an engaged work force, contribute to the high quality of our products.

Warranty

Warranty period and conditions are defined in Flex General Terms and Conditions of Sale.

Limitation of Liability

Flex does not make any other warranties, expressed or implied including any warranty of merchantability or fitness for a particular purpose (including, but not limited to, use in life support applications, where malfunctions of product can cause injury to a person's health or life).

© Flex 2011

The information and specifications in this technical specification is believed to be correct at the time of publication. However, no liability is accepted for inaccuracies, printing errors or for any consequences thereof. Flex reserves the right to change the contents of this technical specification at any time without prior notice.

PKB 4513 Direct Converters Input 48 V, Output 4 A/48 W	EN/LZT 146 407 R4A November 2017
	© Flex

Safety Specification

General information

Flex DC/DC converters and DC/DC regulators are designed in accordance with safety standards IEC/EN/UL60950, *Safety of Information Technology Equipment*.

IEC/EN/UL60950 contains requirements to prevent injury or damage due to the following hazards:

- Electrical shock
- Energy hazards
- Fire
- Mechanical and heat hazards
- Radiation hazards
- Chemical hazards

On-board DC-DC converters and DC/DC regulators are defined as component power supplies. As components they cannot fully comply with the provisions of any Safety requirements without "Conditions of Acceptability". Clearance between conductors and between conductive parts of the component power supply and conductors on the board in the final product must meet the applicable Safety requirements. Certain conditions of acceptability apply for component power supplies with limited stand-off (see Mechanical Information for further information). It is the responsibility of the installer to ensure that the final product housing these components complies with the requirements of all applicable Safety standards and Directives for the final product.

Component power supplies for general use should comply with the requirements in IEC60950, EN60950 and UL60950 "*Safety of information technology equipment*".

There are other more product related standards, e.g. IEEE802.3af "Ethernet LAN/MAN Data terminal equipment power", and ETS300132-2 "Power supply interface at the input to telecommunications equipment; part 2: DC", but all of these standards are based on IEC/EN/UL60950 with regards to safety.

Flex DC/DC converters and DC/DC regulators are UL60950 recognized and certified in accordance with EN60950.

The flammability rating for all construction parts of the products meets requirements for V-0 class material according to IEC 60695-11-10.

The products should be installed in the end-use equipment, in accordance with the requirements of the ultimate application. Normally the output of the DC/DC converter is considered as SELV (Safety Extra Low Voltage) and the input source must be isolated by minimum Double or Reinforced Insulation from the primary circuit (AC mains) in

accordance with IEC/EN/UL60950.

Isolated DC/DC converters

It is recommended that a slow blow fuse with a rating twice the maximum input current per selected product be used at the input of each DC/DC converter. If an input filter is used in the circuit the fuse should be placed in front of the input filter.

In the rare event of a component problem in the input filter or in the DC/DC converter that imposes a short circuit on the input source, this fuse will provide the following functions:

- Isolate the faulty DC/DC converter from the input power source so as not to affect the operation of other parts of the system.
- Protect the distribution wiring from excessive current and power loss thus preventing hazardous overheating.

The galvanic isolation is verified in an electric strength test. The test voltage (V_{iso}) between input and output is 1500 Vdc or 2250 Vdc for 60 seconds (refer to product specification).

Leakage current is less than 1 μ A at nominal input voltage.

48 and 60 V DC systems

If the input voltage to the DC/DC converter is 75 Vdc or less, then the output remains SELV (Safety Extra Low Voltage) under normal and abnormal operating conditions.

Single fault testing in the input power supply circuit should be performed with the DC/DC converter connected to demonstrate that the input voltage does not exceed 75 Vdc.

If the input power source circuit is a DC power system, the source may be treated as a TNV2 circuit and testing has demonstrated compliance with SELV limits and isolation requirements equivalent to Basic Insulation in accordance with IEC/EN/UL60950.

PKB 4513 Direct Converters
Input 48 V, Output 4 A/48 W

EN/LZT 146 407 R4A November 2017

© Flex

Absolute Maximum Ratings

Characteristics		min	typ	max	Unit
T_{P1}	Operating Temperature (see Thermal Consideration section)	-40		+120	°C
T_S	Storage temperature	-55		+125	°C
V_I	Input voltage	-0.5		+80	V
V_{iso}	Isolation voltage (input to output test voltage)			2250	Vdc
V_{tr}	Input voltage transient (t_p 100 ms)			100	V
V_{RC}	Remote Control pin voltage (see Operating Information section)	Positive logic option		6	V
		Negative logic option	-0.5	40	V

Stress in excess of Absolute Maximum Ratings may cause permanent damage. Absolute Maximum Ratings, sometimes referred to as no destruction limits, are normally tested with one parameter at a time exceeding the limits in the Electrical Specification. If exposed to stress above these limits, function and performance may degrade in an unspecified manner.

Fundamental Circuit Diagram

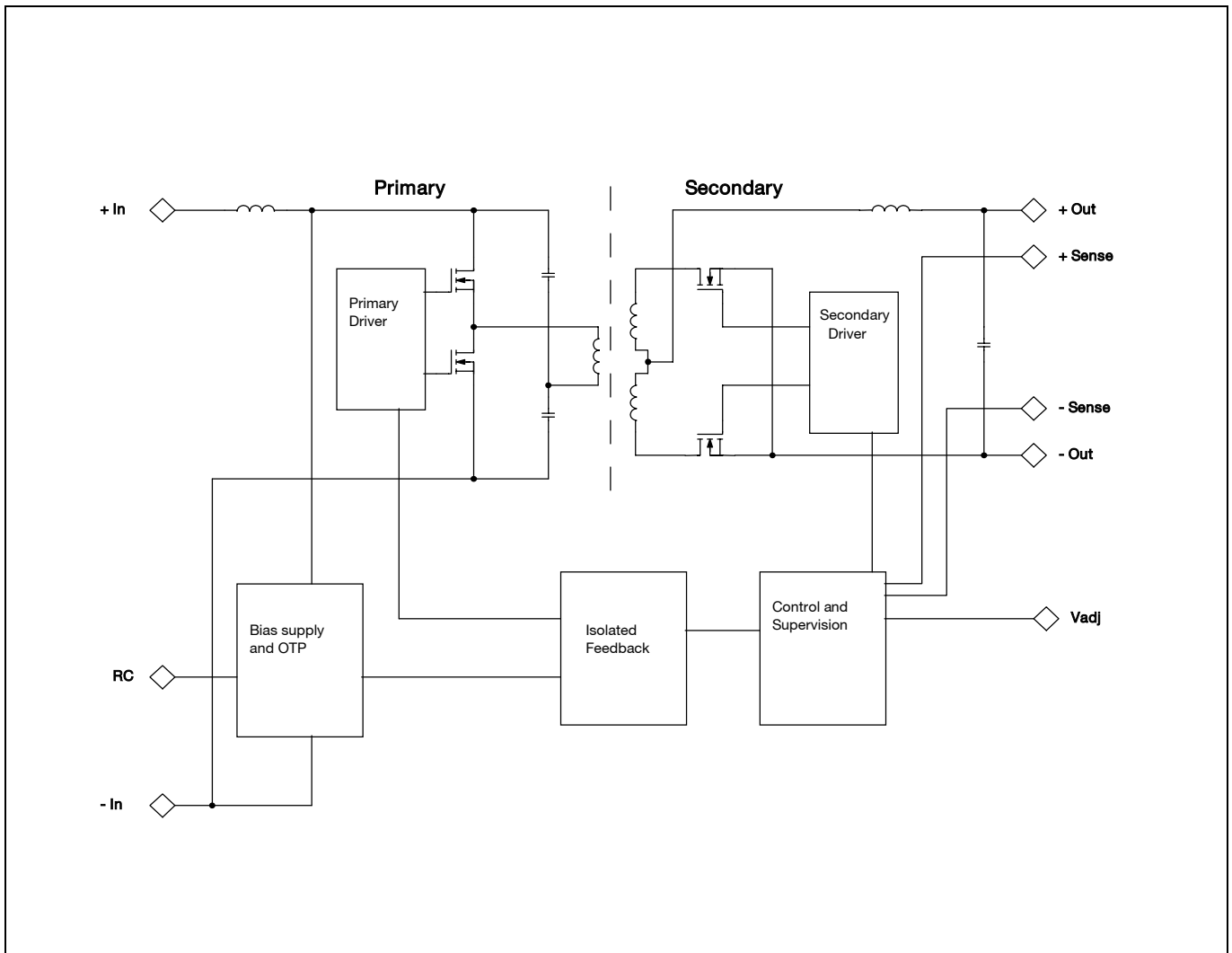

PKB 4513 Direct Converters
 Input 48 V, Output 4 A/48 W

EN/LZT 146 407 R4A November 2017

© Flex

12V, 4A /48W Electrical Specification
PKB 4513 PINBLC
 $T_{P1} = -40$ to $+95^{\circ}\text{C}$, $V_I = 36$ to 60 V, unless otherwise specified under Conditions.

 Typical values given at: $T_{P1} = +25^{\circ}\text{C}$, $V_I = 48$ V, $I_O = \text{max } I_O$, unless otherwise specified under Conditions.

See Operating Information section for selection of capacitor types.

Characteristics		Conditions	min	typ	max	Unit
V_I	Input voltage range		36		60	V
V_{loff}	Turn-off input voltage	Decreasing input voltage	30	31	33	V
V_{lon}	Turn-on input voltage	Increasing input voltage	33.5	34	34.5	V
Hyst	Input turn-on/off hysteresis		2.0	3		V
C_I	Internal input capacitance			3.35		μF
P_O	Output power		0		48	W
η	Efficiency	50 % of max I_O		89		%
		max I_O		91.8		
		50 % of max I_O , $V_I = 53$ V		88.3		
		max I_O , $V_I = 53$ V		91.5		
P_d	Power Dissipation	max I_O		4.3	5.7	W
P_{li}	Input idling power	$I_O = 0$ A, $V_I = 48$ V		2.3		W
P_{RC}	Input standby power	$V_I = 48$ V (turned off with RC)		0.1		W
f_s	Switching frequency	10-100 % of max I_O	230	250	270	kHz

V_{oi}	Output voltage initial setting and accuracy	$T_{P1} = +25^{\circ}\text{C}$, $V_I = 48$ V, $I_O = 4$ A	11.8	12.0	12.25	V
V_O	Output voltage tolerance band	10-100 % of max I_O	11.58		12.42	V
	Idling voltage	$I_O = 0$ A	11.58		12.42	V
	Line regulation	max I_O		0.6	3	mV
	Load regulation	$V_I = 48$ V, 10-100 % of max I_O		0.8	4	mV
	Temperature regulation			50	200	mV
V_{tr}	Load transient voltage deviation	$V_I = 48$ V, Load step 25-75-25 % of max I_O , $di/dt = 0.1$ A/ μs see Note 1		± 130	± 200	mV
t_{tr}	Load transient recovery time			40	60	μs
t_r	Ramp-up time (from 10-90 % of V_{oi})	10-100 % of max I_O	8	13	19	ms
t_s	Start-up time (from V_I connection to 90 % of V_{oi})		10	20	40	ms
t_f	V_I shut-down fall time (from V_I off to 10 % of V_O)	max I_O		0.3		ms
		$I_O = 0.4$ A		3		ms
t_{RC}	RC start-up time	max I_O	10	20	30	ms
	RC shut-down fall time (from RC off to 10 % of V_O)	max I_O		0.3		ms
		$I_O = 0.4$ A		2.8		ms
I_O	Output current		0.4		4	A
I_{lim}	Current limit threshold	$T_{P1} < \text{max } T_{P1}$	4.9	6.3	7.4	A
I_{sc}	Short circuit current	$T_{P1} = 25^{\circ}\text{C}$, see Note 2		9.3	10	A
C_{out}	Recommended Capacitive Load	$T_{P1} = 25^{\circ}\text{C}$,	0		3000	μF
V_{Oac}	Output ripple & noise	See ripple & noise section, max I_O , V_{oi}		14	50	mVp-p

 Note 1: C_{out} used at load transient test is 470 μF low-ESR capacitor.

Note 2: See Operating Information section.

PKB 4513 Direct Converters
Input 48 V, Output 4 A/48 W

EN/LZT 146 407 R4A November 2017

© Flex

12V, 4A /48W Typical Characteristics

PKB 4513 PINBLC

Efficiency

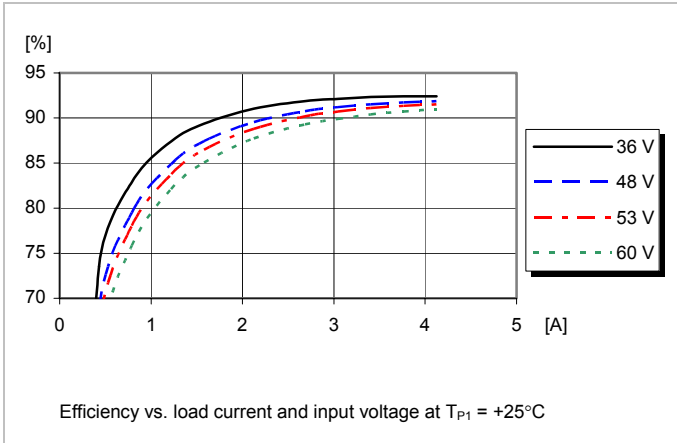

Power Dissipation

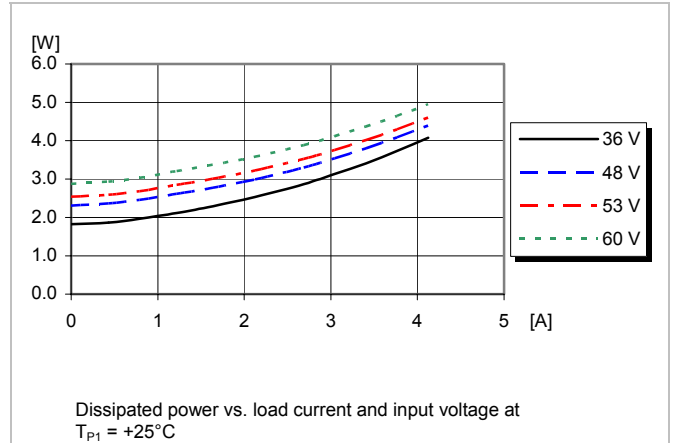

Output Characteristics

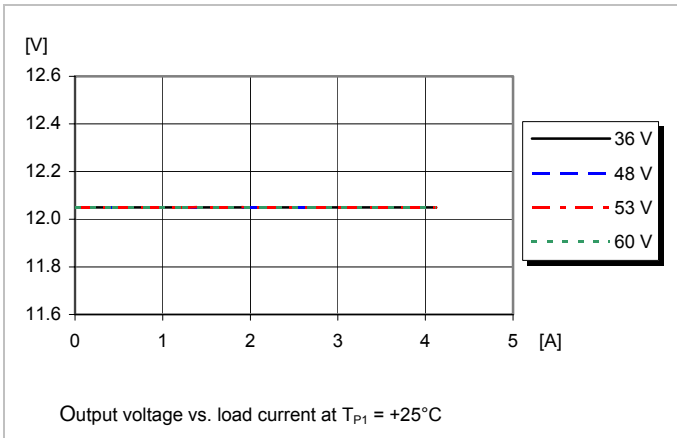

Current Limit Characteristics

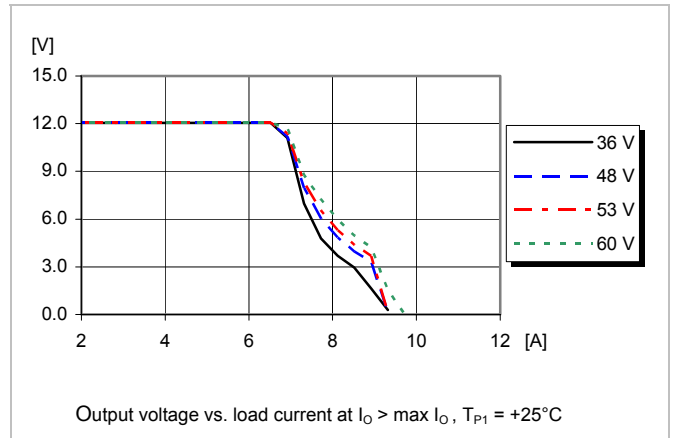

PKB 4513 Direct Converters
Input 48 V, Output 4 A/48 W

EN/LZT 146 407 R4A November 2017

© Flex

12V, 4A /48W Typical Characteristics

PKB 4513 PINBLC

Start-up

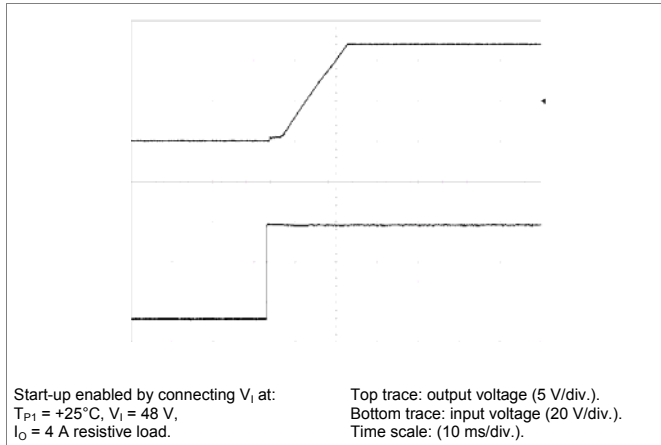

Shut-down

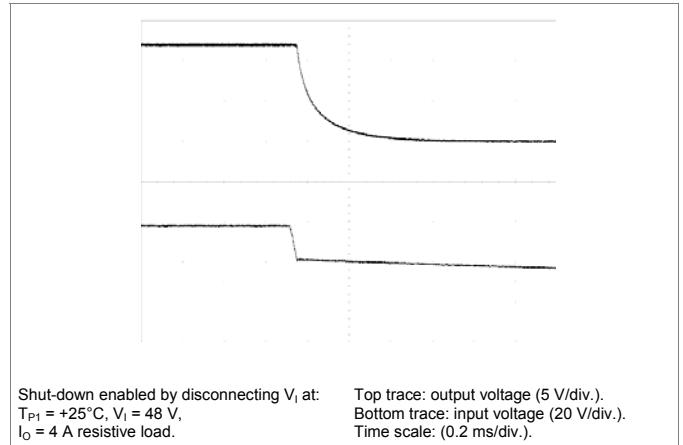

Output Ripple & Noise

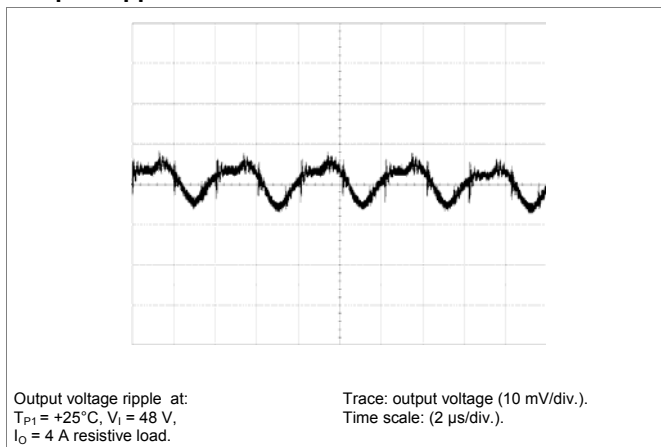

Output Load Transient Response

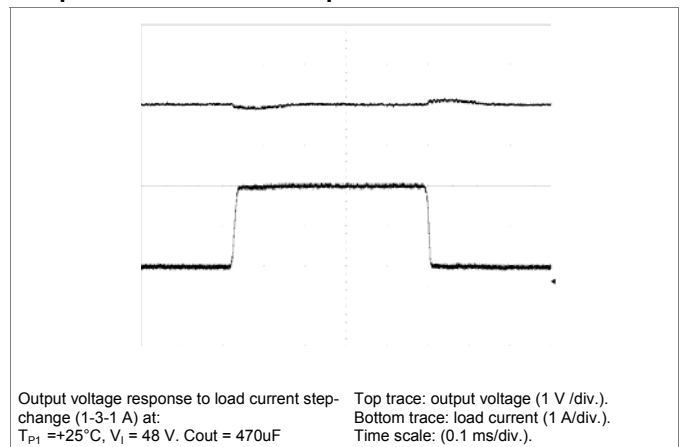

PKB 4513 Direct Converters
 Input 48 V, Output 4 A/48 W

EN/LZT 146 407 R4A November 2017

© Flex

12V, 4A /48W Typical Characteristics

PKB 4513 PINBLC

Output Current Derating – Open frame

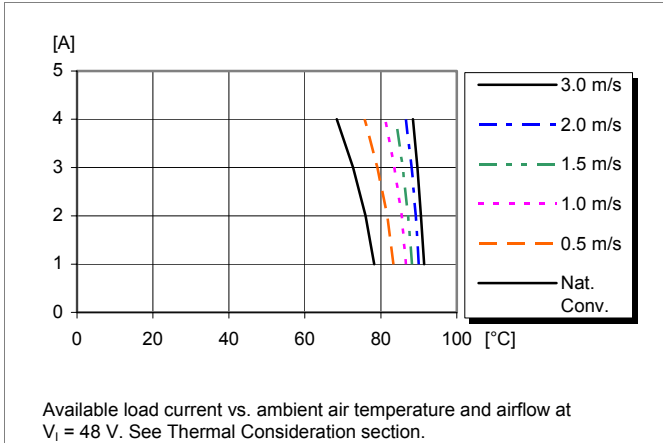

PKB 4513 Direct Converters
 Input 48 V, Output 4 A/48 W

EN/LZT 146 407 R4A November 2017

© Flex

12V, 4A /48W Electrical Specification
PKB 4513 PINBOVLC
 $T_{P1} = -40$ to $+95^{\circ}\text{C}$, $V_I = 30$ to 60 V, unless otherwise specified under Conditions.

 Typical values given at: $T_{P1} = +25^{\circ}\text{C}$, $V_I = 48$ V, $I_O = \text{max } I_O$, unless otherwise specified under Conditions.

See Operating Information section for selection of capacitor types.

Characteristics		Conditions	min	typ	max	Unit
V_I	Input voltage range		30		60	V
V_{loff}	Turn-off input voltage	Decreasing input voltage	24.8	25.8	26.8	V
V_{lon}	Turn-on input voltage	Increasing input voltage	28	28.5	29	V
Hyst	Input turn-on/off hysteresis		2.0	3		V
C_I	Internal input capacitance			3.35		μF
P_O	Output power		0		48	W
η	Efficiency	50 % of max I_O		87.9		%
		max I_O		91.0		
		50 % of max I_O , $V_I = 53$ V		87		
		max I_O , $V_I = 53$ V		90.4		
P_d	Power Dissipation	max I_O		4.8	6.5	W
P_{li}	Input idling power	$I_O = 0$ A, $V_I = 48$ V		2.6		W
P_{RC}	Input standby power	$V_I = 48$ V (turned off with RC)		0.1		W
f_s	Switching frequency	10-100 % of max I_O	230	250	270	kHz

V_{oi}	Output voltage initial setting and accuracy	$T_{P1} = +25^{\circ}\text{C}$, $V_I = 48$ V, $I_O = 4$ A	11.8	12.0	12.25	V
V_O	Output voltage tolerance band	10-100 % of max I_O	11.58		12.42	V
	Idling voltage	$I_O = 0$ A	11.58		12.42	V
	Line regulation	max I_O		3	6	mV
	Load regulation	$V_I = 48$ V, 10-100 % of max I_O		1	6	mV
	Temperature regulation			50	200	mV
V_{tr}	Load transient voltage deviation	$V_I = 48$ V, Load step 25-75-25 % of max I_O , $di/dt = 0.1$ A/ μs see Note 1		± 160	± 250	mV
t_{tr}	Load transient recovery time			100		μs
t_r	Ramp-up time (from 10-90 % of V_{oi})	10-100 % of max I_O	10	14	20	ms
t_s	Start-up time (from V_I connection to 90 % of V_{oi})		15	22	31	ms
t_f	V_I shut-down fall time (from V_I off to 10 % of V_O)	max I_O		0.3		ms
		$I_O = 0.4$ A		3		ms
t_{RC}	RC start-up time	max I_O		18		ms
	RC shut-down fall time (from RC off to 10 % of V_O)	max I_O		0.3		ms
		$I_O = 0.4$ A		2.6		ms
I_O	Output current		0.4		4	A
I_{lim}	Current limit threshold	$T_{P1} < \text{max } T_{P1}$	4.6	5.2	7.4	A
I_{sc}	Short circuit current	$T_{P1} = 25^{\circ}\text{C}$, see Note 2		7.3	8	A
C_{out}	Recommended Capacitive Load	$T_{P1} = 25^{\circ}\text{C}$,	0		3000	μF
V_{Oac}	Output ripple & noise	See ripple & noise section, max I_O , V_{oi}		24	50	mVp-p

 Note 1: C_{out} used at load transient test is 470 μF low-ESR capacitor.

Note 2: See Operating Information section.

PKB 4513 Direct Converters
Input 48 V, Output 4 A/48 W

EN/LZT 146 407 R4A November 2017

© Flex

12V, 4A /48W Typical Characteristics

PKB 4513 PINBOVLC

Efficiency

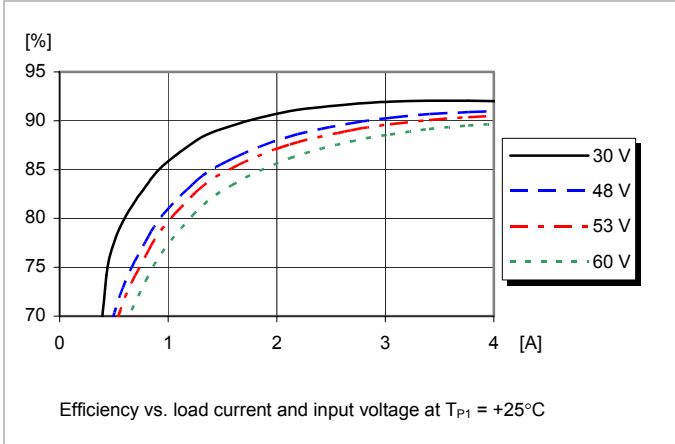

Power Dissipation

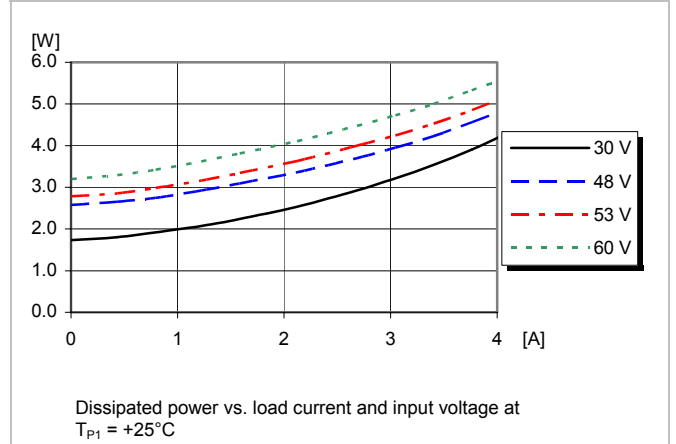

Output Characteristics

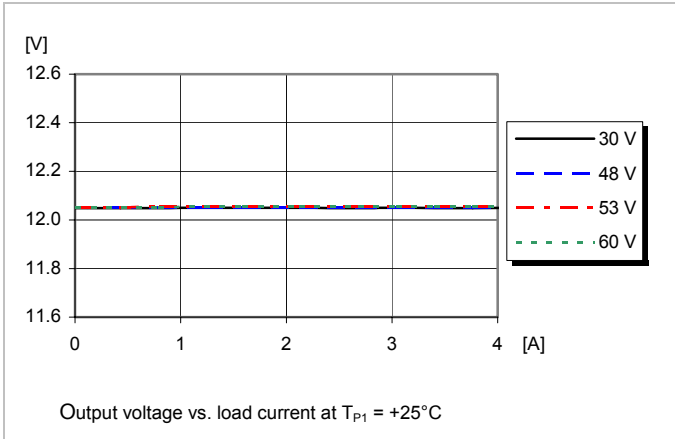

Current Limit Characteristics

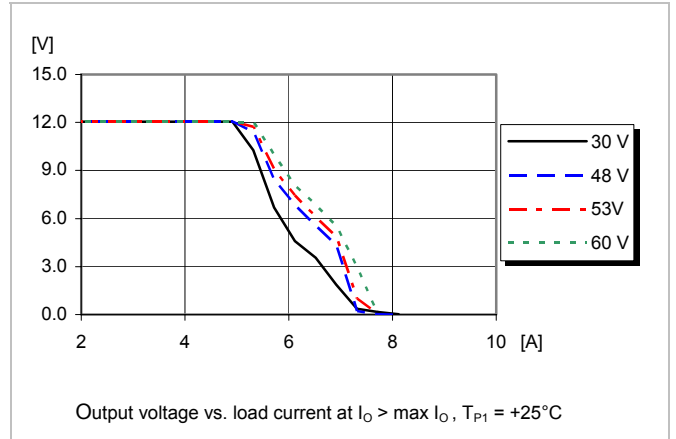

PKB 4513 Direct Converters
Input 48 V, Output 4 A/48 W

EN/LZT 146 407 R4A November 2017

© Flex

12V, 4A /48W Typical Characteristics

PKB 4513 PINBOVLC

Start-up

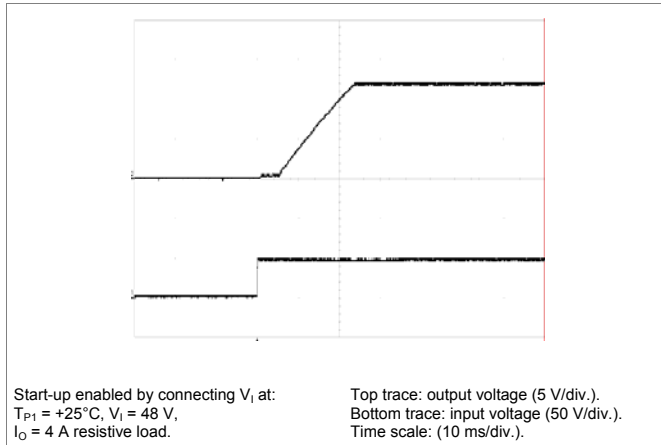

Shut-down

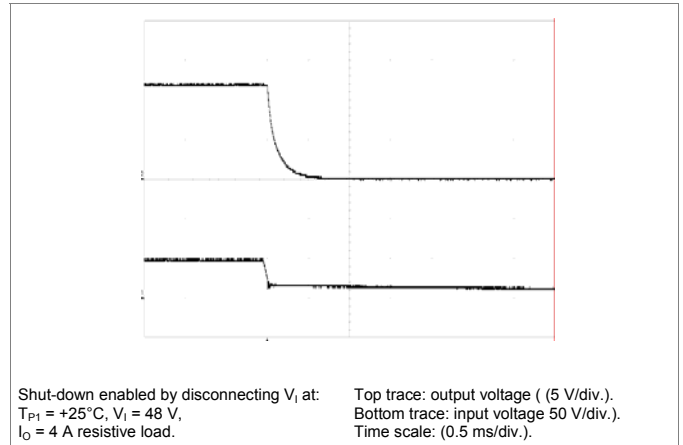

Output Ripple & Noise

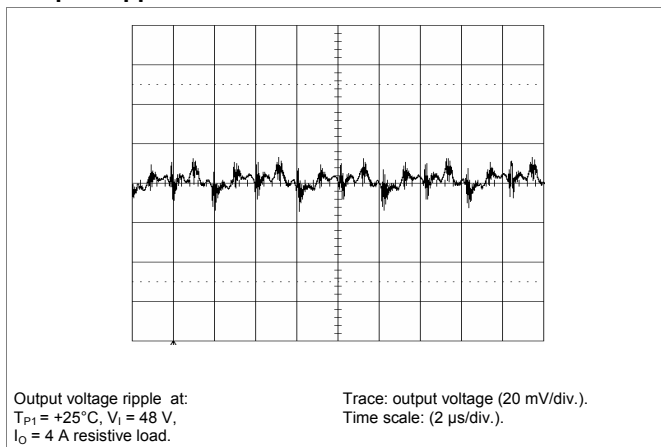

Output Load Transient Response

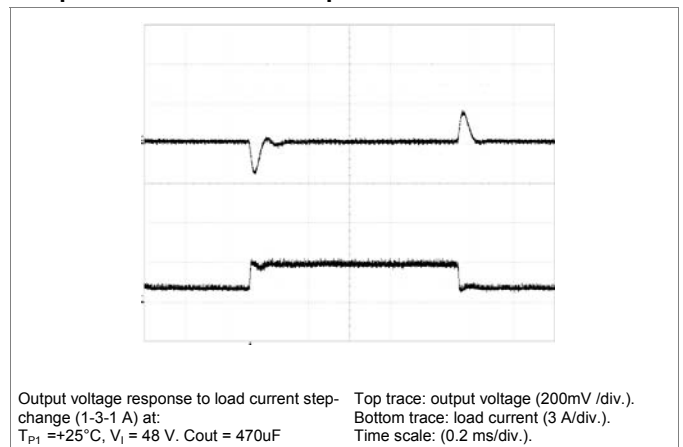

PKB 4513 Direct Converters
 Input 48 V, Output 4 A/48 W

EN/LZT 146 407 R4A November 2017

© Flex

12V, 4A /48W Typical Characteristics

PKB 4513 PINBOVLC

Output Current Derating – Open frame

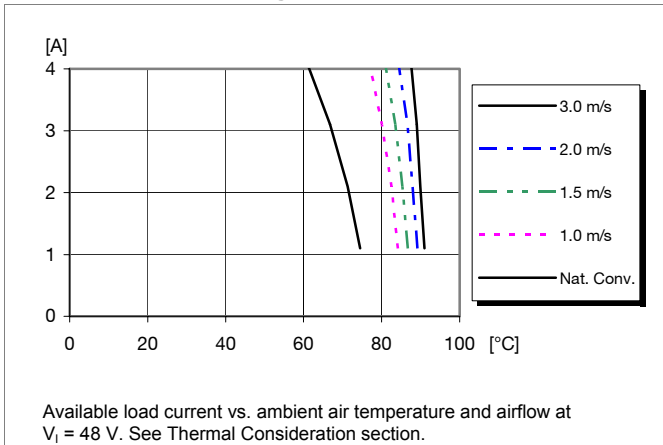

PKB 4513 Direct Converters
Input 48 V, Output 4 A/48 W

EN/LZT 146 407 R4A November 2017

© Flex

EMC Specification

Conducted EMI measured according to EN55022, CISPR 22 and FCC part 15J (see test set-up). See Design Note 009 for further information. The fundamental switching frequency is 250 kHz for PKB 4513 PINBOVLC @ $V_I = 48\text{ V}$, max I_O .

Conducted EMI Input terminal value (typ)

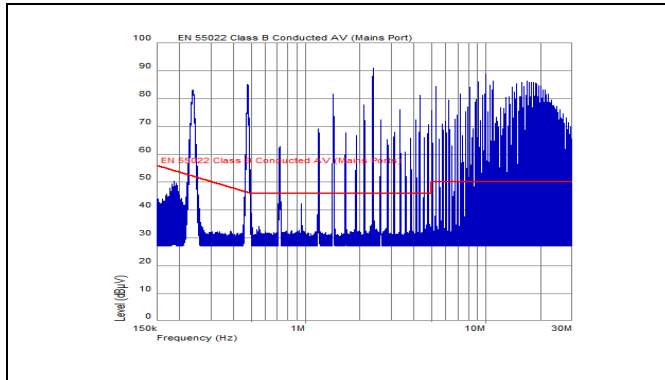

EMI without filter

External filter (class B)

Required external input filter in order to meet class B in EN 55022, CISPR 22 and FCC part 15J.

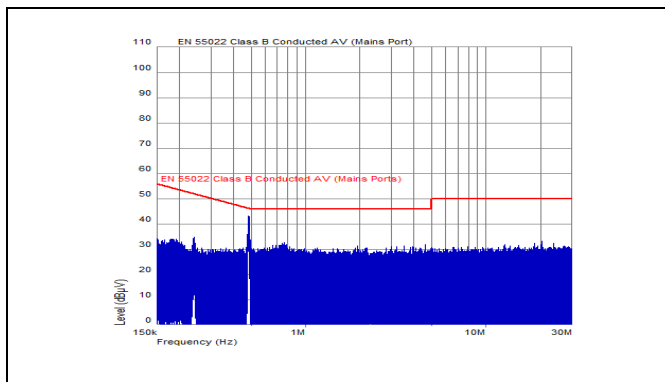
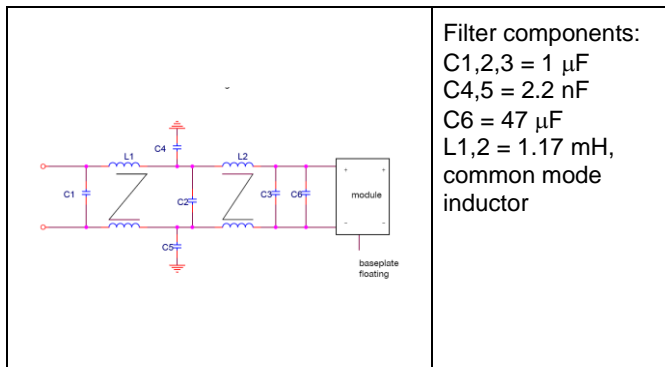

EMI with filter

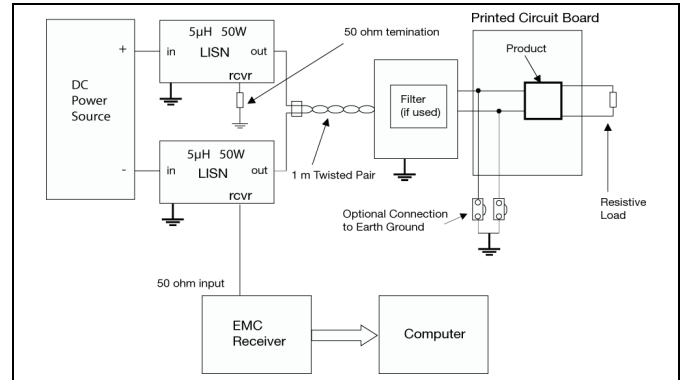

Test set-up

Layout recommendations

The radiated EMI performance of the Product will depend on the PCB layout and ground layer design. It is also important to consider the stand-off of the product. If a ground layer is used, it should be connected to the output of the product and the equipment ground or chassis.

A ground layer will increase the stray capacitance in the PCB and improve the high frequency EMC performance.

Output ripple and noise

Output ripple and noise measured according to figure below. See Design Note 022 for detailed information.

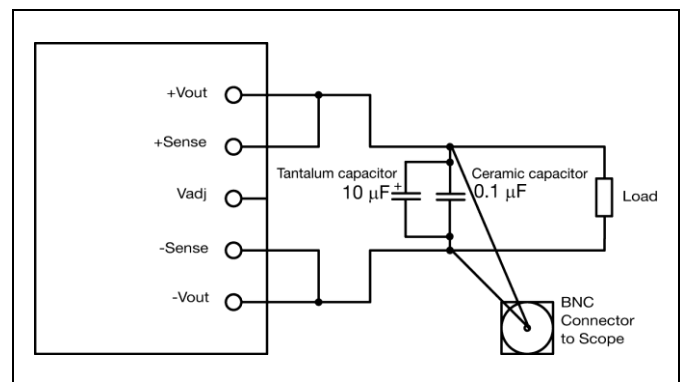

Output ripple and noise test setup

PKB 4513 Direct Converters Input 48 V, Output 4 A/48 W	EN/LZT 146 407 R4A November 2017
	© Flex

Operating information

Input Voltage

The input voltage range 30 to 60Vdc meets the requirements of the European Telecom Standard ETS 300 132-2 for normal input voltage range in-48 Vdc systems.

At input voltages exceeding 60 V, the power loss will be higher than at normal input voltage and T_{P1} must be limited to absolute max +110°C. The absolute maximum continuous input voltage is 80 Vdc.

Turn-off Input Voltage

The DC/DC converters monitor the input voltage and will turn on and turn off at predetermined levels.

The minimum hysteresis between turn on and turn off input voltage is 2V.

Remote Control (RC)

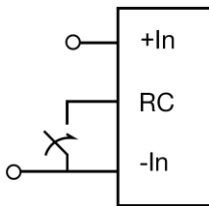

The products are fitted with a remote control function referenced to the primary negative input connection (- In), with negative and positive logic options available. The RC function allows the converter to be turned on/off by an external device like a semiconductor or mechanical switch.

The maximum required sink current is 1 mA. When the RC pin is left open, the voltage generated on the RC pin is 6 V. The second option is "positive logic" remote control, which can be ordered by adding the suffix "P" to the end of the part number. The converter will turn on when the input voltage is applied with the RC pin open. Turn off is achieved by connecting the RC pin to the - In. To ensure safe turn off the voltage difference between RC pin and the - In pin shall be less than 1V. The converter will restart automatically when this connection is opened.

See Design Note 021 for detailed information.

Input and Output Impedance

The impedance of both the input source and the load will interact with the impedance of the DC/DC converter. It is important that the input source has low characteristic impedance. The converters are designed for stable operation without external capacitors connected to the input or output. The performance in some applications can be enhanced by addition of external capacitance as described under External Decoupling Capacitors. If the input voltage source contains significant inductance, the addition of a 100 μ F capacitor across the input of the converter will ensure stable operation. The capacitor is not required when powering the DC/DC converter from an input source with an inductance below 10 μ H.

External Decoupling Capacitors

When powering loads with significant dynamic current requirements, the voltage regulation at the point of load can be improved by addition of decoupling capacitors at the load. The most effective technique is to locate low ESR ceramic and electrolytic capacitors as close to the load as possible, using several parallel capacitors to lower the effective ESR. The ceramic capacitors will handle high-frequency dynamic load changes while the electrolytic capacitors are used to handle low frequency dynamic load changes. Ceramic capacitors will also reduce any high frequency noise at the load.

It is equally important to use low resistance and low inductance PCB layouts and cabling.

External decoupling capacitors will become part of the control loop of the DC/DC converter and may affect the stability margins. An 470uF lower ESR capacitor should be added at output to get the load transient performance specified in the datasheet. The module can work with 0-3000uF low ESR capacitor at output in 25°C and 95°C, but it can only handle 0uF low ESR capacitor at output in -40°C. The ESR of the capacitors is a very important parameter. Power Modules guarantee stable operation with a verified ESR value of >10 m Ω across the output connections. For further information please contact your local Flex Power Modules representative.

Parallel Operation

Two converters may be paralleled for redundancy if the total power is equal or less than P_O max. It is not recommended to parallel the converters without using external current sharing circuits.

See Design Note 006 for detailed information.

Over Temperature Protection (OTP)

The converters are protected from thermal overload by the control IC.

When T_{P1} as defined in thermal consideration section exceeds 135°C the converter will shut down. The DC/DC converter will make continuous attempts to start up (non-latching mode) and resume normal operation automatically when the temperature has dropped about 15°C below the temperature threshold.

Over Current Protection (OCP)

The converters include current limiting circuitry for protection at continuous overload.

The output voltage will decrease towards zero for output currents in excess of max output current (max I_o). The converter will resume normal operation after removal of the overload. The load distribution should be designed for the maximum output short circuit current specified.

PKB 4513 Direct Converters
Input 48 V, Output 4 A/48 W

EN/LZT 146 407 R4A November 2017

© Flex

Thermal Consideration

General

The converters are designed to operate in different thermal environments and sufficient cooling must be provided to ensure reliable operation.

Cooling is achieved mainly by conduction, from the pins to the host board, and convection, which is dependant on the airflow across the converter. Increased airflow enhances the cooling of the converter.

The Output Current Derating graph found in the Output section for each model provides the available output current vs. ambient air temperature and air velocity at $V_{in} = 48 V$.

The DC/DC converter is tested on a 254 x 254 mm, 35 μm (1 oz), 8-layer test board mounted vertically in a wind tunnel with a cross-section of 305 x 305 mm.

Proper cooling of the DC/DC converter can be verified by measuring the temperature at positions P1, P2, P3, P4, P5 and P6. The temperature at these positions should not exceed the max values provided in the table below.

Note that the max value is the absolute maximum rating (non destruction) and that the electrical Output data is guaranteed up to $T_{P1} = +95^{\circ}C$.

See Design Note 019 for further information.

Connections

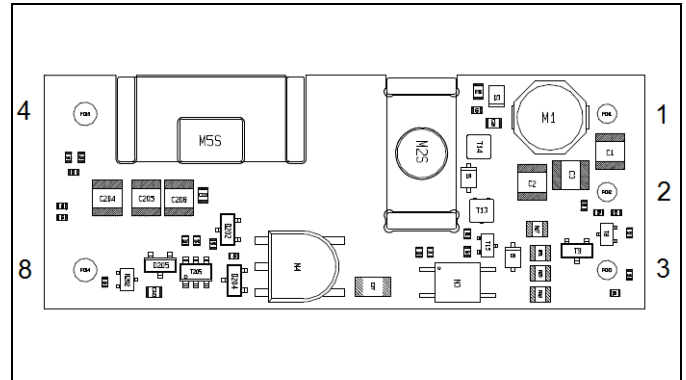

Pin	Designation	Function
1	+In	Positive input
2	RC	Remote control
3	-In	Negative input
4	+Out	Positive output
8	-Out	Negative output

Position	Description	Temp. limit
P1	Reference Point, PCB	110°C
P2	MOSFET, T203	120°C
P3	MOSFET, T202	120°C
P4	IC, N1	120°C
P5	Optocoupler, N3	95°C
P6	Ferrite core, M2	130°C

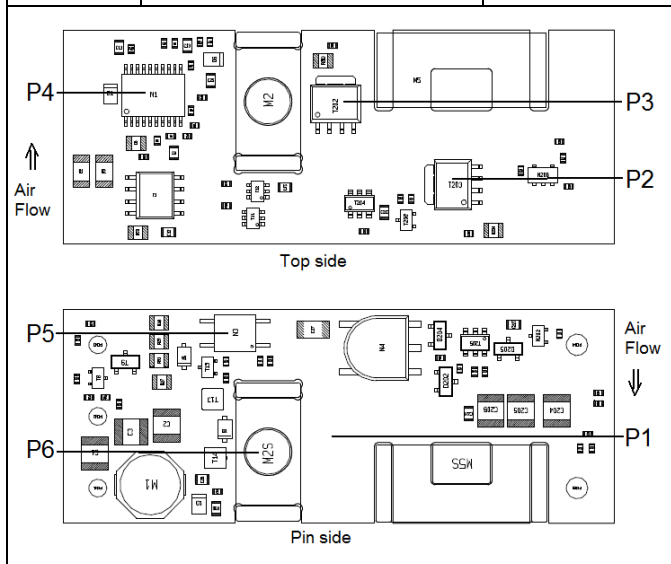

PKB 4513 Direct Converters
Input 48 V, Output 4 A/48 W

EN/LZT 146 407 R4A November 2017

© Flex

Mechanical Information- Through hole mount version

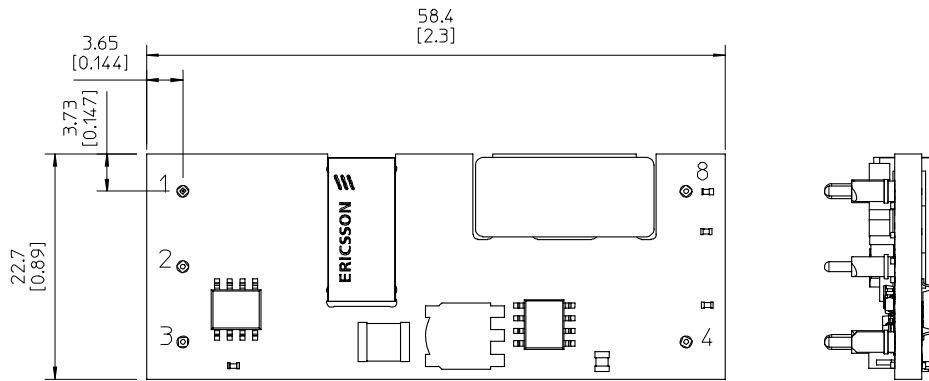
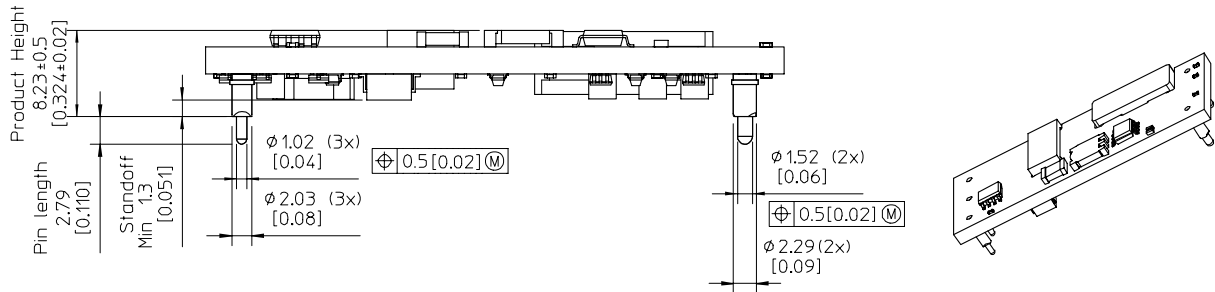

RECOMMENDED FOOTPRINT

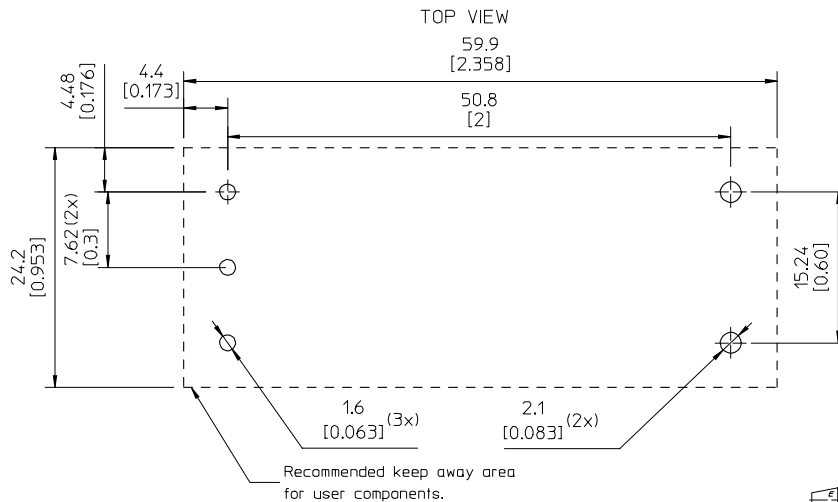

Notes: 1. Height difference (between dissipating components, magnets and MOSFETs on topside) is Max = 1.0 mm, Typical = 0.60 mm

Pins:
Material, pins 1-3: Brass
Material, pins 4,8: copper alloy
Plating: 0.1 μ m Au over 2 μ m Ni

Weight: typical 21 g

All dimensions in mm[inch].
Tolerance unless specified
x.x mm \pm 0.5mm [0.02]
x.xx mm \pm 0.25 mm [0.01]
(not applied on footprint or typical values)



PKB 4513 Direct Converters
Input 48 V, Output 4 A/48 W

EN/LZT 146 407 R4A November 2017

© Flex

Soldering Information - Hole Mounting

The hole mounted product is intended for plated through hole mounting by wave or manual soldering. The pin temperature is specified to maximum to 270°C for maximum 10 seconds.

A maximum preheat rate of 4°C/s and maximum preheat temperature of 150°C is suggested. When soldering by hand, care should be taken to avoid direct contact between the hot soldering iron tip and the pins for more than a few seconds in order to prevent overheating.

A no-clean flux is recommended to avoid entrapment of cleaning fluids in cavities inside the product or between the product and the host board. The cleaning residues may affect long time reliability and isolation voltage.

Delivery Package Information

The products are delivered in antistatic injection molded trays
(*Figure 1 Jedec design guide 4.10D standard tray*)

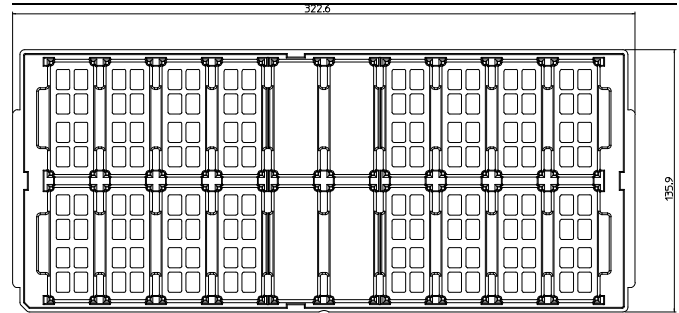

Figure 1 Jedec design guide 4.10D standard tray

Tray Specifications	
Material	Antistatic PPE
Surface resistance	$10^5 < \text{Ohm/square} < 10^{11}$
Bakability	The trays can be baked at maximum 125 °C for 48 hours
Tray thickness	20.35 mm [0.801 inch]
Box capacity	100 products (5 full trays/box)
Tray weight	180 g empty, 600 g full tray

PKB 4513 Direct Converters
 Input 48 V, Output 4 A/48 W

EN/LZT 146 407 R4A November 2017

© Flex

Product Qualification Specification

Characteristics			
External visual inspection	IPC-A-610		
Change of temperature (Temperature cycling)	IEC 60068-2-14 Na	Temperature range Number of cycles Dwell/transfer time	-40 to 100°C 1000 15 min/0-1 min
Cold (in operation)	IEC 60068-2-1 Ad	Temperature T _A Duration	-45°C 72 h
Damp heat	IEC 60068-2-67 Cy	Temperature Humidity Duration	85°C 85 % RH 1000 hours
Dry heat	IEC 60068-2-2 Bd	Temperature Duration	125°C 1000 h
Electrostatic discharge susceptibility	IEC 61340-3-1, JESD 22-A114 IEC 61340-3-2, JESD 22-A115	Human body model (HBM) Machine Model (MM)	Class 2, 2000 V Class 3, 200 V
Immersion in cleaning solvents	IEC 60068-2-45 XA, method 2	Water Glycol ether	55°C 35°C
Mechanical shock	IEC 60068-2-27 Ea	Peak acceleration Duration	100 g 6 ms
Moisture reflow sensitivity ¹	J-STD-020C	Level 1 (SnPb-eutectic) Level 3 (Pb Free)	225°C 260°C
Operational life test	MIL-STD-202G, method 108A	Duration	1000 h
Resistance to soldering heat ²	IEC 60068-2-20 Tb, method 1A	Solder temperature Duration	270°C 10-13 s
Robustness of terminations	IEC 60068-2-21 Test Ua1 IEC 60068-2-21 Test Ue1	Through hole mount products Surface mount products	All leads All leads
Solderability	IEC 60068-2-58 test Td ¹	Preconditioning Temperature, SnPb Eutectic Temperature, Pb-free	150°C dry bake 16 h 215°C 235°C
	IEC 60068-2-20 test Ta ²	Preconditioning Temperature, SnPb Eutectic Temperature, Pb-free	Steam ageing 235°C 245°C
Vibration, broad band random	IEC 60068-2-64 Fh, method 1	Frequency Spectral density Duration	10 to 500 Hz 0.07 g ² /Hz 10 min in each direction

Notes
¹ Only for products intended for reflow soldering (surface mount products)

² Only for products intended for wave soldering (plated through hole products)