

PKM 5000D PINB series Direct Converters
 Input 18-75 V, Output up to 11 A / 132 W

EN/LZT 146 426 R3A Oct. 2017

© Flex

Key Features

- Industry standard Quarter-brick. 57.9 x 36.8 x 9.35 mm (2.28 x 1.45 x 0.368 in)
- High efficiency, typ. 93.5% at 12 Vout half load
- 2250 Vdc input to output isolation
- Meets isolation requirements equivalent to basic insulation according to IEC/EN/UL 60950-1
- More than 3.3 million hours MTBF

General Characteristics

- Output over voltage protection
- Over temperature protection
- Output short-circuit protection
- Remote control
- Output voltage adjust function
- Highly automated manufacturing ensures quality
- ISO 9001/14001 certified supplier



Safety Approvals



Design for Environment



Meets requirements in high-temperature lead-free soldering processes.

Contents

Ordering Information	2
General Information	2
Safety Specification	3
Absolute Maximum Ratings	4
Electrical Specification	
12V, 11A / 132W	PKM 5113D PINB 5
EMC Specification	11
Operating Information	12
Thermal Consideration	13
Connections	15
Mechanical Information	16
Soldering Information	18
Delivery Information	18
Product Qualification Specification	19

PKM 5000D PINB series Direct Converters Input 18-75 V, Output up to 11 A / 132 W

EN/LZT 146 426 R3A Oct. 2017

© Flex

Ordering Information

Product program	Output
PKM 5113D	12 V, 11 A / 132 W

Product number and Packaging

PKM 5XXXX PI n ₁ n ₂ n ₃ n ₄ n ₅					
Options	n ₁	n ₂	n ₃	n ₄	n ₅
Mounting	o				
Remote Control logic		o			
Baseplate			o		
Stand-off height				o	
Lead length					o

Options	Description	
n ₁	PI	Through hole *
n ₂	P	Negative * Positive
n ₃	NB	Baseplate No baseplate *
n ₄	M	Standard stand-off * Increased stand-off height
n ₅	LA	5.30 mm *
	LB	3.69 mm
		4.57 mm

Example a through-hole mounted, positive logic, no base plate, short pin product with increased stand-off height would be PKM 5113DPIPMBMLB.

* Standard variant (i.e. no option selected).

General Information

Reliability

The failure rate (λ) and mean time between failures (MTBF = $1/\lambda$) is calculated at max output power and an operating ambient temperature (T_A) of +40°C. Flex uses Telcordia SR-332 Issue 2 Method 1 to calculate the mean steady-state failure rate and standard deviation (σ).

Telcordia SR-332 Issue 2 also provides techniques to estimate the upper confidence levels of failure rates based on the mean and standard deviation.

Mean steady-state failure rate, λ Std. deviation, σ

299 nFailures/h 42.3 nFailures/h

MTBF (mean value) for the PKM4000D series = 3.3 Mh.

MTBF at 90% confidence level = 2.8 Mh

Compatibility with RoHS requirements

The products are compatible with the relevant clauses and requirements of the RoHS directive 2002/95/EC and have a maximum concentration value of 0.1% by weight in homogeneous materials for lead, mercury, hexavalent chromium, PBB and PBDE and of 0.01% by weight in

homogeneous materials for cadmium.

Exemptions in the RoHS directive utilized in Flex products include:

- Lead in high melting temperature type solder (used to solder the die in semiconductor packages)
- Lead in glass of electronics components and in electronic ceramic parts (e.g. fill material in chip resistors)
- Lead as an alloying element in copper alloy containing up to 4% lead by weight (used in connection pins made of Brass)

Quality Statement

The products are designed and manufactured in an industrial environment where quality systems and methods like ISO 9000, 6 σ (sigma), and SPC are intensively in use to boost the continuous improvements strategy. Infant mortality or early failures in the products are screened out and they are subjected to an ATE-based final test. Conservative design rules, design reviews and product qualifications, plus the high competence of an engaged work force, contribute to the high quality of our products.

Warranty

Warranty period and conditions are defined in Flex General Terms and Conditions of Sale.

Limitation of Liability

Flex does not make any other warranties, expressed or implied including any warranty of merchantability or fitness for a particular purpose (including, but not limited to, use in life support applications, where malfunctions of product can cause injury to a person's health or life).

© Flex 2017

The information and specifications in this technical specification is believed to be correct at the time of publication. However, no liability is accepted for inaccuracies, printing errors or for any consequences thereof. Flex reserves the right to change the contents of this technical specification at any time without prior notice.

PKM 5000D PINB series Direct Converters
Input 18-75 V, Output up to 11 A / 132 W

EN/LZT 146 426 R3A Oct. 2017

© Flex

Safety Specification

General information

Flex Power DC/DC converters and DC/DC regulators are designed in accordance with the safety standards IEC 60950-1, EN 60950-1 and UL 60950-1 *Safety of Information Technology Equipment*.

IEC/EN/UL 60950-1 contains requirements to prevent injury or damage due to the following hazards:

- Electrical shock
- Energy hazards
- Fire
- Mechanical and heat hazards
- Radiation hazards
- Chemical hazards

On-board DC/DC converters and DC/DC regulators are defined as component power supplies. As components they cannot fully comply with the provisions of any safety requirements without “conditions of acceptability”. Clearance between conductors and between conductive parts of the component power supply and conductors on the board in the final product must meet the applicable safety requirements. Certain conditions of acceptability apply for component power supplies with limited stand-off (see Mechanical Information and Safety Certificate for further information). It is the responsibility of the installer to ensure that the final product housing these components complies with the requirements of all applicable safety standards and regulations for the final product.

Component power supplies for general use should comply with the requirements in IEC/EN/UL 60950-1 *Safety of Information Technology Equipment*. Product related standards, e.g. IEEE 802.3af *Power over Ethernet*, and ETS-300132-2 *Power interface at the input to telecom equipment, operated by direct current (dc)* are based on IEC/EN/UL 60950-1 with regards to safety.

Flex Power DC/DC converters, Power interface modules and DC/DC regulators are UL 60950-1 recognized and certified in accordance with EN 60950-1. The flammability rating for all construction parts of the products meet requirements for V-0 class material according to IEC 60695-11-10, *Fire hazard testing, test flames – 50 W* horizontal and vertical flame test methods.

Isolated DC/DC converters & Power interface modules

The product may provide basic or functional insulation between input and output according to IEC/EN/UL 60950-1 (see Safety Certificate), different conditions shall be met if the output of a basic or a functional insulated product shall be considered as safety extra low voltage (SELV).

output is considered as safety extra low voltage (SELV) if one of the following conditions is met:

- The input source provides supplementary or double or reinforced insulation from the AC mains according to IEC/EN/UL 60950-1.
- The input source provides functional or basic insulation from the AC mains and the product's output is reliably connected to protective earth according to IEC/EN/UL 60950-1.

For functional insulated products (see Safety Certificate) the output is considered as safety extra low voltage (SELV) if one of the following conditions is met:

- The input source provides double or reinforced insulation from the AC mains according to IEC/EN/UL 60950-1.
- The input source provides basic or supplementary insulation from the AC mains and the product's output is reliably connected to protective earth according to IEC/EN/UL 60950-1.
- The input source is reliably connected to protective earth and provides basic or supplementary insulation according to IEC/EN/UL 60950-1 and the maximum input source voltage is 60 Vdc.

Galvanic isolation between input and output is verified in an electric strength test and the isolation voltage (V_{iso}) meets the voltage strength requirement for basic insulation according to IEC/EN/UL 60950-1.

It is recommended to use a slow blow fuse at the input of each DC/DC converter. If an input filter is used in the circuit the fuse should be placed in front of the input filter. In the rare event of a component problem that imposes a short circuit on the input source, this fuse will provide the following functions:

- Isolate the fault from the input power source so as not to affect the operation of other parts of the system
- Protect the distribution wiring from excessive current and power loss thus preventing hazardous overheating

For basic insulated products (see Safety Certificate) the

PKM 5000D PINB series Direct Converters
 Input 18-75 V, Output up to 11 A / 132 W

EN/LZT 146 426 R3A Oct. 2017

© Flex

Absolute Maximum Ratings

Characteristics		min	typ	max	Unit
T_{ref}	Operating Temperature (see Thermal Consideration section)	-40		+125	°C
T_s	Storage temperature	-55		+125	°C
V_I	Input voltage	-0.5		+80	V
V_{iso}	Isolation voltage (input to output test voltage)			2250	Vdc
V_{tr}	Input voltage transient (t_p 100 ms)			100	V
V_{RC}	Remote Control pin voltage (see Operating Information section)	Positive logic option		15	V
		Negative logic option	-0.5	15	V
V_{adj}	Adjust pin voltage (see Operating Information section)	-0.5		$2xV_{oi}$	V

Stress in excess of Absolute Maximum Ratings may cause permanent damage. Absolute Maximum Ratings, sometimes referred to as no destruction limits, are normally tested with one parameter at a time exceeding the limits of Output data or Electrical Characteristics. If exposed to stress above these limits, function and performance may degrade in an unspecified manner.

Fundamental Circuit Diagram

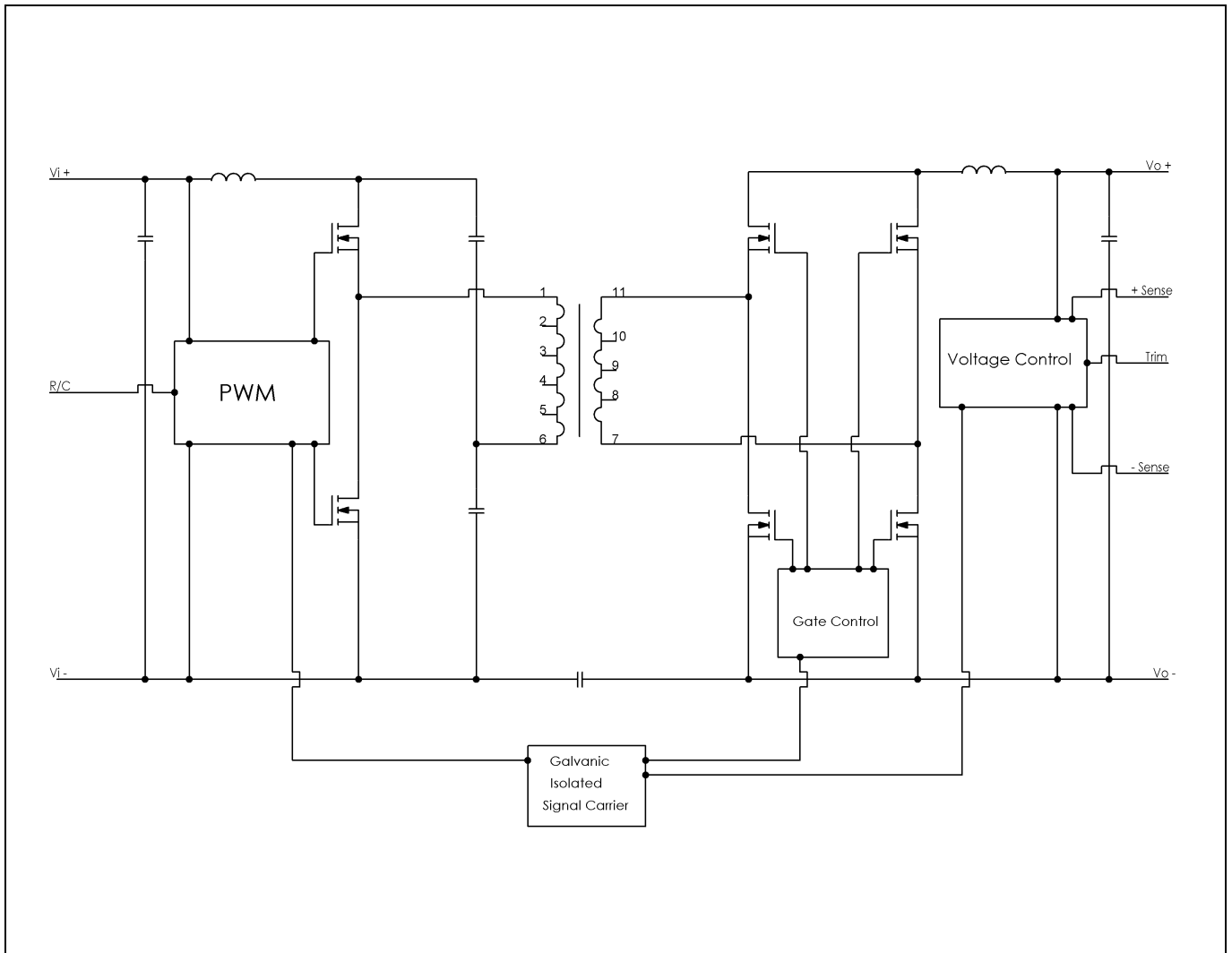

PKM 5000D PINB series Direct Converters
 Input 18-75 V, Output up to 11 A / 132 W

EN/LZT 146 426 R3A Oct. 2017

© Flex

12V/11A Electrical Specification
PKM5113D PINB
 $T_{ref} = -40$ to $+90^{\circ}\text{C}$, $V_I = 18$ to 75 V, sense pins connected to output pins unless otherwise specified under Conditions.

 Typical values given at: $T_{ref} = +25^{\circ}\text{C}$, $V_I = 53$ and 27 V, I_O max, unless otherwise specified under Conditions.

 Additional $C_{in} = 100$ μF , $C_{out} = 220$ μF . See Operating Information section for selection of capacitor types.

Characteristics		Conditions	min	typ	max	Unit
V_I	Input voltage range		18		75	V
V_{loff}	Turn-off input voltage	Decreasing input voltage	12.3	13	13.5	V
V_{lon}	Turn-on input voltage	Increasing input voltage	13.5	14.5	17.1	V
C_I	Internal input capacitance			6.9		μF
P_O	Output power	Output voltage initial setting	0		132	W
η	Efficiency	50 % of max I_O , $V_I = 27$ V		93.2		%
		max I_O , $V_I = 27$ V		91.6		
		50 % of max I_O , $V_I = 53$ V		90.2		
		max I_O , $V_I = 53$ V		90.7		
P_d	Power Dissipation	max I_O		13.6	20.6	W
P_{ii}	Input idling power	$I_O = 0$ A, $V_I = 53$ V		4.45		W
P_{RC}	Input standby power	$V_I = 53$ V (turned off with RC)		0.78		W
f_s	Switching frequency	0-100 % of max I_O	180	200	220	kHz

V_{Oi}	Output voltage initial setting and accuracy	$T_{ref} = +25^{\circ}\text{C}$, $V_I = 27\text{V}$, 53V , $I_O = 10$ A	11.64	12.00	12.36	V
V_O	Output adjust range	See operating information	10.8		13.2	V
	Output voltage tolerance band	0-100 % of max I_O $V_I = 20-75\text{V}$	11.64	12.00	12.36	V
	Idling voltage	$I_O = 0$ A	11.64	12.00	12.36	V
	Line regulation	max I_O , $V_I = 18-75\text{V}$		30	120	mV
	Load regulation	$V_I = 27\text{V}$, 53V 0-100 % of max I_O		20	35	mV
V_{tr}	Load transient voltage deviation	$V_I = 27\text{V}$, 53V , Load step 25-75-25 % of max I_O , $di/dt = 1$ A/ μs , Note 1		± 350	± 450	mV
t_{tr}	Load transient recovery time			100		μs
t_r	Ramp-up time (from 10-90 % of V_{Oi})	0-100% of max I_O		21		ms
t_s	Start-up time (from V_I connection to 90 % of V_{Oi})			25		ms
t_f	V_I shut-down fall time (from V_I off to 10 % of V_O)	max I_O , $V_{in} = 27\text{V}$		0.727		ms
		$I_O = 0.5$ A,		15		ms
t_{RC}	RC start-up time	max I_O		50		ms
	RC shut-down fall time (from RC off to 10 % of V_O)	max I_O ,		0.915		ms
		$I_O = 0.5$ A,		10		ms
I_O	Output current		0		11	A
I_{lim}	Current limit threshold	$T_{ref} < \text{max } T_{ref}$	12	14	20	A
I_{sc}	Short circuit current	$T_{ref} = 25^{\circ}\text{C}$ Note 2		3		A
C_{out}	Recommended Capacitive Load	$T_{P1} = 25^{\circ}\text{C}$		1100	5500	μF
V_{Oac}	Output ripple & noise	See ripple & noise section, max I_O , $V_{in} = 27\text{V}$		100		mVp-p
OVP	Over voltage protection	$T_{ref} = +25^{\circ}\text{C}$, $V_I = 53$ V, 100 % of max I_O		16		V

 Note 1: $C_o = 1100\mu\text{F}$ aluminum solid capacitors are connected to the module.

Note 2: Hic-cup mode, the value is in RMS, short circuit load is 5mohm

PKM 5000D PINB series Direct Converters
 Input 18-75 V, Output up to 11 A / 132 W

EN/LZT 146 426 R3A Oct. 2017

© Flex

12V/11A Typical Characteristics

PKM5113D PINB

Efficiency

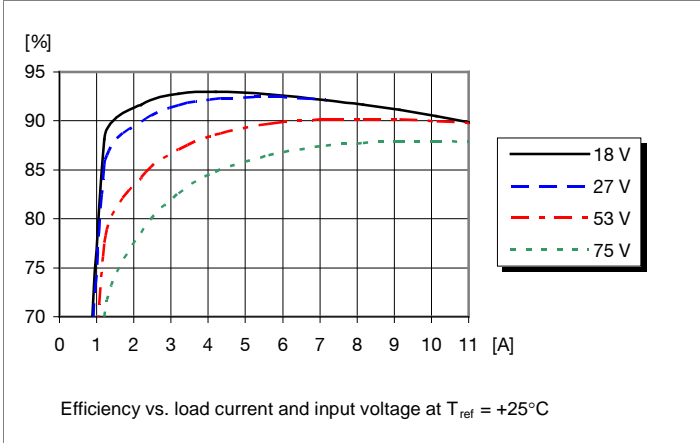

Power Dissipation

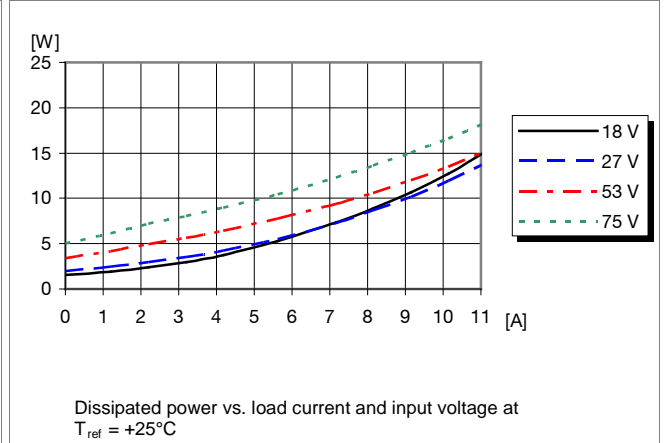

Output Characteristics

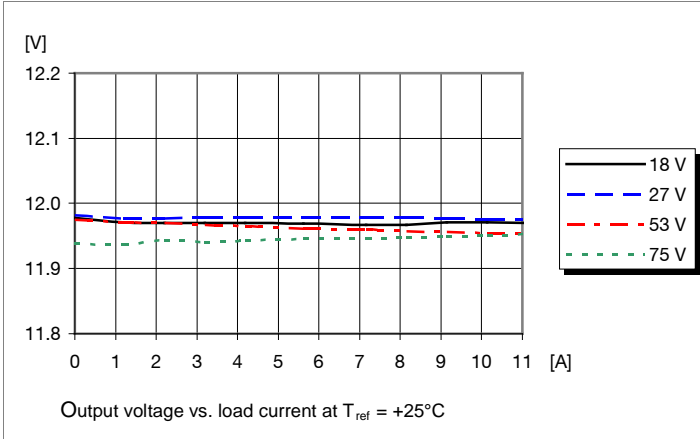

Current Limit Characteristics

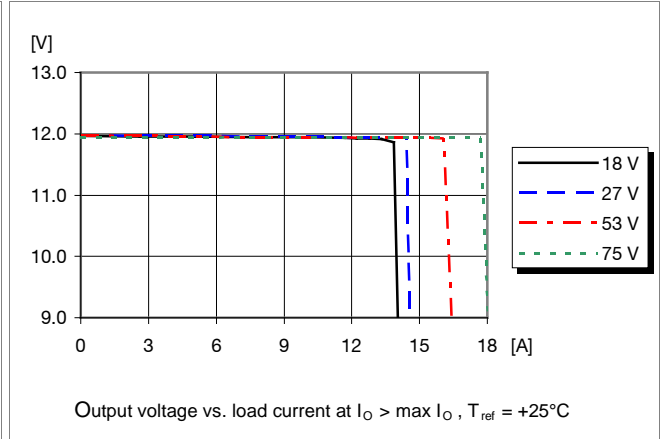

PKM 5000D PINB series Direct Converters
 Input 18-75 V, Output up to 11 A / 132 W

EN/LZT 146 426 R3A Oct. 2017

© Flex

12V/11A Typical Characteristics

PKM5113D PINB

Start-up

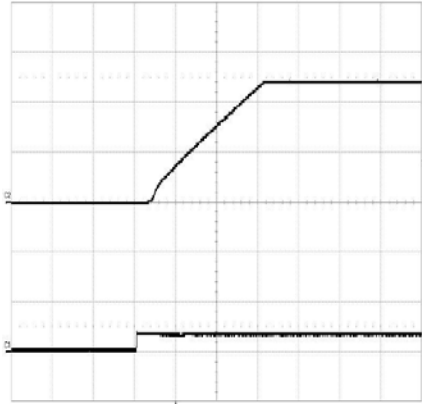

Start-up enabled by connecting V_1 at:
 $T_{ref} = +25^\circ\text{C}$, $V_1 = 27\text{ V}$, $C_{in}=100\mu\text{F}$
 $I_O = 11\text{ A}$ resistive load.

Top trace: output voltage 5 V/div.
 Bottom trace: 50V/div
 Time scale: 10 ms/div.

Shut-down

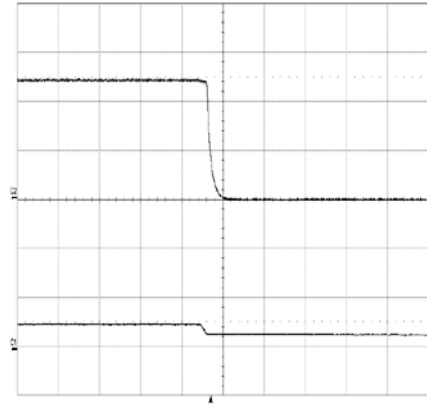

Shut-down enabled by disconnecting V_1 at:
 $T_{ref} = +25^\circ\text{C}$, $V_1 = 27\text{ V}$, $C_{in}=220\mu\text{F}$
 $I_O = 11\text{ A}$ resistive load.

Top trace: output voltage 5 V/div.
 Bottom trace: input voltage 50 V/div.
 Time scale: 2 ms/div.

Output Ripple & Noise

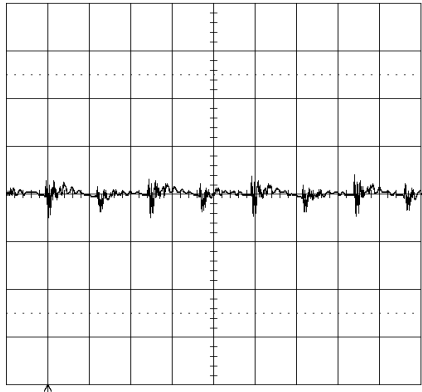

Output voltage ripple at:
 $T_{ref} = +25^\circ\text{C}$, $V_1 = 27\text{ V}$, $C_{in}=220\mu\text{F}$
 $I_O = 11\text{ A}$ resistive load.

Trace: output voltage 50 mV/div.
 Time scale: 2 μs/div.

Output Load Transient Response

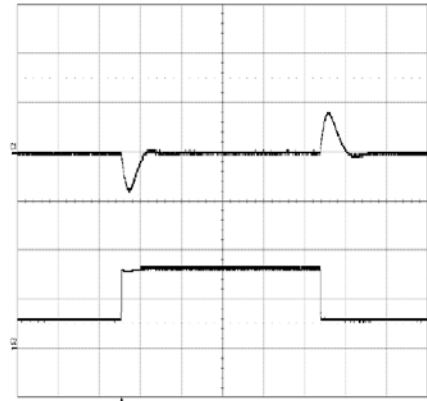

Output voltage response to load current step-
 change 2.5-7.5-2.5 A at: 1A/us, 1100μF
 capacitive load, $T_{ref} = +25^\circ\text{C}$, $V_1 = 27\text{ V}$.

Top trace: output voltage 0.5V/div.
 Bottom trace: load current
 Time scale: 1 ms/div.

Output Voltage Adjust (see operating information)

Passive adjust

Output Voltage Adjust Upwards, Increase:

$$R_{adj} = \left(\frac{5.11 \times 12(100 + \Delta\%) - 511}{1.225 \times \Delta\%} - 10.22 \right) \text{ k}\Omega$$

Example: Increase 4% $\Rightarrow V_{out} = 12.48\text{ Vdc}$

$$\left(\frac{5.11 \times 12(100 + 4)}{1.225 \times 4} - \frac{511}{4} - 10.22 \right) \text{ k}\Omega = 1163\text{ k}\Omega$$

Output Voltage Adjust Downwards, Decrease:

$$R_{adj} = 5.11 \left(\frac{100}{\Delta\%} - 2 \right) \text{ k}\Omega$$

Example: Decrease 2% $\Rightarrow V_{out} = 11.76\text{ Vdc}$

$$5.11(100/2-2) = 245\text{ k}\Omega$$

PKM 5000D PINB series Direct Converters
 Input 18-75 V, Output up to 11 A / 132 W

EN/LZT 146 426 R3A Oct. 2017

© Flex

12V, 11A /132W Typical Characteristics

PKM5113D PINB

Output Current Derating – Open frame

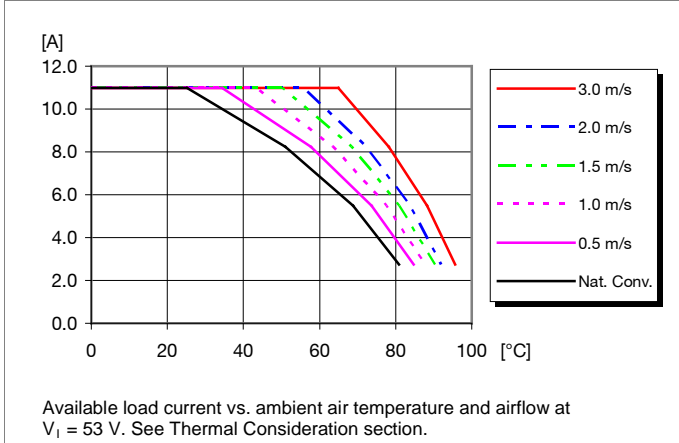

Output Current Derating – Base plate

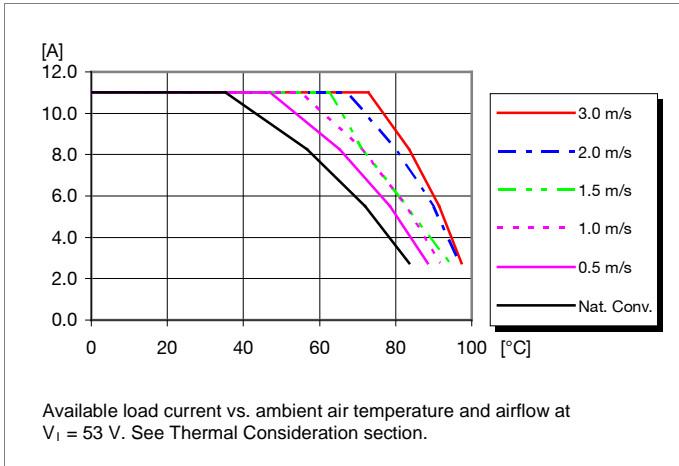

Thermal Resistance – Base plate

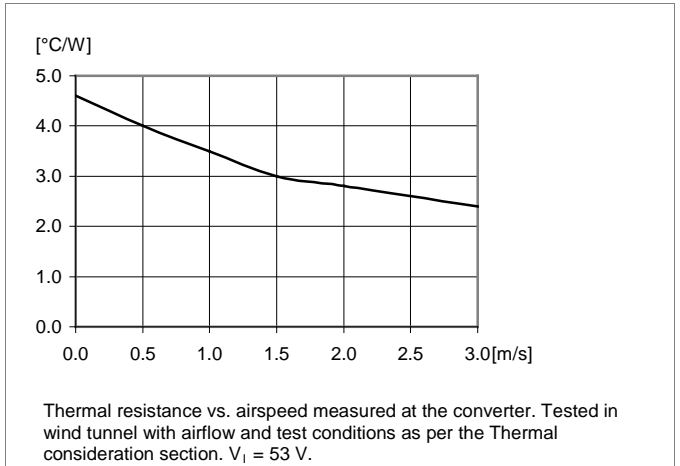

Output Current Derating – Cold wall sealed box

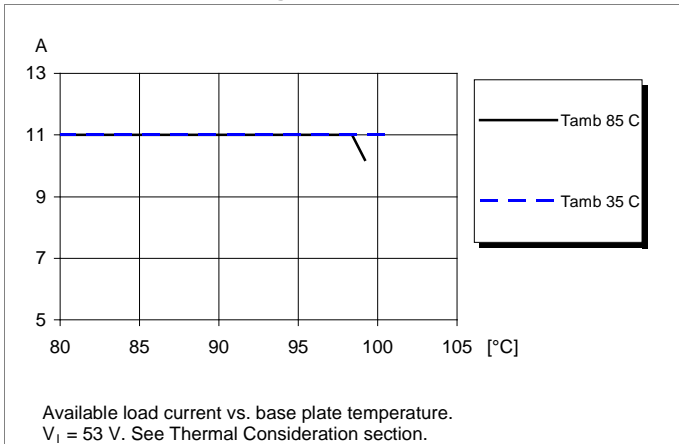

PKM 5000D PINB series Direct Converters
 Input 18-75 V, Output up to 11 A / 132 W

EN/LZT 146 426 R3A Oct. 2017

© Flex

12V, 11A /132W Typical Characteristics

PKM5113D PINB

Output Current Derating – Open frame

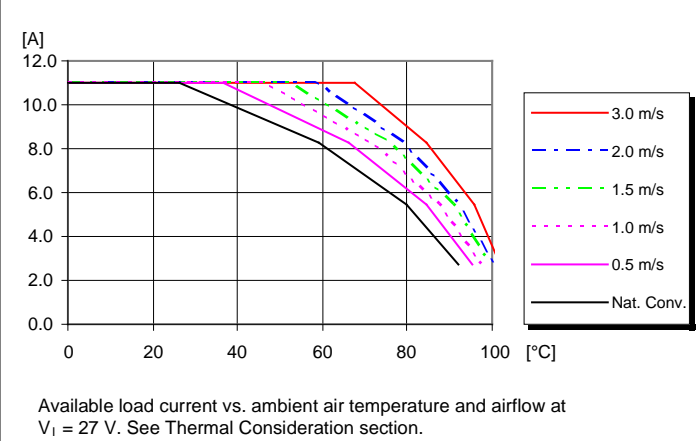

Output Current Derating – Base plate

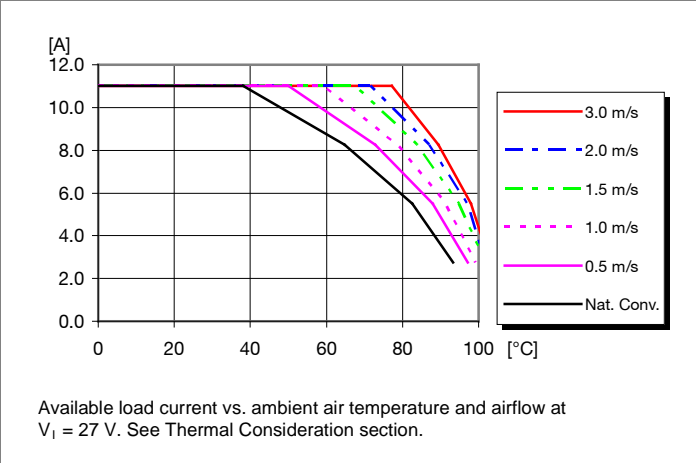

Thermal Resistance – Base plate

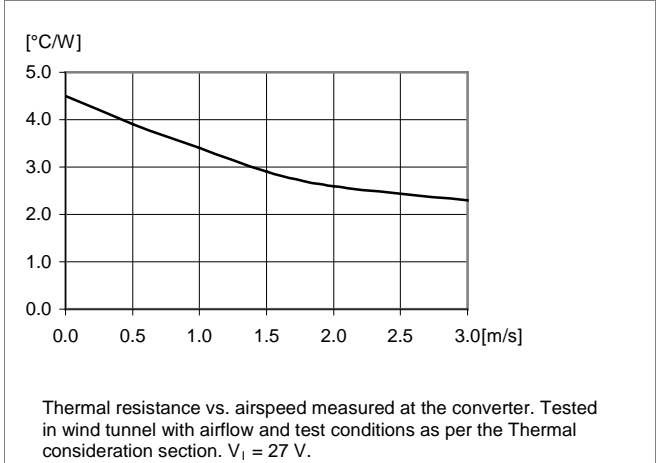

Output Current Derating – Cold wall sealed box

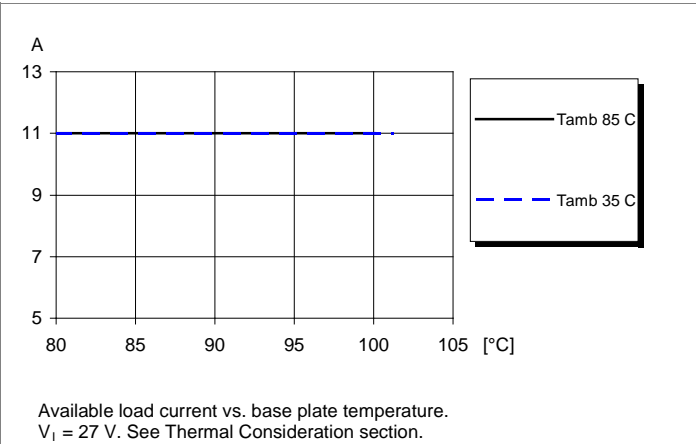

PKM 5000D PINB series Direct Converters
 Input 18-75 V, Output up to 11 A / 132 W

EN/LZT 146 426 R3A Oct. 2017

© Flex

12V, 11A /132W Typical Characteristics

PKM5113D PINB

Output Current Derating – Base plate + Heat sink

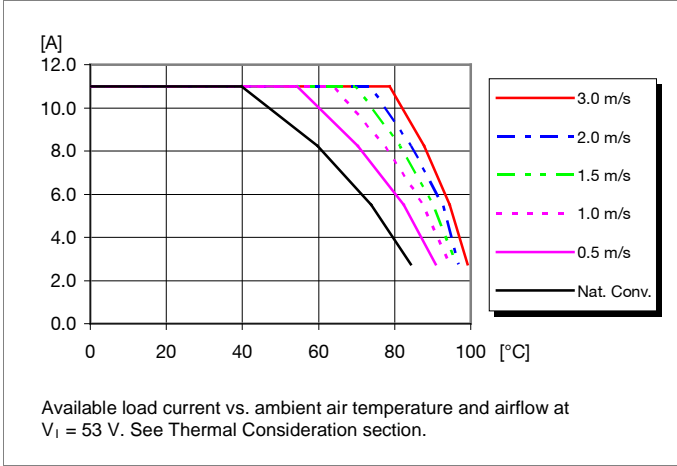

Thermal Resistance – Base plate + Heat sink

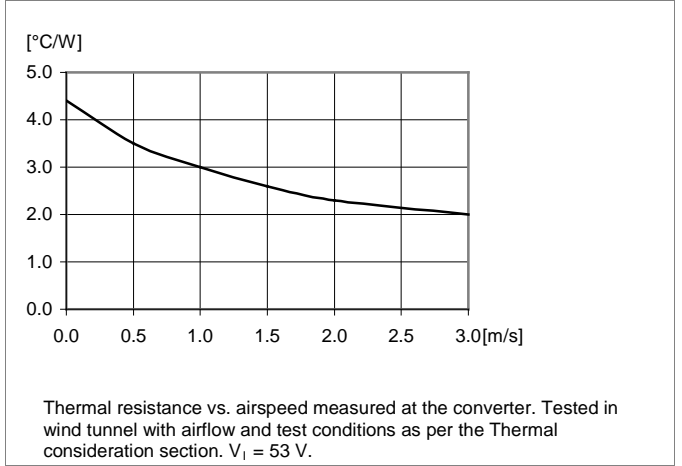

Output Current Derating – Base plate + Heat sink

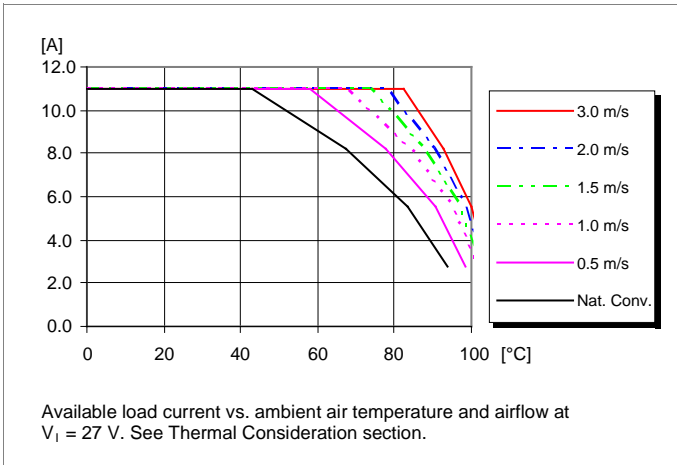

Thermal Resistance – Base plate

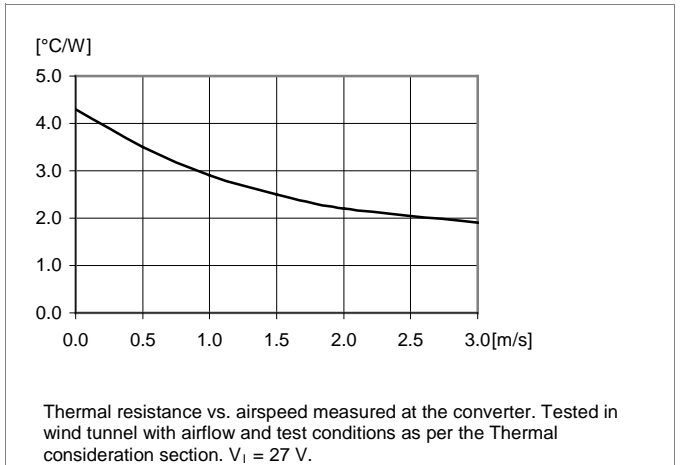

PKM 5000D PINB series Direct Converters
 Input 18-75 V, Output up to 11 A / 132 W

EN/LZT 146 426 R3A Oct. 2017

© Flex

EMC Specification

Conducted EMI measured according to EN55022, CISPR 22 and FCC part 15J (see test set-up).
 The fundamental switching frequency is 200 kHz for PKM 5113D PINB @ $V_I = 48\text{ V}$, $C_{in} = 220\mu\text{F}$, max I_O .

Conducted EMI Input terminal value (typ)

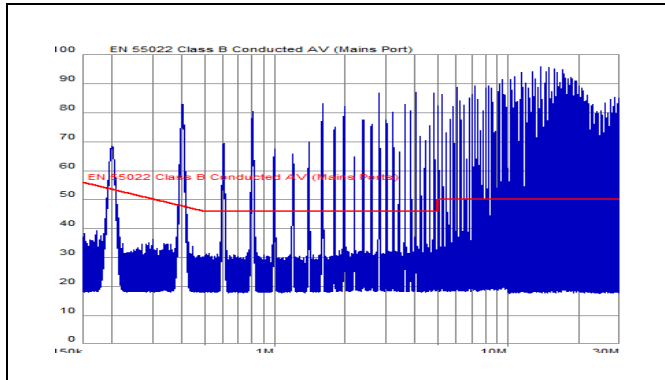

EMI without filter

External filter (class B)

Required external input filter in order to meet class B in EN 55022, CISPR 22 and FCC part 15J.

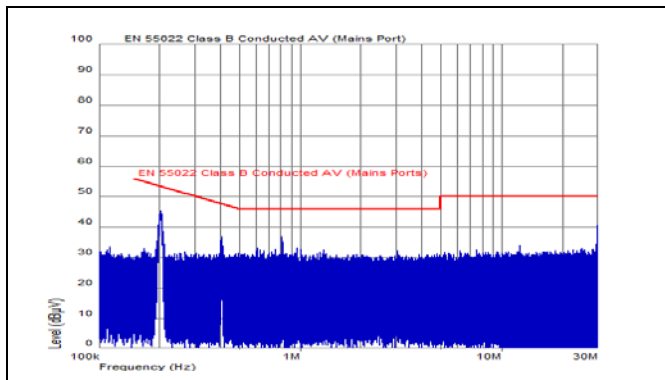
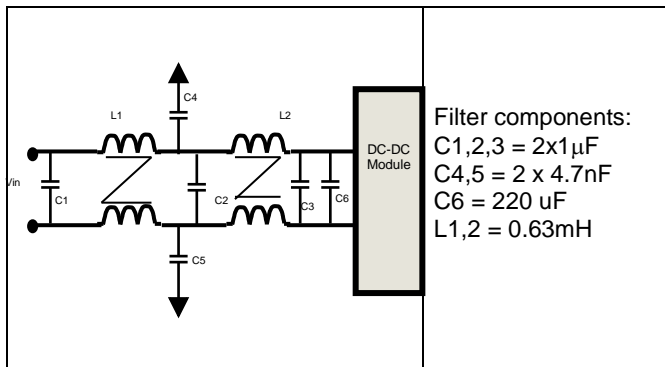

EMI with filter

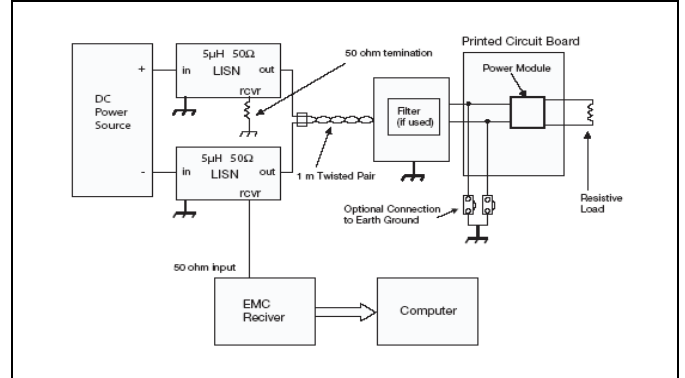

Test set-up

Layout recommendation

The radiated EMI performance of the DC/DC converter will depend on the PCB layout and ground layer design. It is also important to consider the stand-off of the DC/DC converter. If a ground layer is used, it should be connected to the output of the DC/DC converter and the equipment ground or chassis.

A ground layer will increase the stray capacitance in the PCB and improve the high frequency EMC performance.

Output ripple and noise

Output ripple and noise measured according to figure below. See Design Note 022 for detailed information.

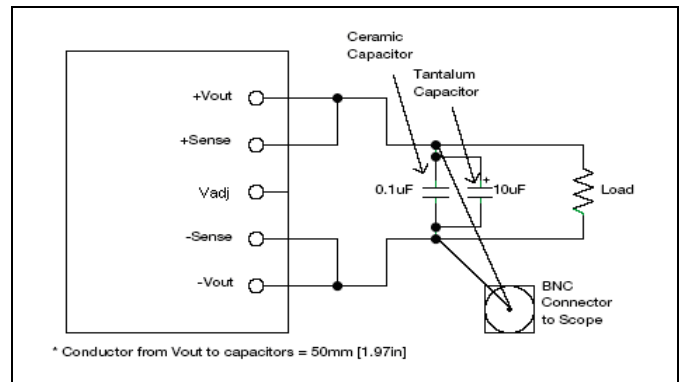

Output ripple and noise test setup

PKM 5000D PINB series Direct Converters
 Input 18-75 V, Output up to 11 A / 132 W

EN/LZT 146 426 R3A Oct. 2017

© Flex

Operating information

Input Voltage

The input voltage range 18 to 75Vdc meets the requirements of the European Telecom Standard ETS 300 132-2 for normal input voltage range in -48 and -60 Vdc systems, -40.5 to -57.0 V and -50.0 to -72 V respectively. At input voltages exceeding 75 V, the power loss will be higher than at normal input voltage and T_{ref} must be limited to absolute max +125°C. The absolute maximum continuous input voltage is 80Vdc.

Turn-off Input Voltage

The PKM 5000D Series DC/DC converters monitor the input voltage and will turn on and turn off at predetermined levels. The minimum hysteresis between turn on and turn off input voltage is 1 V.

Remote Control (RC)

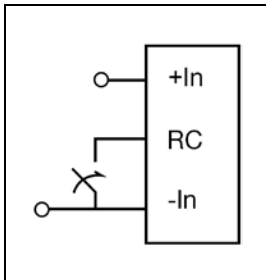

The products are fitted with a remote control function referenced to the primary negative input connection (- In), with negative and positive logic options available. The RC function allows the converter to be turned on/off by an external device like a semiconductor or mechanical switch. The RC pin has an internal pull up resistor to + In.

The maximum required sink current is 1 mA. When the RC pin is left open, the voltage generated on the RC pin is 3.5 – 6.0V. The second option is “positive logic” remote control, which can be ordered by adding the suffix “P” to the end of the part number. The converter will turn on when the input voltage is applied with the RC pin open. Turn off is achieved by connecting the RC pin to the - In. To ensure safe turn off the voltage difference between RC pin and the - In pin shall be less than 1V. The converter will restart automatically when this connection is opened.

See Design Note 021 for detailed information.

Input and Output Impedance

The impedance of both the power source and the load will interact with the impedance of the DC/DC converter. It is most important to have a low characteristic impedance, both at the input and output, as the converters have a low energy storage capability. The performance in some applications can be enhanced by addition of external capacitance as described under maximum capacitive load. If the distribution of the input voltage source to the converter contains significant inductance, the addition of a 100µF capacitor across the input of the converter will help insure stability. This capacitor is not required when powering the DC/DC converter from a low impedance source with short, low inductance, input power leads.

External Decoupling Capacitors

When powering loads with significant dynamic current requirements, the voltage regulation at the point of load can be improved by addition of decoupling capacitors at the load. The most effective technique is to locate low ESR ceramic and electrolytic capacitors as close to the load as possible, using several parallel capacitors to lower the effective ESR. The ceramic capacitors will handle high-frequency dynamic load changes while the electrolytic capacitors are used to handle low frequency dynamic load changes. Ceramic capacitors will also reduce any high frequency noise at the load. It is equally important to use low resistance and low inductance PCB layouts and cabling.

External decoupling capacitors will become part of the control loop of the DC/DC converter and may affect the stability margins. As a “rule of thumb”, 100 µF/A of output current can be added without any additional analysis. The ESR of the capacitors is a very important parameter. Power Modules guarantee stable operation with a verified ESR value of >10 mΩ across the output connections.

For further information please contact your local Flex representative.

Output Voltage Adjust (V_{adj})

All PKM 5000D Series DC/DC converters have an Output Voltage adjust pin (V_{adj}). This pin can be used to adjust the output voltage above or below Output voltage initial setting. When increasing the output voltage, the voltage at the output pins (including any remote sense offset) must be kept below the maximum output adjust range. Also note that at increased output voltages the maximum power rating of the converter remains the same, and the output current capability will decrease correspondingly.

To decrease the output voltage the resistor should be connected between V_{adj} pin and -Sense pin. To increase the voltage the resistor should be connected between V_{adj} pin and +Sense pin. The resistor value of the Output voltage adjust function is according to information given under the output section.

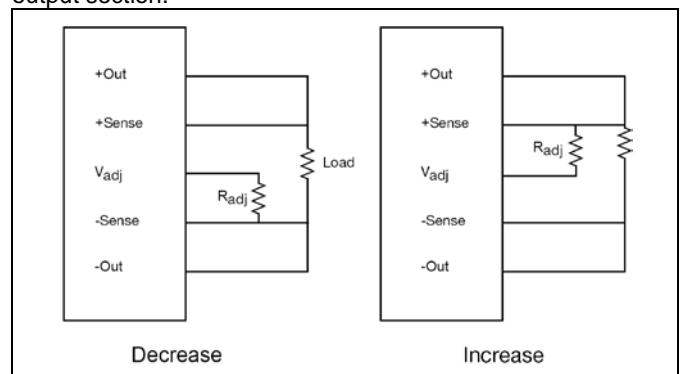

PKM 5000D PINB series Direct Converters
Input 18-75 V, Output up to 11 A / 132 W

EN/LZT 146 426 R3A Oct. 2017

© Flex

Operating information continued

Parallel Operation

The PKM 5000D Series DC/DC converters can be paralleled for redundancy if external o-ring diodes are used in series with the outputs. It is not recommended to parallel the PKM 5000D Series DC/DC converters for increased power without using external current sharing circuits.

See Design Note 006 for detailed information.

Remote Sense

All PKM 5000D Series DC/DC converters have remote sense that can be used to compensate for moderate amounts of resistance in the distribution system and allow for voltage regulation at the load or other selected point. The remote sense lines will carry very little current and do not need a large cross sectional area. However, the sense lines on the Pcb should be located close to a ground trace or ground plane. In a discrete wiring situation, the use of twisted pair wires or other technique to reduce noise susceptibility is highly recommended. The remote sense circuitry will compensate for up to 10% voltage drop between the sense voltage and the voltage at the output pins. The output voltage and the remote sense voltage offset must be less than the minimum over voltage trip point. If the remote sense is not needed the –Sense should be connected to –Out and +Sense should be connected to +Out.

Over Temperature Protection (OTP)

The PKM 5000D Series DC/DC converters are protected from thermal overload by an internal over temperature shutdown circuit. When the Pcb temperature (TC reference point) exceeds the temperature trig point (~125 °C) the OTP circuit will cut down output power. The converter will stop until safe operating temperature is restored. Hysteresis between OTP trig point and restart is approx 10°C. Time between OTP and restart is dependant on cooling of DC/DC converter.

Over Voltage Protection (OVP)

The PKM 5000D Series DC/DC converters have output overvoltage protection. In the event of an output overvoltage condition, the converter will shut down immediately. The converter make continous attempts to start up (non-latching mode) and resume normal operation automatically.

Over Current Protection (OCP)

The PKM 5000D Series DC/DC converters include current limiting circuitry that allows them to withstand continuous overloads or short circuit conditions on the output. the output voltage will decrease when the output current in excess of its current limit point, when the load continue to increase to some higher level, the module will enter into hiccup mode.

During hiccup, the module will try to restart and shutdown again for the overload. When the overload is removed, the products will continue to work normally.

Thermal Consideration

General

The PKM 5000D series DC/DC converters are designed to operate in a variety of thermal environments, however sufficient cooling should be provided to help ensure reliable operation. Heat is removed by conduction, convection and radiation to the surrounding environment. Increased airflow enhances the heat transfer via convection. The available load current vs. ambient air temperature and airflow at $V_{in} = 53$ V for each model is according to the information given under the output section. The test is done in a wind tunnel with a cross section of 305 x 305 mm, the DC/DC converter vertically mounted on a 16 layer Pcb with a size of 254 x 254 mm, each layer with 35 μm (1 oz) copper. Proper cooling can be verified by measuring the temperature of selected devices. Peak temperature can occur at positions P1 - P4. The temperature at these positions should not exceed the recommended max values.

Note that the max value is the absolute maximum rating (non destruction) and that the electrical Output data is guaranteed up to $T_{ref} + 90^{\circ}\text{C}$.

See Design Note 019 for further information.

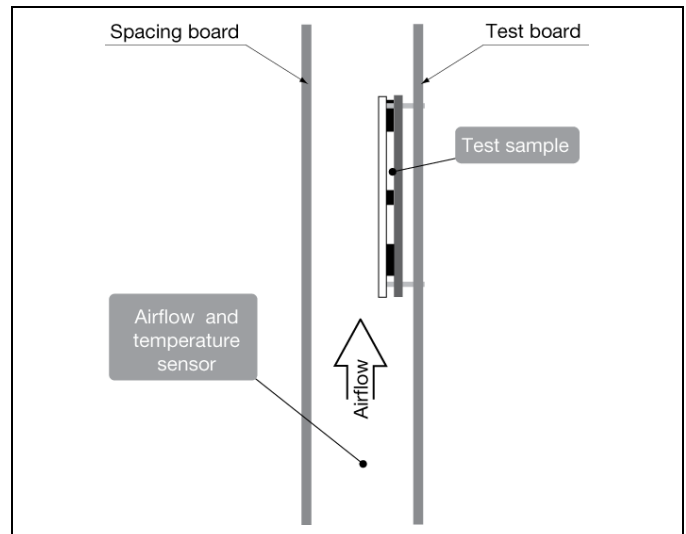

For products with base plate used in a sealed box/cold wall application, cooling is achieved mainly by conduction through the cold wall. The Output Current Derating graphs are found in the Output section for each model. The product is tested in a sealed box test set up with ambient temperatures 85 and 35°C. See Design Note 028 for further details.

PKM 5000D PINB series Direct Converters Input 18-75 V, Output up to 11 A / 132 W

EN/LZT 146 426 R3A Oct. 2017

© Flex

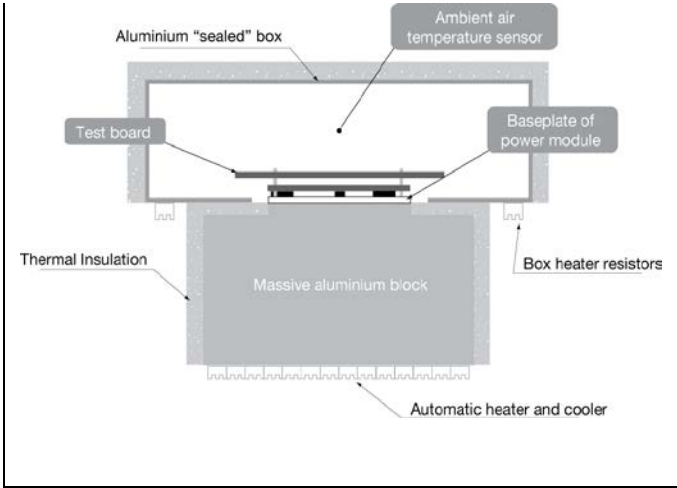

Ambient Temperature Calculation

By using the thermal resistance the maximum allowed ambient temperature can be calculated.

1. The power loss is calculated by using the formula $((1/\eta) - 1) \times \text{output power} = \text{power losses (Pd)}$.
 η = efficiency of converter. E.g 89.6 % = 0.896

2. Find the thermal resistance (Rth) in the Thermal Resistance graph found in the Output section for each model.
 Calculate the temperature increase (ΔT).

$\Delta T = R_{th} \times P_d$

3. Max allowed ambient temperature is:
 Max Tref - ΔT .

E.g PKM 5113D PINB at 2m/s:

1. $((1/0.897) - 1) \times 132 \text{ W} = 15 \text{ W}$

2. $15 \text{ W} \times 3.4^\circ\text{C/W} = 51^\circ\text{C}$

3. $110^\circ\text{C} - 51^\circ\text{C} = \text{max ambient temperature is } 59^\circ\text{C}$

The real temperature will be dependent on several factors, like Pcb size and type, direction of airflow, air turbulence etc. It is recommended to verify the temperature by testing.

Thermal Consideration continued

Definition of reference temperature (T_{ref})

The reference temperature is used to monitor the temperature limits of the product. Temperatures above maximum T_{ref} are not allowed and may cause degradation or permanent damage to the product. T_{ref} is also used to define the temperature range for normal operating conditions.

T_{ref} is defined by the design and used to guarantee safety margins, proper operation and high reliability of the module.

Position	Device	Designation	max value
P ₁	Pcb	T _{ref}	110° C
P ₂	Mosfet	T _{surface}	125° C
P ₃	Mosfet	T _{surface}	125° C
P ₄	Transformer	T _{surface}	125° C

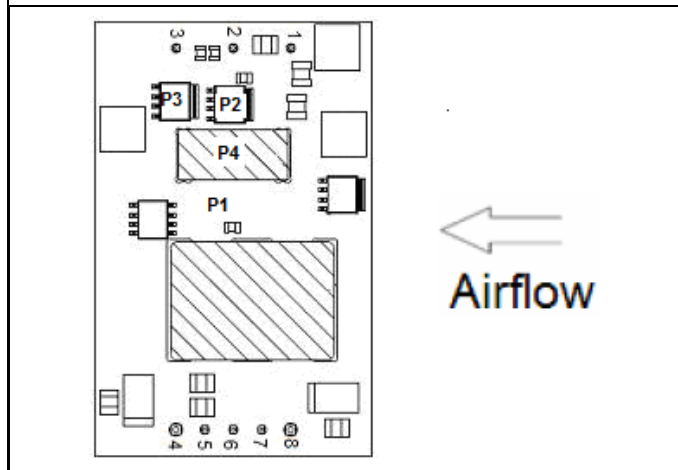

Top view, air flow: from positive to negative

PKM 5000D PINB series Direct Converters
 Input 18-75 V, Output up to 11 A / 132 W

EN/LZT 146 426 R3A Oct. 2017

© Flex

Connections

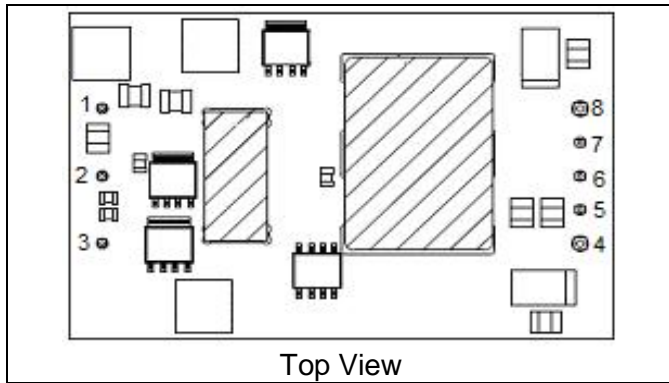

Pin	Designation	Function
1	+In	Positive input
2	RC	Remote control
3	- In	Negative input
4	- Out	Negative output
5	- Sen	Negative remote sense
6	Vadj	Output voltage adjust
7	+ Sen	Positive remote sense
8	+ Out	Positive output

PKM 5000D PINB series Direct Converters
 Input 18-75 V, Output up to 11 A / 132 W

EN/LZT 146 426 R3A Oct. 2017

© Flex

Mechanical Information for open frame option

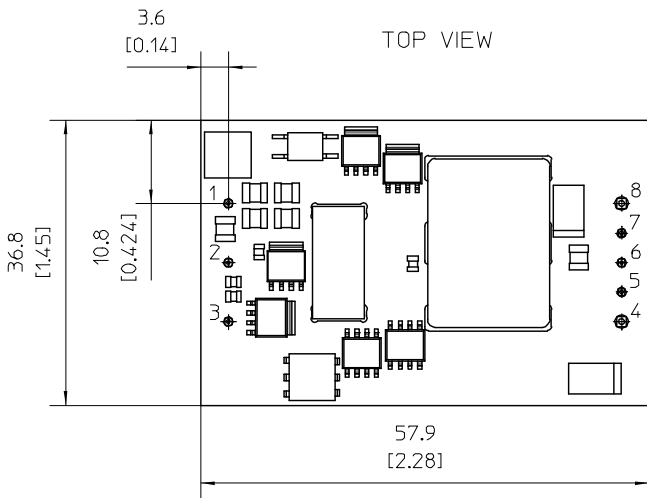
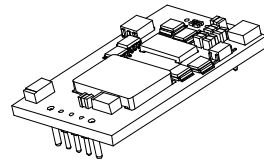
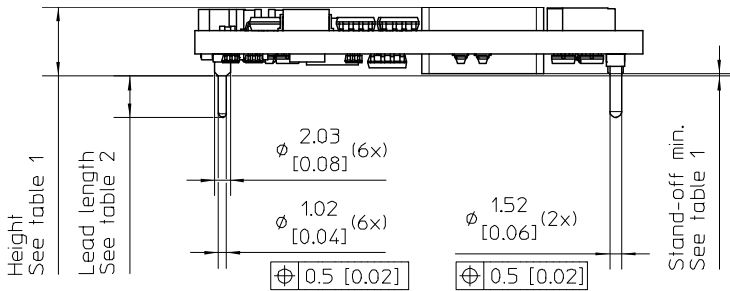

Recommended footprint - TOP VIEW

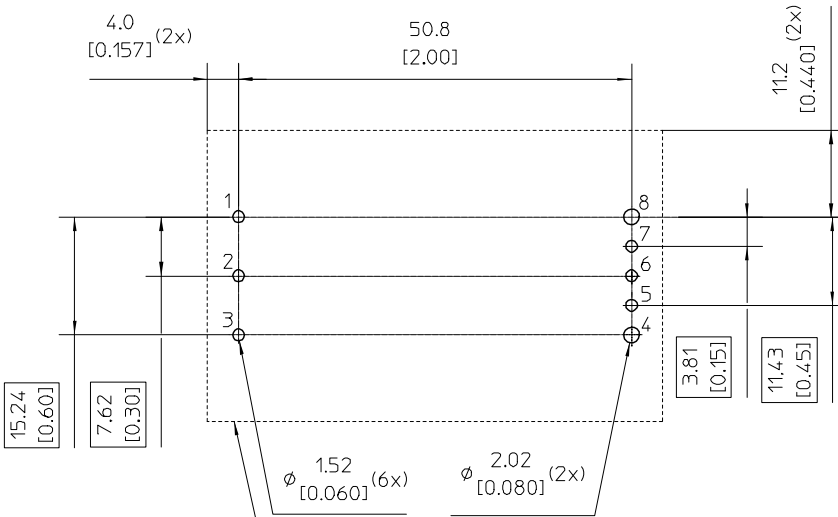

Recommended keep away area for user components.

Table 1

Height option	Height max.	Stand-off min.
Standard	9.7 [0.382]	0.07 [0.003]
M	10.53 [0.415]	0.9 [0.035]

Table 2

Pin option	Lead Length
Standard	5.33 [0.210]
LA	3.69 [0.145]
LB	4.57 [0.180]

Weight: Typical 40g

Pins:

Material, pins 1-3, 5-7: Brass
 Material, pins 4, 8: Copper alloy
 Plating: 0.1µm Gold over 2µm Nickel

All dimensions are in mm [inches]
 Tolerances unless specified
 x.x±0.5[0.02]
 x.xx±0.25[0.01]
 Not applied on the recommended footprint



PKM 5000D PINB series Direct Converters
 Input 18-75 V, Output up to 11 A / 132 W

EN/LZT 146 426 R3A Oct. 2017

© Flex

Mechanical Information for base plate option

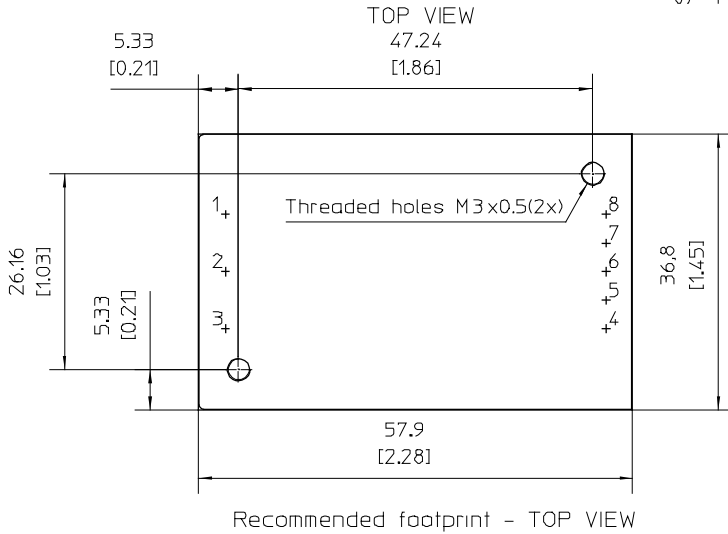
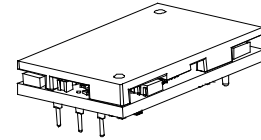
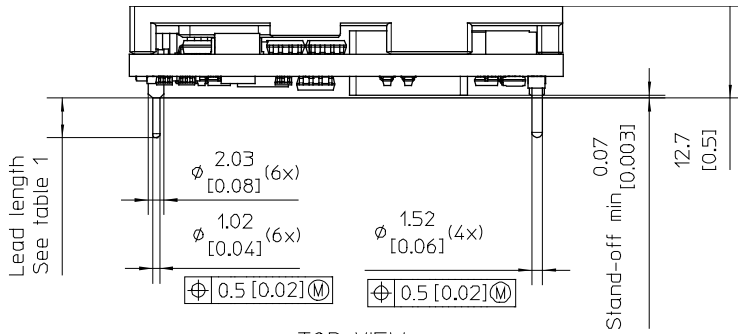

Table 1

Pin option	Lead Length
Standard	5.33 [0.210]
LA	3.69 [0.145]
LB	4.57 [0.180]

Case:

Material: Aluminium

- For screw attachment apply mounting torque of max 0.44 Nm [3.9 lbf in].
- M3 screws must not protrude more than 2.5 [0.10] in to the base plate.

Weight: Typical 68g

Pins:

Material, pins 1-3, 5-7: Brass

Material, pins 4,8: Copper alloy

Plating: 0,1 μ m Gold over 2 μ m Nickel

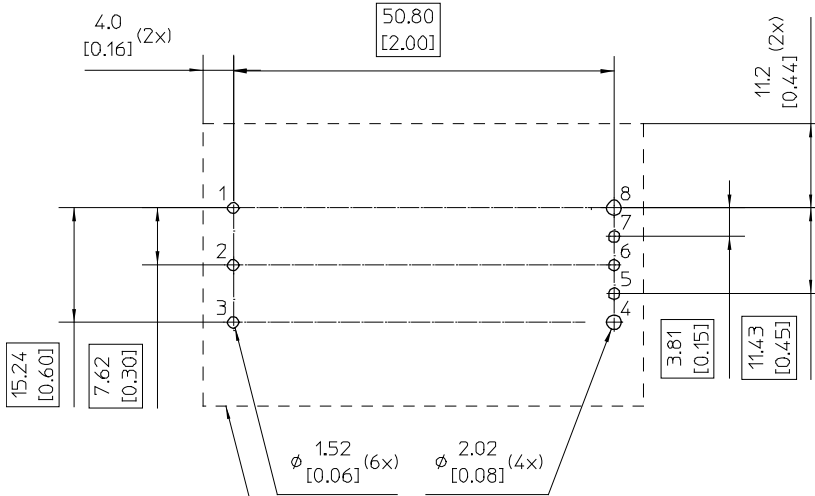

Recommended keep away area for user components.

All dimensions are in mm [inches]

Tolerances unless specified

x.x \pm 0.5 [0.02]

x.xx \pm 0.25 [0.01]

Not applied on the recommended footprint



PKM 5000D PINB series Direct Converters
 Input 18-75 V, Output up to 11 A / 132 W

EN/LZT 146 426 R3A Oct. 2017

© Flex

Soldering Information - Hole Mounting

The hole mounted product is intended for plated through hole mounting by wave or manual soldering. The pin temperature is specified to maximum to 270°C for maximum 10 seconds.

A maximum preheat rate of 4°C/s and maximum preheat temperature of 150°C is suggested. When soldering by hand, care should be taken to avoid direct contact between the hot soldering iron tip and the pins for more than a few seconds in order to prevent overheating.

A no-clean flux is recommended to avoid entrapment of cleaning fluids in cavities inside the product or between the product and the host board. The cleaning residues may affect long time reliability and isolation voltage.

Delivery Package Information

The products are delivered in antistatic trays

Tray Specifications	
Material	Antistatic PS
Surface resistance	$10^5 < \text{Ohm/square} < 10^{12}$
Bakability	The trays are not bakeable
Tray thickness	26 mm [1.02 inch]
Box capacity	20 products (1 full tray/box)
Tray weight	140 g empty, 940 g full tray

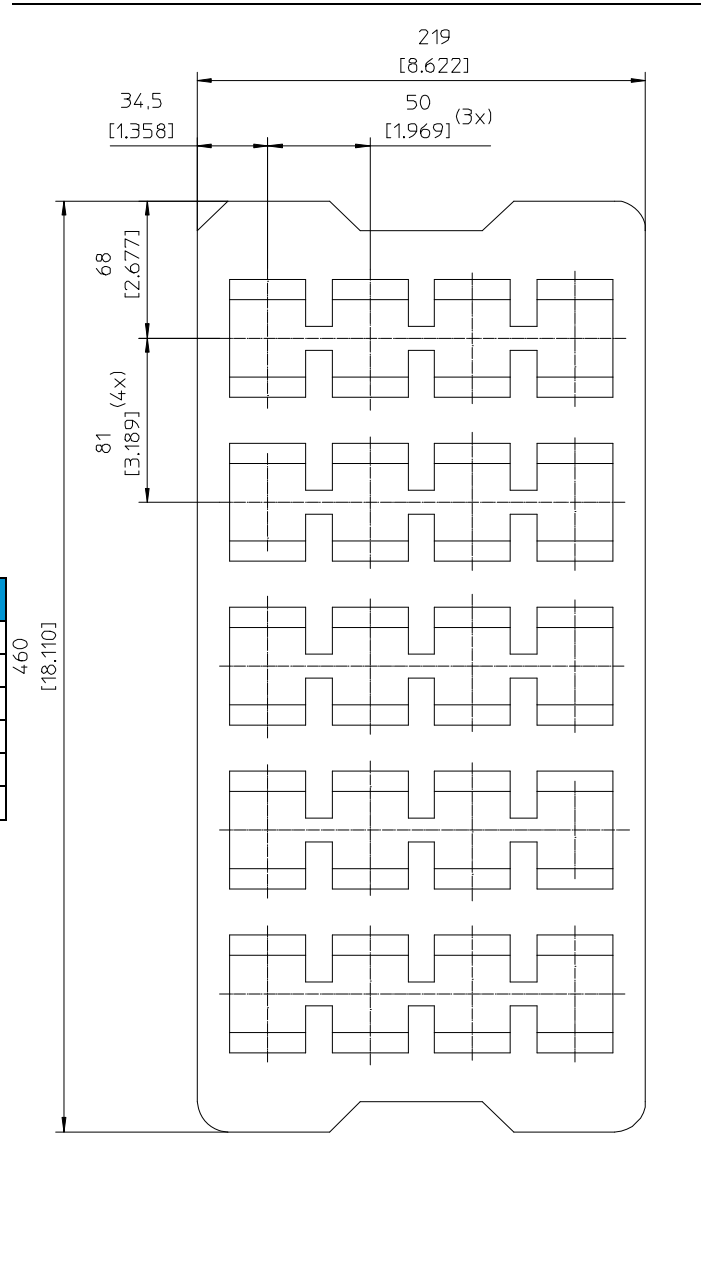

PKM 5000D PINB series Direct Converters
 Input 18-75 V, Output up to 11 A / 132 W

EN/LZT 146 426 R3A Oct. 2017

© Flex

Product Qualification Specification

Characteristics			
External visual inspection	IPC-A-610		
Change of temperature (Temperature cycling)	IEC 60068-2-14 Na	Temperature range Number of cycles Dwell/transfer time	-40 to 100°C 1000 15 min/0-1 min
Cold (in operation)	IEC 60068-2-1 Ad	Temperature T _A Duration	-45°C 72 h
Damp heat	IEC 60068-2-67 Cy	Temperature Humidity Duration	85°C 85 % RH 1000 hours
Dry heat	IEC 60068-2-2 Bd	Temperature Duration	125°C 1000 h
Electrostatic discharge susceptibility	IEC 61340-3-1, JESD 22-A114 IEC 61340-3-2, JESD 22-A115	Human body model (HBM) Machine Model (MM)	Class 2, 2000 V Class 3, 200 V
Immersion in cleaning solvents	IEC 60068-2-45 XA, method 2	Water Glycol ether Isopropyl alcohol	55°C 35°C 35°C
Mechanical shock	IEC 60068-2-27 Ea	Peak acceleration Duration	100 g 6 ms
Moisture reflow sensitivity ¹	J-STD-020C	Level 1 (SnPb-eutectic) Level 3 (Pb Free)	225°C 260°C
Operational life test	MIL-STD-202G, method 108A	Duration	1000 h
Resistance to soldering heat ²	IEC 60068-2-20 Tb, method 1A	Solder temperature Duration	270°C 10-13 s
Robustness of terminations	IEC 60068-2-21 Test Ua1 IEC 60068-2-21 Test Ue1	Through hole mount products Surface mount products	All leads All leads
Solderability	IEC 60068-2-58 test Td ¹	Preconditioning Temperature, SnPb Eutectic Temperature, Pb-free	150°C dry bake 16 h 215°C 235°C
	IEC 60068-2-20 test Ta ²	Preconditioning Temperature, SnPb Eutectic Temperature, Pb-free	Steam ageing 235°C 245°C
Vibration, broad band random	IEC 60068-2-64 Fh, method 1	Frequency Spectral density Duration	10 to 500 Hz 0.07 g ² /Hz 10 min in each direction

Notes
¹ Only for products intended for reflow soldering (surface mount products)

² Only for products intended for wave soldering (plated through hole products)