

PMT 8318VS series PoL Regulators
 Input 4.5-14 V, Output up to 6 A / 30 W

28701- BMR 708 0010 Rev. B November 2018

© Flex

Key Features

- Compact and low profile package
 12.2 x 12.2 x 7.2 mm (0.48 x 0.48 x 0.283 in)
- High efficiency, typ. 95.1% at 5 Vout full load
- Wide operating input range: 4.5V - 14V
- Adjustable Output Voltage: 0.8V - 5.5V
- Meet safety requirements according to IEC/UL 62368-1
- MTBF 22.3 Mh

General Characteristics

- Output over voltage protection
- Input under voltage shutdown
- Over temperature protection
- Output short-circuit protection
- Monotonic start-up and shutdown
- Remote sense
- Remote control
- Output voltage adjust function
- Power good signal
- Highly automated manufacturing ensures quality
- ISO 9001/14001 certified supplier



Safety Approvals



Design for Environment



Meets requirements in high-temperature lead-free soldering processes.

Contents

Ordering Information	2
General Information	2
Safety Specification	3
Absolute Maximum Ratings	4
Electrical Specification	
6A / 0.8 – 5V	PMT 8318VS 5
EMC Specification	13
Operating Information	13
Thermal Consideration	15
Connections	15
Mechanical Information	16
Soldering Information	17
Delivery Information	18
Product Qualification Specification	19

PMT 8318VS series PoL Regulators
Input 4.5-14 V, Output up to 6 A / 30 W

28701- BMR 708 0010 Rev. B November 2018

© Flex

Ordering Information

Product program	Output
PMT 8318VS	0.8-5.5 V, 6 A / 30 W

Product number

PMT 8318VS n ₁ n ₂		
Options	n ₁	n ₂
Remote Control logic	o	
Solder bump		o

Options	Description
n ₁	Negative * P Positive
n ₂	Surface mount, with solder bump * OP Surface mount, without solder bump

Positive logic, without solder bump would be PMT 8318VSPOP.

* Standard variant (i.e. no option selected).

General Information

Reliability

The failure rate (λ) and mean time between failures (MTBF = $1/\lambda$) is calculated at max output power and an operating ambient temperature (T_A) of +25°C. Flex uses Telcordia SR-332 Issue 3 Method 1 to calculate the mean steady-state failure rate and standard deviation (σ).

Mean steady-state failure rate, λ	Std. deviation, σ
44.75 nFailures/h	15.696 nFailures/h

MTBF (mean value) for the PMT 8318VS = 22.3 Mh.

Compatibility with RoHS requirements

The products are compatible with the relevant clauses and requirements of the RoHS directive 2011/65/EU and have a maximum concentration value of 0.1% by weight in homogeneous materials for lead, mercury, hexavalent chromium, PBB and PBDE and of 0.01% by weight in homogeneous materials for cadmium.

Exemptions in the RoHS directive utilized in Flex products are found in the Statement of Compliance document.

Flex fulfills and will continuously fulfill all its obligations under regulation (EC) No 1907/2006 concerning the registration, evaluation, authorization and restriction of chemicals (REACH) as they enter into force and is through product materials declarations preparing for the obligations to communicate information on substances in the products.

Quality Statement

The products are designed and manufactured in an industrial environment where quality systems and methods like ISO 9000, Six Sigma, and SPC are intensively in use to boost the continuous improvements strategy. Infant mortality or early failures in the products are screened out and they are subjected to an ATE-based final test. Conservative design rules, design reviews and product qualifications, plus the high competence of an engaged work force, contribute to the high quality of the products.

Warranty

Warranty period and conditions are defined in Flex General Terms and Conditions of Sale.

Limitation of Liability

Flex does not make any other warranties, expressed or implied including any warranty of merchantability or fitness for a particular purpose (including, but not limited to, use in life support applications, where malfunctions of product can cause injury to a person's health or life).

© Flex 2018

The information and specifications in this technical specification is believed to be correct at the time of publication. However, no liability is accepted for inaccuracies, printing errors or for any consequences thereof. Flex reserves the right to change the contents of this technical specification at any time without prior notice.

PMT 8318VS series PoL Regulators Input 4.5-14 V, Output up to 6 A / 30 W	28701- BMR 708 0010 Rev. B November 2018
	© Flex

Safety Specification

General information

Flex Power DC/DC converters and DC/DC regulators are designed in accordance with the safety standards IEC 62368-1 and UL 62368-1 *Audio/video, information and communication technology equipment - Part 1: Safety requirements*

IEC/UL 62368-1 contains requirements to prevent injury or damage due to the following hazards:

- Electrical shock
- Electrically-caused fire
- Injury caused by hazardous substances
- Mechanically-caused injury
- Skin burn
- Radiation-caused injury

On-board DC/DC converters, Power interface modules and DC/DC regulators are defined as component power supplies. As components they cannot fully comply with the provisions of any safety requirements without “conditions of acceptability”. Clearance between conductors and between conductive parts of the component power supply and conductors on the board in the final product must meet the applicable safety requirements. Certain conditions of acceptability apply for component power supplies with limited stand-off (see Mechanical Information for further information). It is the responsibility of the installer to ensure that the final product housing these components complies with the requirements of all applicable safety standards and regulations for the final product.

Component power supplies for general use shall comply with the requirements in IEC/UL 62368-1. Product related standards, e.g. IEEE 802.3af *Power over Ethernet*, and ETS-300132-2 *Power interface at the input to telecom equipment, operated by direct current (dc)* are based on IEC/UL 60950-1 with regards to safety.

Flex Power DC/DC converters, Power interface modules and DC/DC regulators are UL 62368-1 recognized. The flammability rating for all construction parts of the products meet requirements for V-0 class material according to IEC 60695-11-10, *Fire hazard testing, test flames – 50 W* horizontal and vertical flame test methods.

Non - isolated DC/DC regulators

The DC/DC regulator output is ES1 energy source if the input source meets the requirements for ES1 according to IEC/UL 62368-1. The positive input is to be provided with a fast-acting fuse with a maximum rating of 6 A .

PMT 8318VS series PoL Regulators
 Input 4.5-14 V, Output up to 6 A / 30 W

28701- BMR 708 0010 Rev. B November 2018

© Flex

Absolute Maximum Ratings

Characteristics		min	typ	max	Unit
T_{P1}	Operating Temperature (see Thermal Consideration section)	-40		+120	°C
T_S	Storage temperature	-55		+125	°C
V_I	Input voltage	-0.3		15	V
V_{RC}	Remote Control pin voltage	-0.3		15	V
V_{adj}	Adjust pin voltage (see Operating Information section)	-0.3		6	V

Stress in excess of Absolute Maximum Ratings may cause permanent damage. Absolute Maximum Ratings, sometimes referred to as no destruction limits, are normally tested with one parameter at a time exceeding the limits in the Electrical Specification. If exposed to stress above these limits, function and performance may degrade in an unspecified manner.

Fundamental Circuit Diagram

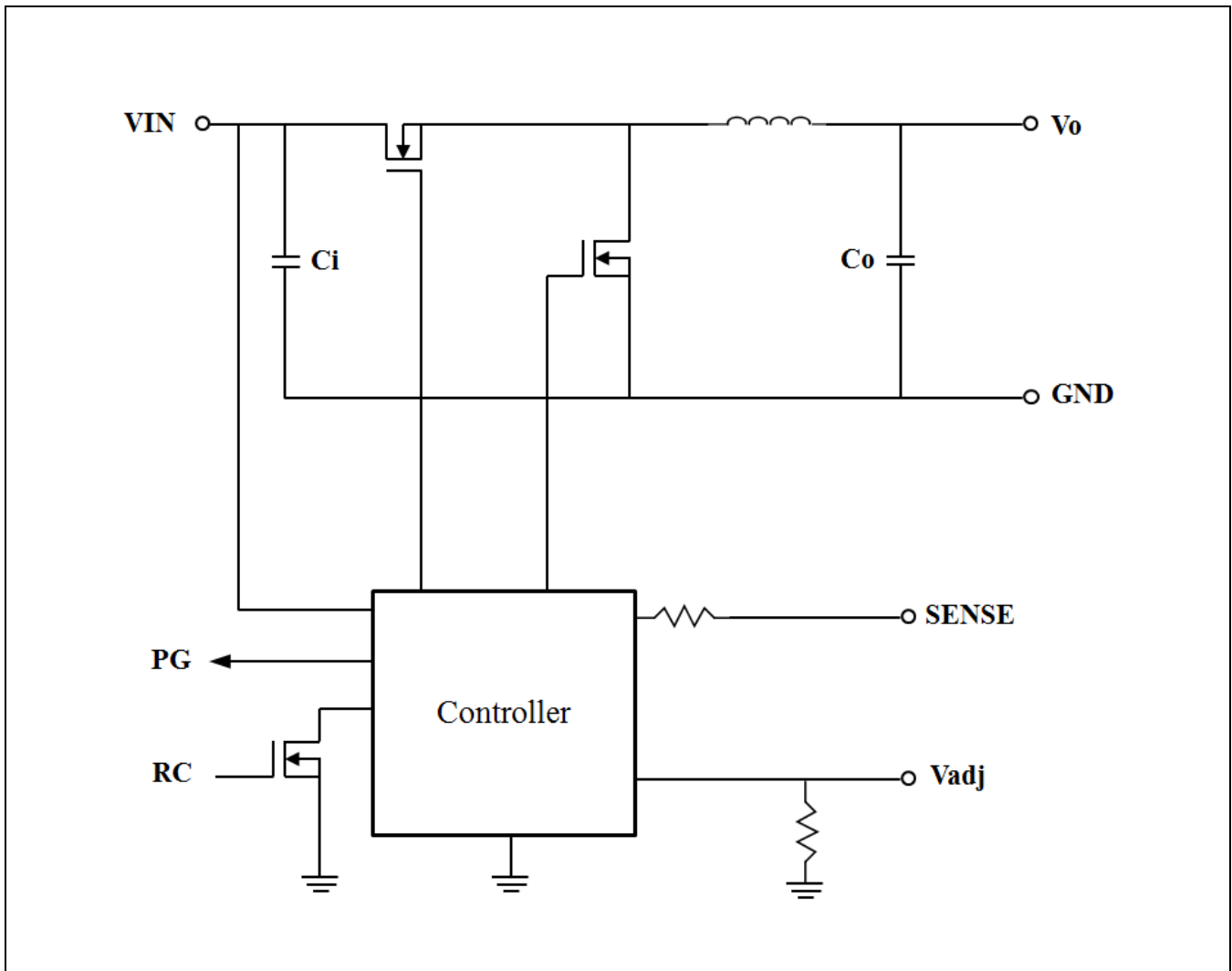

PMT 8318VS series PoL Regulators
 Input 4.5-14 V, Output up to 6 A / 30 W

28701- BMR 708 0010 Rev. B November 2018

© Flex

Electrical Specification
PMT 8318VS

$T_{P1} = -40$ to $+100^{\circ}\text{C}$, $V_I = 4.5$ to 14 V, $V_I > V_O + 1.0$ V unless otherwise specified under Conditions.
 Typical values given at: $T_{P1} = +25^{\circ}\text{C}$, $V_I = 12.0$ V, max I_O , unless otherwise specified under Conditions.
 Additional $C_{IN} = 100$ μF . See Operating Information section for selection of capacitor types.
 Sense pins are connected to the output pins.

Characteristics		Conditions	min	typ	max	Unit
V_I	Input voltage range		4.5	12.0	14.0	V
V_{in-off}	Turn-off input voltage	Decreasing input voltage	2.35		2.50	V
V_{in-on}	Turn-on input voltage	Increasing input voltage	2.55		2.75	V
P_O	Output power	$V_O = 0.8$ V	0		4.8	W
		$V_O = 1.2$ V	0		7.2	
		$V_O = 1.8$ V	0		10.8	
		$V_O = 2.5$ V	0		15	
		$V_O = 3.3$ V	0		19.8	
		$V_O = 5$ V	0		30	
η	Efficiency	$I_O = 6$ A, $V_O = 0.8$ V		80.6		%
		$I_O = 6$ A, $V_O = 1.2$ V		85.1		
		$I_O = 6$ A, $V_O = 1.8$ V		89.2		
		$I_O = 6$ A, $V_O = 2.5$ V		91.5		
		$I_O = 6$ A, $V_O = 3.3$ V		93.6		
		$I_O = 6$ A, $V_O = 5.0$ V		95.1		
P_d	Power Dissipation	$V_O = 0.8$ V, max I_O		1.2		W
		$V_O = 1.2$ V, max I_O		1.26		
		$V_O = 1.8$ V, max I_O		1.29		
		$V_O = 2.5$ V, max I_O		1.35		
		$V_O = 3.3$ V, max I_O		1.42		
		$V_O = 5$ V, max I_O		1.51		
P_{ii}	Input idling power	$I_O = 0$ A, $V_O = 0.8$ V		0.22		W
		$I_O = 0$ A, $V_O = 1.2$ V		0.23		
		$I_O = 0$ A, $V_O = 1.8$ V		0.28		
		$I_O = 0$ A, $V_O = 2.5$ V		0.34		
		$I_O = 0$ A, $V_O = 3.3$ V		0.4		
		$I_O = 0$ A, $V_O = 5$ V		0.5		
P_{RC}	Input standby power	turned off with RC		1		mW
I_S	Static Input current	$V_I = 4.5 - 14.0$ V, 0-100% of max I_O			6.5	A
f_s	Switching frequency			600		kHz

V_{O1}	Output voltage Set-point	Use external resistor with 0.5% tolerance to set output voltage	-1.5		+1.5	% $V_{O, set}$
V_O	Output voltage tolerance band	Overall operating input voltage, resistive load, and temperature conditions until end of life	-2.5		+2.5	% $V_{O, set}$
	Output voltage adjust range		0.8		5.5	V
	Line regulation	max I_O	-0.4		+0.4	% $V_{O, set}$
	Load regulation	$V_I = 12$ V, 0-100 % of max I_O	-0.4		+0.4	% $V_{O, set}$
	V_{tr}	Load transient voltage deviation	Load step 50-100-50% of max I_O $di/dt = 1$ A/ μs			± 150
t_{tr}	Load transient recovery time				100	μs
t_r	Ramp-up time (from 10-90% of V_{O1})	$I_O = 0$		3.0		ms
t_s	Start-up time (from V_I connection to 90% of V_{O1})		5.6		ms	
t_{RC}	RC start-up time (from RC on to 90% of V_{O1})		3.0		ms	

PMT 8318VS series PoL Regulators
 Input 4.5-14 V, Output up to 6 A / 30 W

28701- BMR 708 0010 Rev. B November 2018

© Flex

I_O	Output current		0	6	A
I_{lim}	Current limit threshold	$T_A < \max T_A$	10.5		A
I_{sc}	Short circuit current	See Note 1	4.3		A
V_{Oac}	Output ripple & noise	See ripple & noise section, max I_O . See Note 2	40	100	mVp-p
PG	Power good threshold		92		% V_O
OVP	Output voltage over voltage protection threshold		108		% V_O
RC	Trigger level	Positive Logic	Logic high voltage threshold (On)	0.7	V
			Logic low voltage threshold (Off)	0.5	
		Negative Logic	Logic high voltage threshold (Off)	2.5	
			Logic low voltage threshold (On)	0.6	

Note 1: Hiccup mode, RMS value, see Operating Information section

Note 2: Cout; 10 μ F // 0.1 μ F ceramic capacitors

PMT 8318VS series PoL Regulators
 Input 4.5-14 V, Output up to 6 A / 30 W

28701- BMR 708 0010 Rev. B November 2018

© Flex

Typical Characteristics

0.8 V, 6 A / 4.8 W, $R_{adj} = 28.28 \text{ k}\Omega$

PMT 8318VS

Efficiency

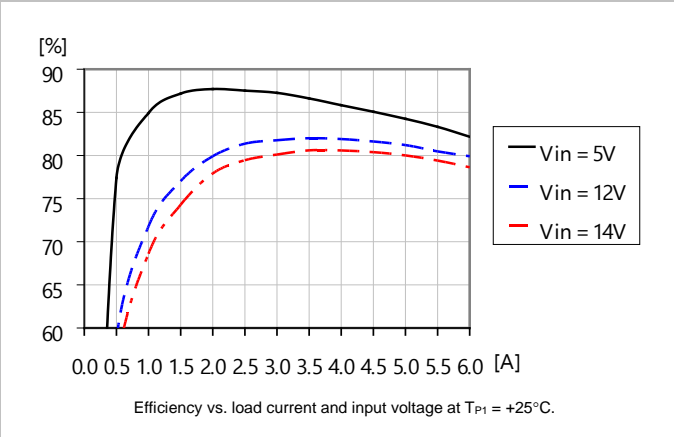

Current Derating

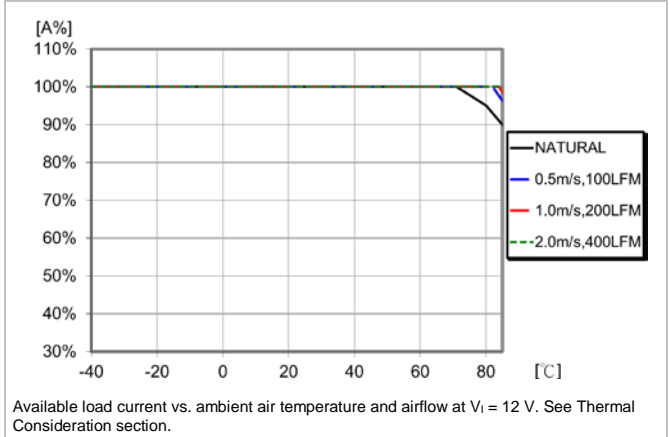

Output Ripple & Noise

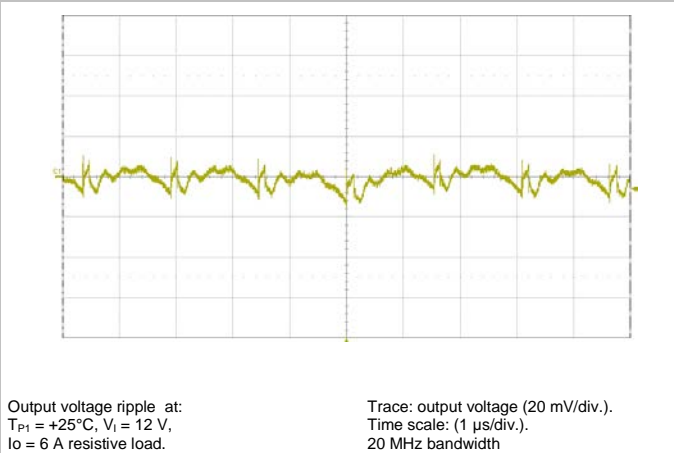

Output Load Transient Response

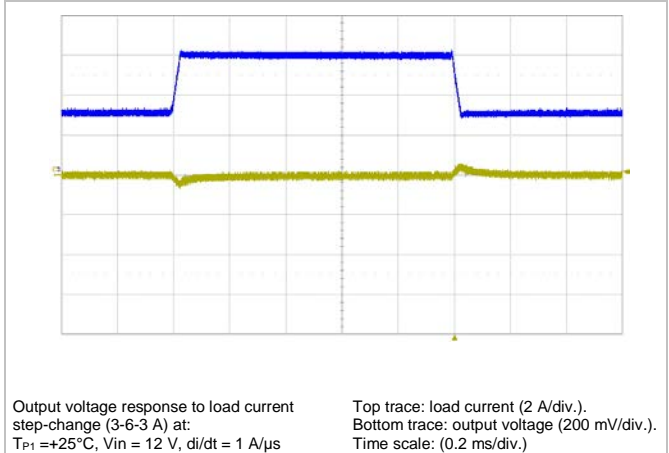

Start-up with RC

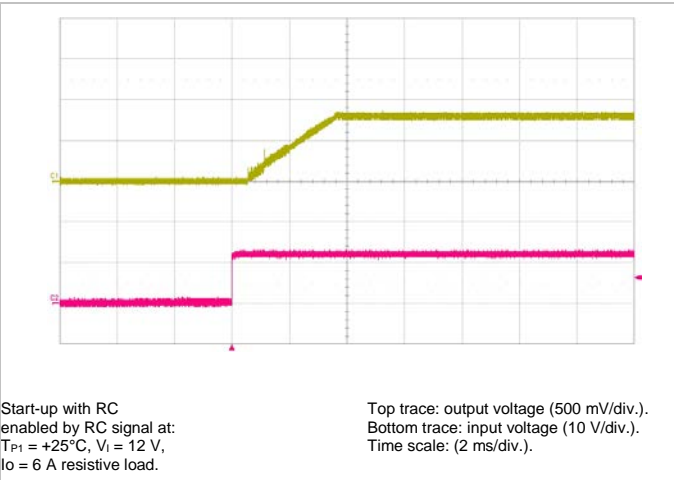

Start-up with input voltage

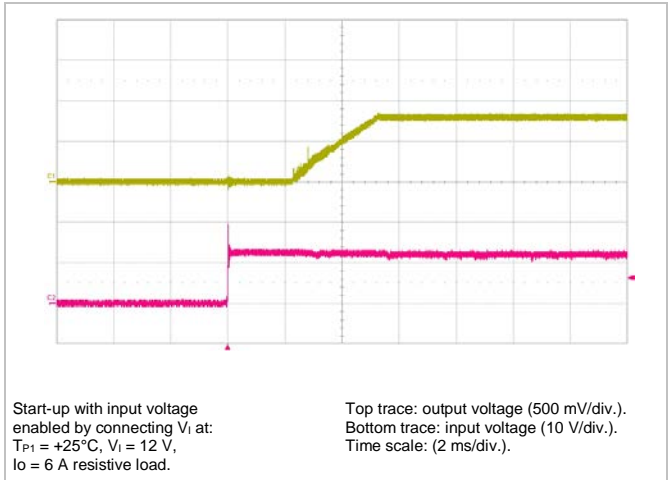

PMT 8318VS series PoL Regulators
 Input 4.5-14 V, Output up to 6 A / 30 W

28701- BMR 708 0010 Rev. B November 2018

© Flex

Typical Characteristics

1.2 V, 6 A / 7.2 W, $R_{adj} = 9.65 \text{ k}\Omega$

PMT 8318VS

Efficiency

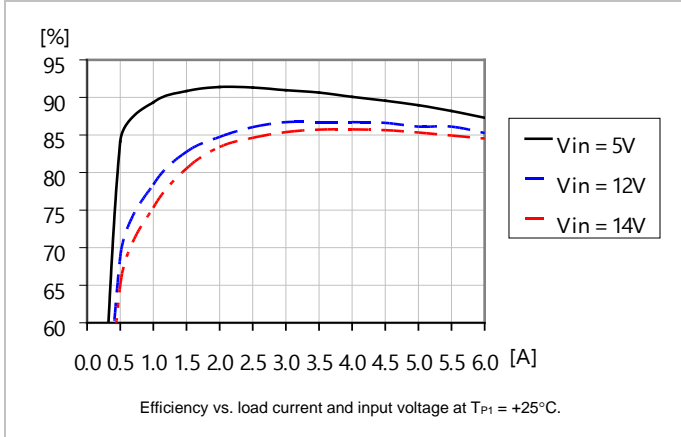

Current Derating

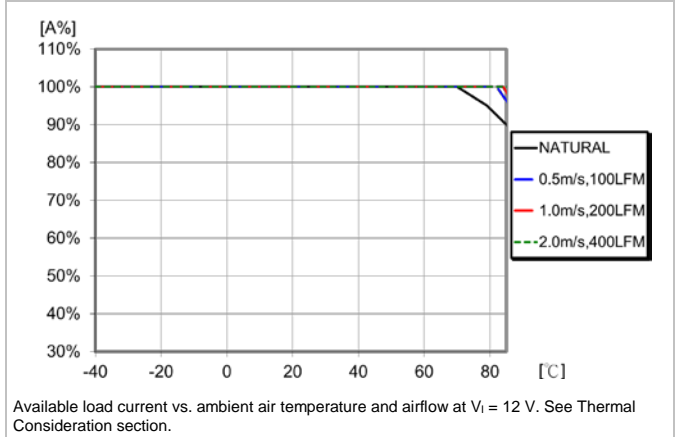

Output Ripple & Noise

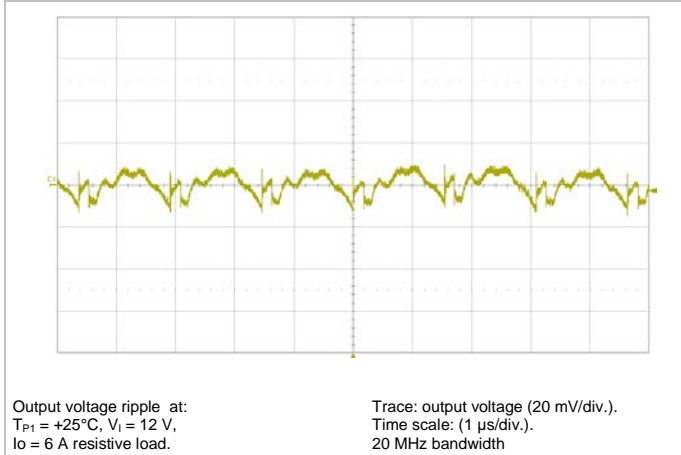

Output Load Transient Response

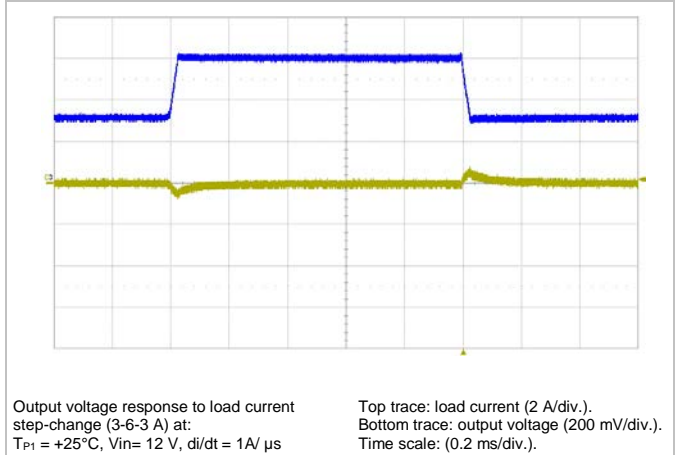

Start-up with RC

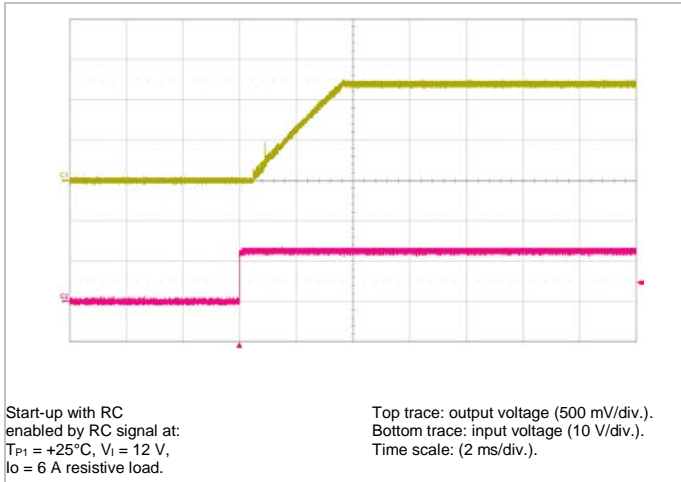

Start-up with input voltage

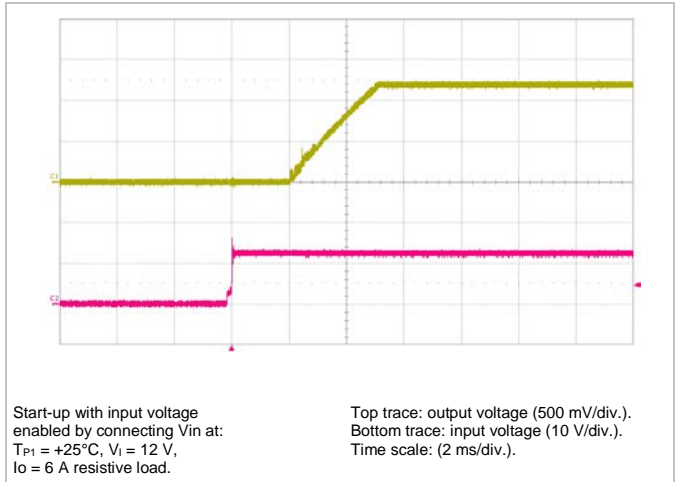

PMT 8318VS series PoL Regulators
 Input 4.5-14 V, Output up to 6 A / 30 W

28701- BMR 708 0010 Rev. B November 2018

© Flex

Typical Characteristics

1.8 V, 6 A / 10.8 W, $R_{adj} = 4.87 \text{ k}\Omega$

PMT 8318VS

Efficiency

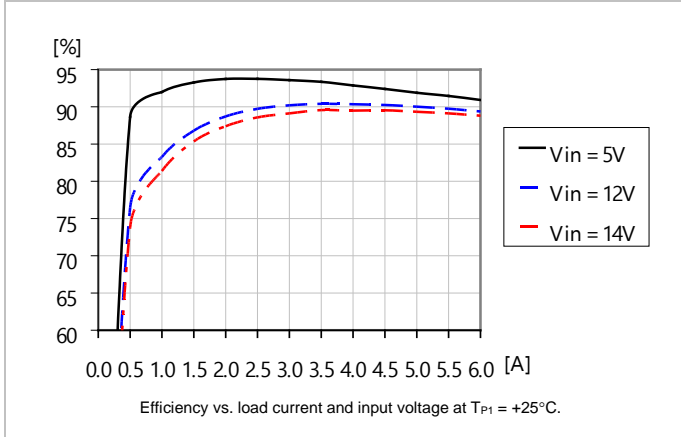

Current Derating

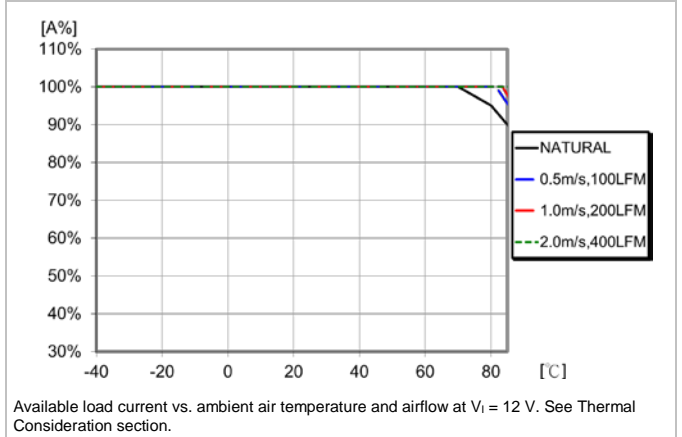

Output Ripple & Noise

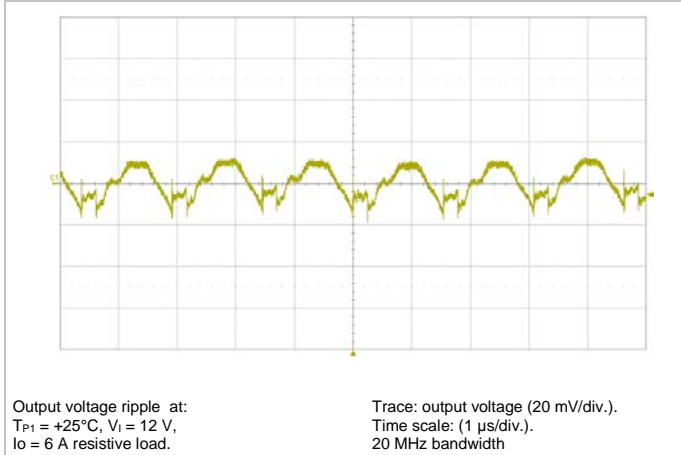

Output Load Transient Response

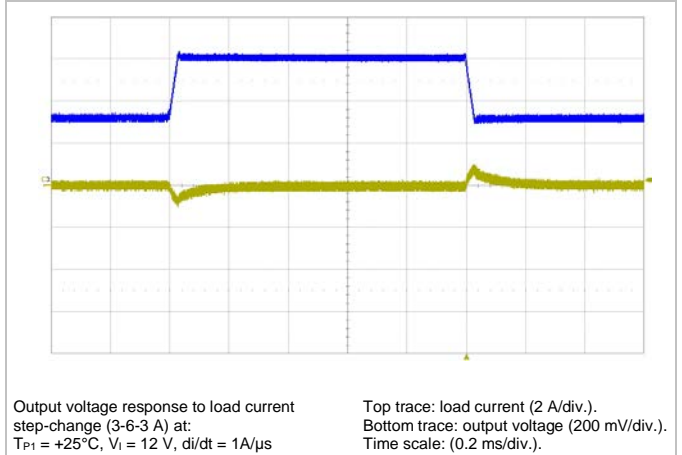

Start-up with RC

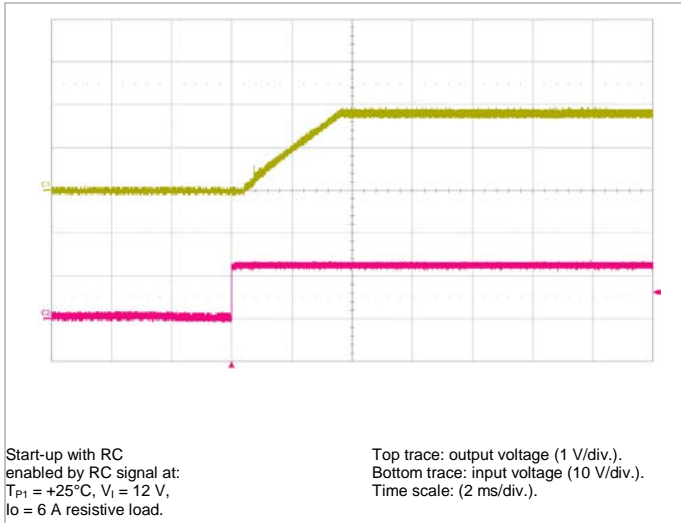

Start-up with input voltage

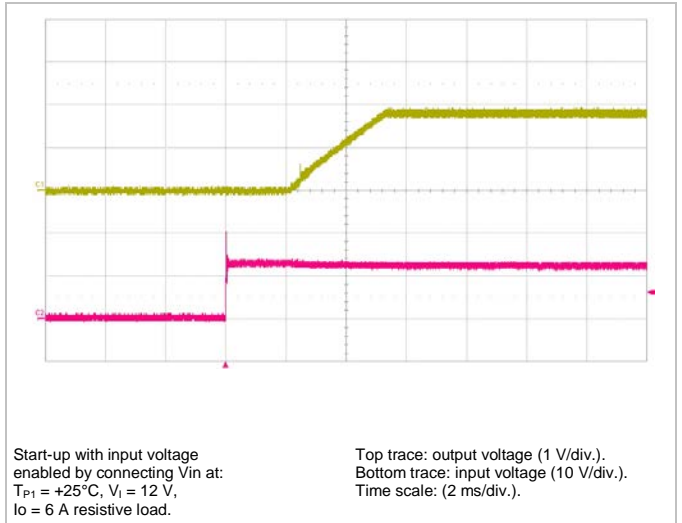

PMT 8318VS series PoL Regulators
 Input 4.5-14 V, Output up to 6 A / 30 W

28701- BMR 708 0010 Rev. B November 2018
 © Flex

Typical Characteristics
 2.5 V, 6 A / 15 W, $R_{adj} = 3.09\text{ k}\Omega$

PMT 8318VS

Efficiency

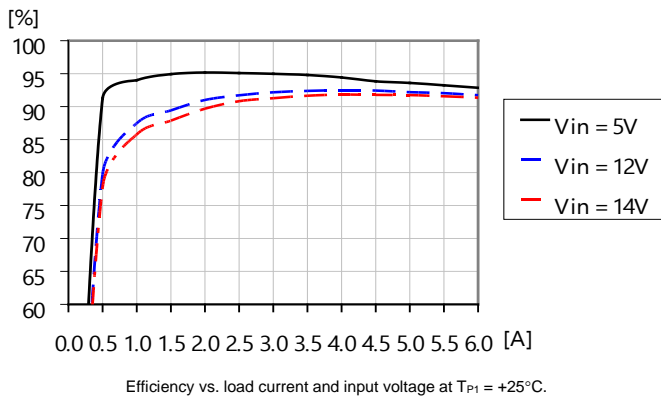

Current Derating

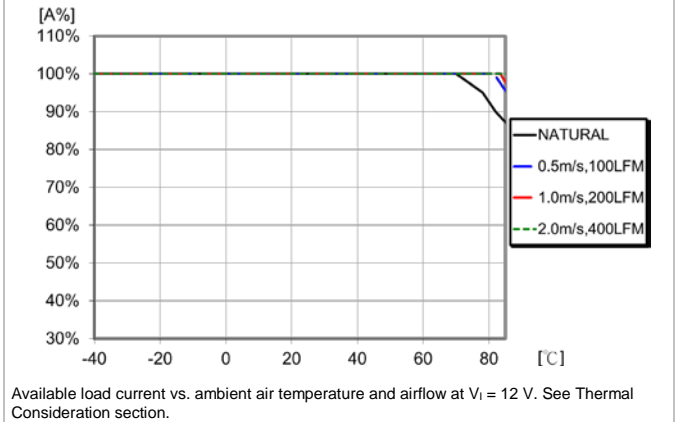

Output Ripple & Noise

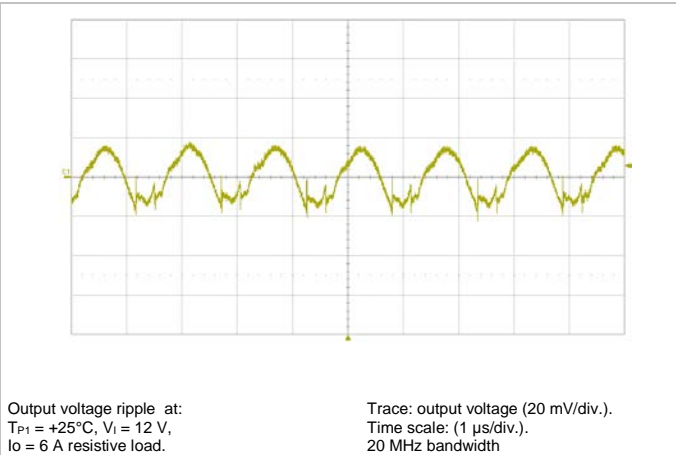

Output Load Transient Response

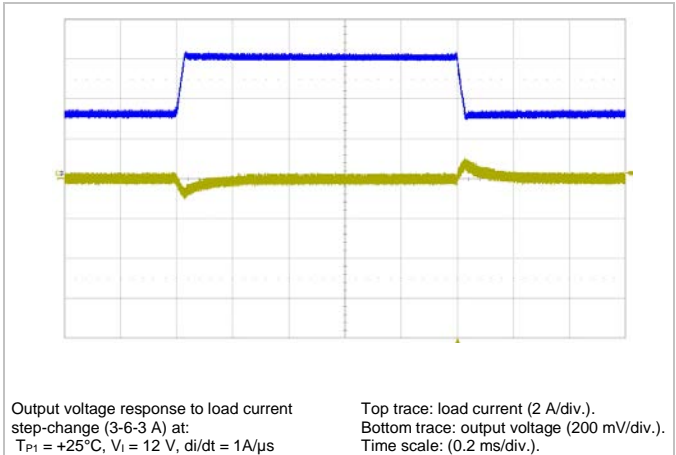

Start-up with RC

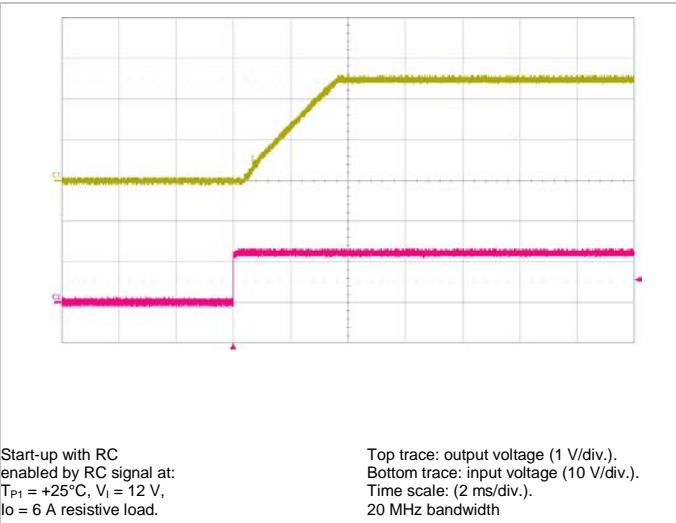

Start-up with input voltage

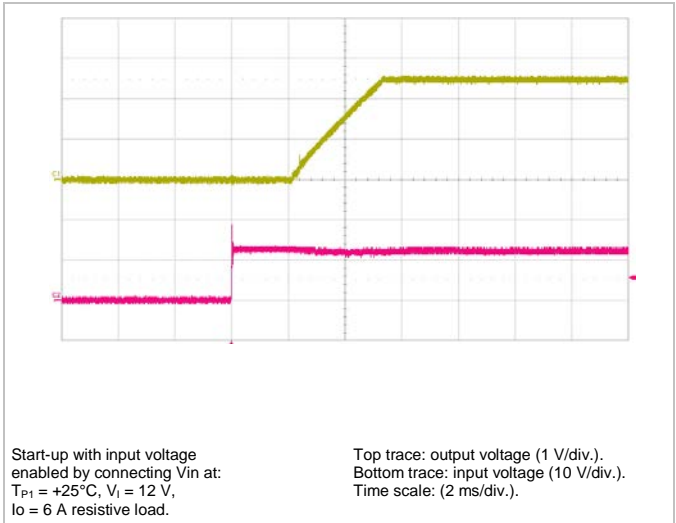

PMT 8318VS series PoL Regulators
 Input 4.5-14 V, Output up to 6 A / 30 W

28701- BMR 708 0010 Rev. B November 2018
 © Flex

Typical Characteristics

PMT 8318VS

3.3 V, 6 A / 19.8 W, $R_{adj} = 2.18 \text{ k}\Omega$

Efficiency

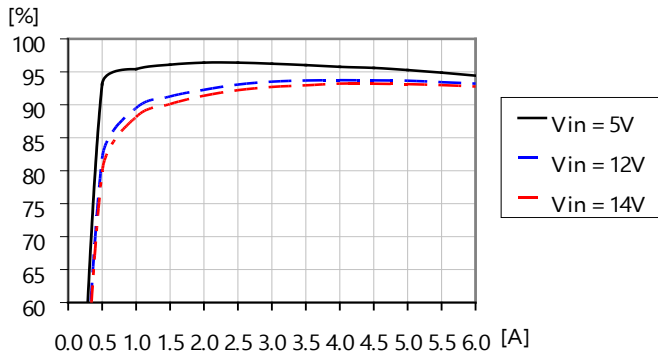

Efficiency vs. load current and input voltage at $T_{P1} = +25^\circ\text{C}$.

Current Derating

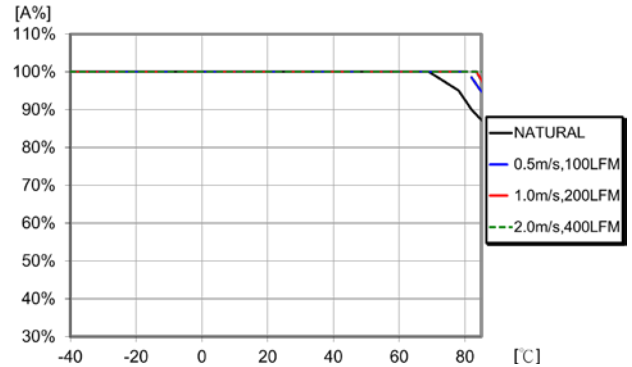

Available load current vs. ambient air temperature and airflow at $V_I = 12 \text{ V}$. See Thermal Consideration section.

Output Ripple & Noise

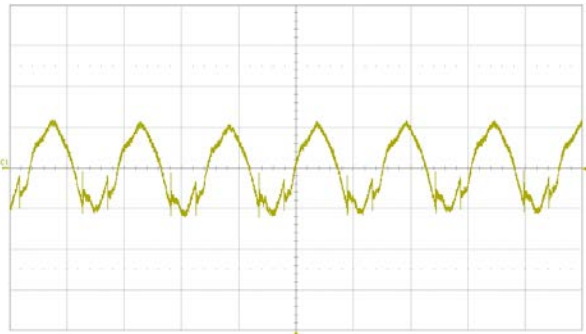

Output voltage ripple at:
 $T_{P1} = +25^\circ\text{C}$, $V_I = 12 \text{ V}$,
 $I_O = 6 \text{ A}$ resistive load.

Trace: output voltage (20 mV/div.).
 Time scale: (1 μs /div.).
 20 MHz bandwidth

Output Load Transient Response

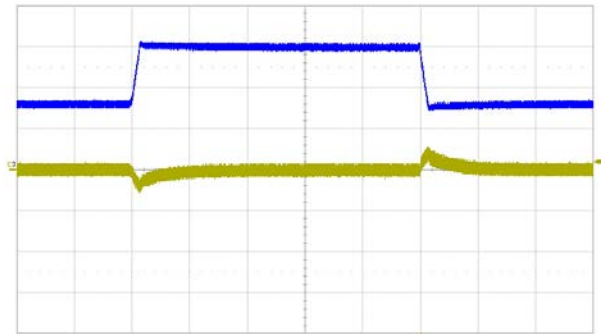

Output voltage response to load current step-change (3-6-3 A) at:
 $T_{P1} = +25^\circ\text{C}$, $V_I = 12 \text{ V}$, $di/dt = 1 \text{ A}/\mu\text{s}$

Top trace: load current (2 A/div.).
 Bottom trace: output voltage (200 mV/div.).
 Time scale: (0.2 ms/div.).

Start-up with RC

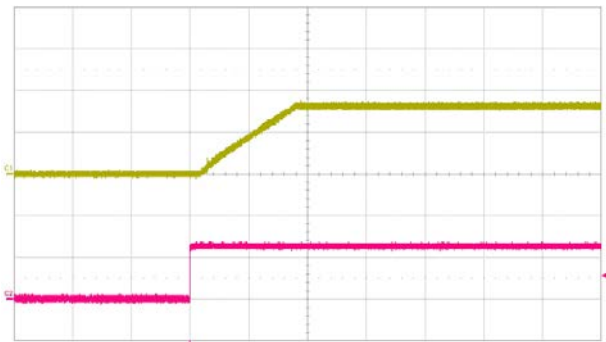

Start-up with RC enabled by RC signal at:
 $T_{P1} = +25^\circ\text{C}$, $V_I = 12 \text{ V}$,
 $I_O = 6 \text{ A}$ resistive load.

Top trace: output voltage (2 V/div.).
 Bottom trace: input voltage (10 V/div.).
 Time scale: (2 ms/div.).

Start-up with input voltage

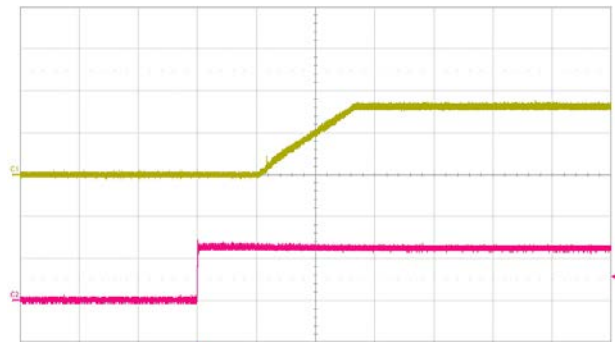

Start-up with input voltage enabled by connecting V_{in} at:
 $T_{P1} = +25^\circ\text{C}$, $V_I = 12 \text{ V}$,
 $I_O = 6 \text{ A}$ resistive load.

Top trace: output voltage (2 V/div.).
 Bottom trace: input voltage (10 V/div.).
 Time scale: (2 ms/div.).

PMT 8318VS series PoL Regulators
 Input 4.5-14 V, Output up to 6 A / 30 W

28701- BMR 708 0010 Rev. B November 2018
 © Flex

Typical Characteristics
5.0 V, 6 A / 30 W, $R_{adj} = 1.34 \text{ k}\Omega$

PMT 8318VS

Efficiency

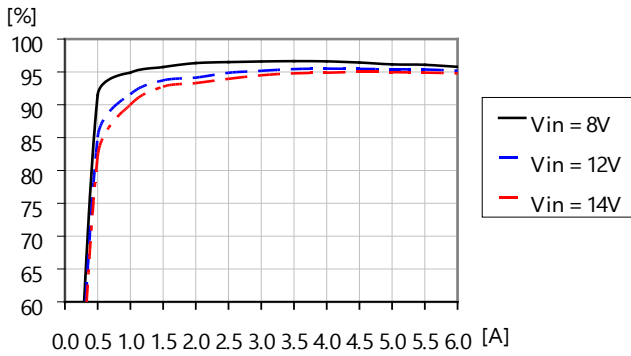

Efficiency vs. load current and input voltage at $T_{P1} = +25^\circ\text{C}$.

Current Derating

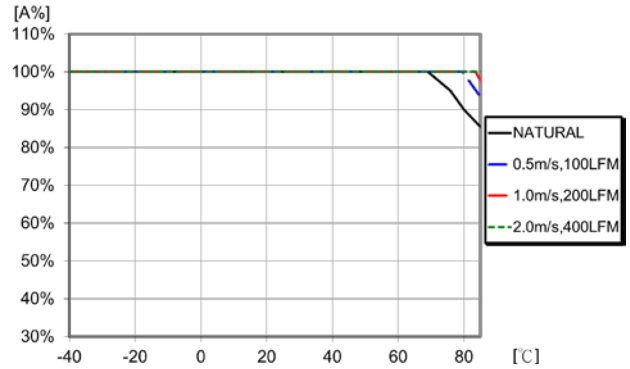

Available load current vs. ambient air temperature and airflow at $V_1 = 12 \text{ V}$. See Thermal Consideration section.

Output Ripple & Noise

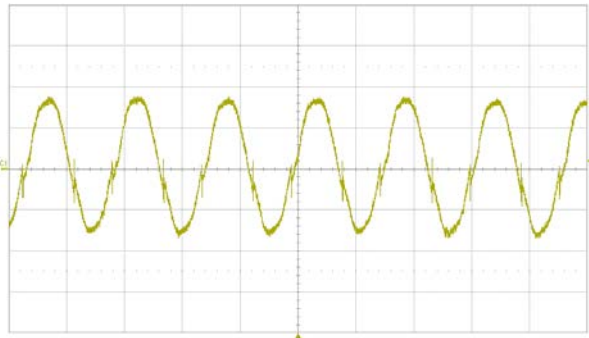

Output voltage ripple at:
 $T_{P1} = +25^\circ\text{C}$, $V_1 = 12 \text{ V}$,
 $I_o = 6 \text{ A}$ resistive load.

Trace: output voltage (20 mV/div.).
 Time scale: (1 µs/div.).
 20 MHz bandwidth

Output Load Transient Response

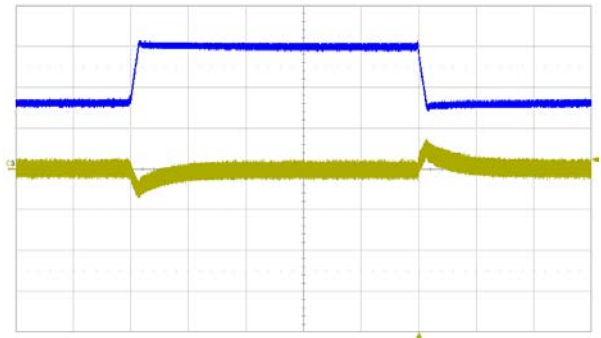

Output voltage response to load current step-change (3-6-3 A) at:
 $T_{P1} = +25^\circ\text{C}$, $V_1 = 12 \text{ V}$, $di/dt = 1 \text{ A}/\mu\text{s}$

Top trace: load current (2 A/div.).
 Bottom trace: output voltage (200 mV/div.).
 Time scale: (0.2 ms/div.).

Start-up with RC

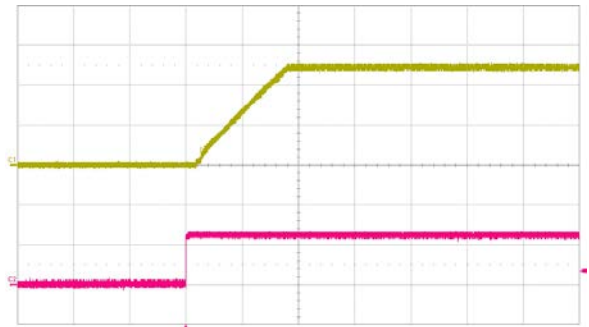

Start-up with RC enabled by RC signal at:
 $T_{P1} = +25^\circ\text{C}$, $V_1 = 12 \text{ V}$,
 $I_o = 6 \text{ A}$ resistive load.

Top trace: output voltage (2 V/div.).
 Bottom trace: input voltage (10 V/div.).
 Time scale: (2 ms/div.).

Start-up with input voltage

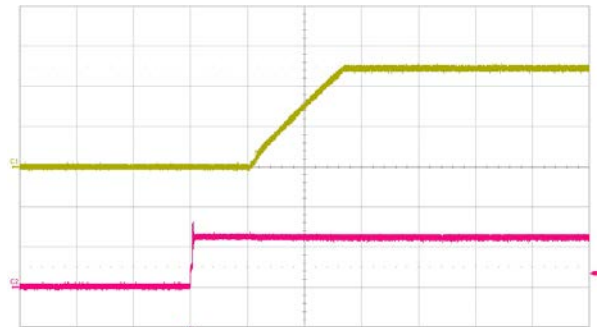

Start-up with input voltage enabled by connecting V_{in} at:
 $T_{P1} = +25^\circ\text{C}$, $V_1 = 12 \text{ V}$,
 $I_o = 6 \text{ A}$ resistive load.

Top trace: output voltage (2 V/div.).
 Bottom trace: input voltage (10 V/div.).
 Time scale: (2 ms/div.).

PMT 8318VS series PoL Regulators
Input 4.5-14 V, Output up to 6 A / 30 W

28701- BMR 708 0010 Rev. B November 2018

© Flex

EMC Specification

Layout recommendations

The radiated EMI performance of the product will depend on the PWB layout and ground layer design. It is also important to consider the stand-off of the product. If a ground layer is used, it should be connected to the output of the product and the equipment ground or chassis.

A ground layer will increase the stray capacitance in the PWB and improve the high frequency EMC performance.

Output ripple and noise

Output ripple and noise measured according to figure below. See Design Note 022 for detailed information.

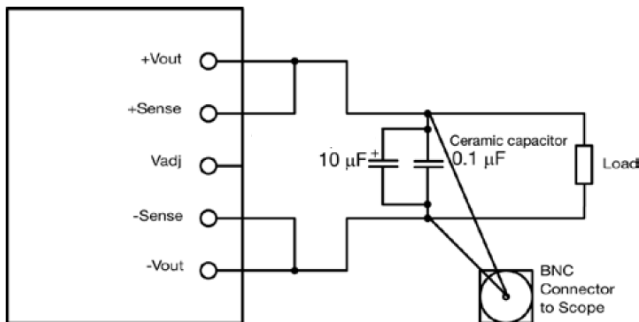

Output ripple and noise test setup

The module is designed for low ripple voltage at the module output and will meet the maximum output ripple specification with 0.1µF ceramic and 10µF ceramic capacitors at the output of the module.

Operating information

Input Voltage

The input voltage range 4.5 to 14 Vdc makes the product easy to use in intermediate bus applications when powered by a non-regulated bus converter or a regulated bus converter.

Turn-off Input Voltage

The products monitor the input voltage and will turn on and turn off at predetermined levels.

Remote Control (RC)

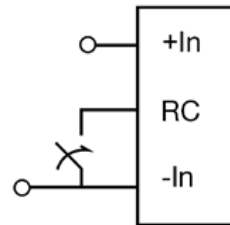

The products are fitted with a remote control function referenced to the primary negative input connection (-In or GND), with negative and positive logic options available. The RC function allows the product to be turned on/off by an external device like a semiconductor or mechanical switch.

For the positive logic option, the product turns on when RC is high and off when RC is low. For the negative logic option, the product turns off when RC is high and on when RC is low. The on/off signal is always referenced to ground (negative input). For either logic option, leaving the RC pin open will turn the product on when input voltage is present. Refer to the Electrical Characteristics table for RC logic high and low thresholds.

Input and Output impedance

The impedance of both the input source and the load will interact with the impedance of the product. It is important that the input source has low characteristic impedance. The performance in some applications can be enhanced by addition of external capacitance as described under External Capacitors. The capacitor is not required when powering the product from an input source with an inductance below 10 µH.

External Capacitors

An input capacitance should be placed directly adjacent to the input pin of the module to minimize input ripple voltage and ensure module stability.

To minimize input voltage ripple, ceramic capacitors are recommended at the input of the module. The input capacitance shall be one 10 µF ceramic capacitor with one 100 µF electrolytic capacitor or two 22 µF ceramic capacitors.

PMT 8318VS series PoL Regulators
 Input 4.5-14 V, Output up to 6 A / 30 W

28701- BMR 708 0010 Rev. B November 2018

© Flex

When powering loads with significant dynamic current requirements, the voltage regulation at the point of load can be improved by addition of decoupling capacitors at the load. The most effective technique is to locate low ESR ceramic and electrolytic capacitors as close to the load as possible, using several parallel capacitors to lower the effective ESR. The ceramic capacitors will handle high-frequency dynamic load changes while the electrolytic capacitors are used to handle low frequency dynamic load changes. It is equally important to use low resistance and low inductance PWB layouts and cabling.

External capacitors will become part of the product's control loop. The control loop is optimized for a wide range of external capacitance and is designed to operate stably with the additional capacitance.

For further information please contact your local Flex representative.

Output Voltage Adjust (V_{adj})

The products have an Output Voltage Adjust pin (V_{adj}). The output voltage of the module can be adjusted to any voltage from 0.8 V to 5.5 V by connecting a resistor between the V_{adj} and GND pins of the module. The output voltage can only be set within the set point area defined in figure 1.

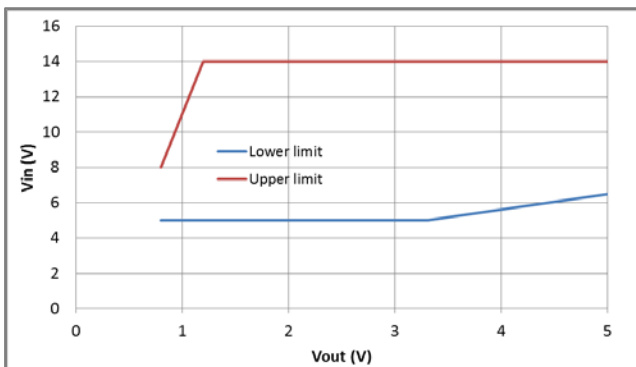

Figure 1. Output Voltage vs. Input voltage showing limits where the output can be set for different input voltages.

To calculate the value of the V_{adj} resistor, R_{adj} for a desired output voltage, use the following equation:

$$R_{adj} = 5.91 / (V_o - 0.591)$$

R_{adj} is the resistance of the external resistor in k Ω .
 V_o is the desired output voltage.

Table 1 provides ideal R_{adj} values required for some common output voltages.

Table 1. V_o Setting

V_o (V)	R_{adj} (k Ω)
0.8	28.28
1.0	14.45
1.1	11.61
1.2	9.704
1.5	6.502
1.8	4.888
2.5	3.096
3.3	2.182
5.0	1.340

By choosing R_{adj} with $\pm 0.5\%$ tolerance and TC of ± 100 ppm, an overall output voltage tolerance of $\pm 2.5\%$ can be achieved as specified in Electrical Characteristics.

Remote Sense

The regulators have Remote Sense feature that can be used to compensate for voltage drops due to parasitic impedance between output and the load.

When Remote Sense feature is not used, connect the SENSE pins to the Output pins.

Over Temperature Protection (OTP)

The regulators are protected from thermal overload by an internal over temperature shutdown circuit. When the T_{P1} temperature exceeds 130°C the regulator will shut down. The product will resume normal operation automatically when the temperature has dropped $>10^\circ\text{C}$ below the temperature threshold.

Monotonic Startup and Shutdown

The regulators have monotonic start-up and shutdown behavior for any combination of rated input voltage, output current and operating temperature range.

Power Good

The product provides a Power Good (PGOOD) signal that is implemented with an open-drain output to indicate that the output voltage is within the regulation limits of the power module. When the output voltage rises above the over-voltage threshold or drops below the under-voltage Threshold, the PGOOD output is pulled to ground after a delay of 12 μs . The over-voltage or under-voltage condition must exist for more than 10 μs for PGOOD to become active. The PGOOD output also becomes active if a thermal overload condition is detected.

PMT 8318VS series PoL Regulators
 Input 4.5-14 V, Output up to 6 A / 30 W

28701- BMR 708 0010 Rev. B November 2018
 © Flex

Thermal Consideration

General

The products are designed to operate in different thermal environments and sufficient cooling must be provided to ensure reliable operation.

For products mounted on a PWB without a baseplate attached, cooling is achieved mainly by conduction, from the pins to the host board, and convection, which is dependant on the airflow across the product. Increased airflow enhances the cooling of the product. The Output Current Derating graph found in the Typical Characteristics section for each model provides the available output current vs. ambient air temperature at $V_I = 12\text{ V}$.

The product is tested on a 110 x 50 mm, 70 μm (2 oz), 4-layer test board mounted vertically in a wind tunnel with a cross-section of 260 x 75 mm.

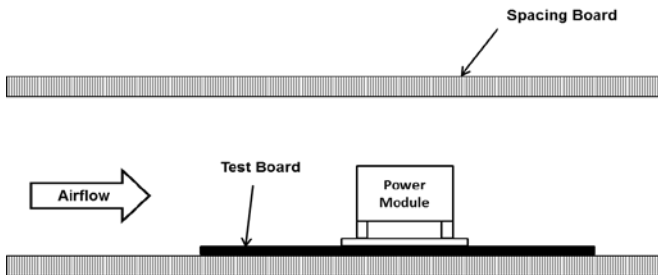

Definition of product operating temperature

The product operating temperatures is used to monitor the temperature of the product, and proper thermal conditions can be verified by measuring the temperature at positions P1. The temperature at this position (T_{P1}) should not exceed the maximum temperatures in the table below. Temperature above maximum T_{P1} , measured at the reference point P1 are not allowed and may cause permanent damage.

Position	Designation	Max Temp.
P1	Reference point	$T_{P1}=120^{\circ}\text{C}$

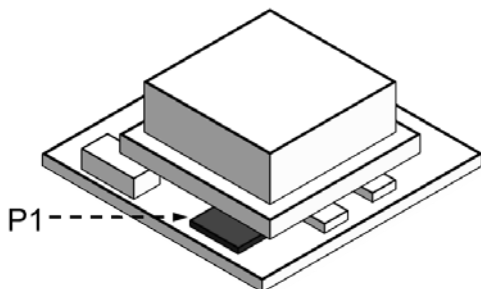

Connections

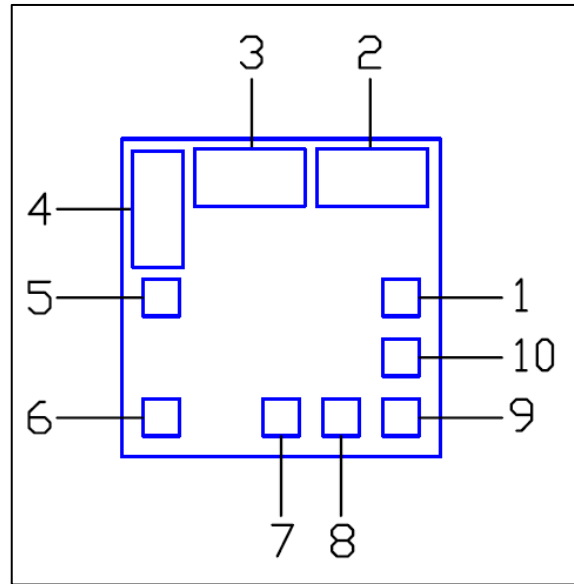

Pin	Designation	Function
1	RC	Remote control
2	+In	Positive input
3	GND	Ground pin
4	+Out	Positive output
5	SENSE	Sense pin
6	V_{adj}	Output voltage adjust
7	GND	Ground pin
8	NC	Not connected
9	NC	Not connected
10	PGOOD	Power good signal

PMT 8318VS series PoL Regulators
 Input 4.5-14 V, Output up to 6 A / 30 W

28701- BMR 708 0010 Rev. B November 2018
 © Flex

Mechanical Information

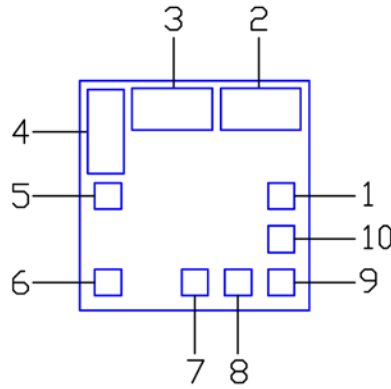
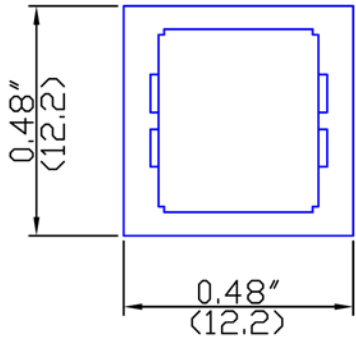

with solder bump

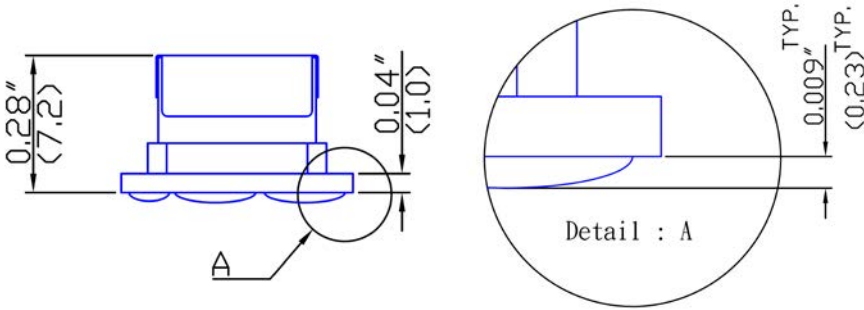

Pin	Function
1	RC
2	+In
3	GND
4	+Out
5	SENSE
6	V _{adj}
7	GND
8	NC
9	NC
10	PGOOD

without solder bump

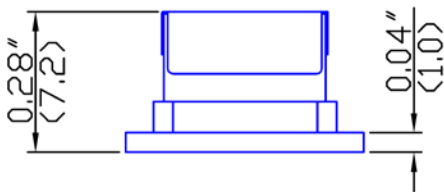

NOTE:
 Material: Solder bumps SAC305
 All dimensions in inches (mm).
 Tolerance .xx = ±0.02"
 .xxx = ±0.010"

PMT 8318VS series PoL Regulators
 Input 4.5-14 V, Output up to 6 A / 30 W

28701- BMR 708 0010 Rev. B November 2018
 © Flex

Soldering Information - Surface Mounting

The surface mount product is intended for forced convection or vapor phase reflow soldering in SnPb or Pb-free processes.

The reflow profile should be optimised to avoid excessive heating of the product. It is recommended to have a sufficiently extended preheat time to ensure an even temperature across the host PCB and it is also recommended to minimize the time in reflow.

A no-clean flux is recommended to avoid entrapment of cleaning fluids in cavities inside the product or between the product and the host board, since cleaning residues may affect long time reliability and isolation voltage.

General reflow process specifications		SnPb eutectic	Pb-free
Average ramp-up ($T_{PRODUCT}$)		3°C/s max	3°C/s max
Typical solder melting (liquidus) temperature	T_L	183°C	221°C
Minimum reflow time above T_L		30 s	30 s
Minimum pin temperature	T_{PIN}	210°C	235°C
Peak product temperature	$T_{PRODUCT}$	225°C	260°C
Average ramp-down ($T_{PRODUCT}$)		6°C/s max	6°C/s max
Maximum time 25°C to peak		6 minutes	8 minutes

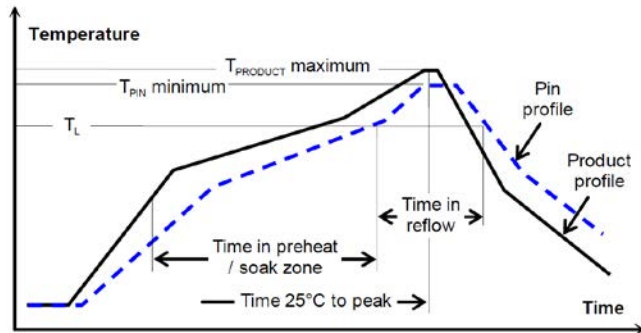

Minimum Pin Temperature Recommendations

Pin number 3 are chosen as reference location for the minimum pin temperature recommendation since these will likely be the coolest solder joint during the reflow process.

SnPb solder processes

For SnPb solder processes, a pin temperature (T_{PIN}) in excess of the solder melting temperature, (T_L , 183°C for Sn63Pb37) for more than 30 seconds and a peak temperature of 210°C is recommended to ensure a reliable solder joint.

For dry packed products only: depending on the type of solder paste and flux system used on the host board, up to a recommended maximum temperature of 245°C could be used, if the products are kept in a controlled environment (dry pack handling and storage) prior to assembly.

Lead-free (Pb-free) solder processes

For Pb-free solder processes, a pin temperature (T_{PIN}) in excess of the solder melting temperature (T_L , 217 to 221°C for SnAgCu solder alloys) for more than 30 seconds and a peak temperature of 235°C on all solder joints is recommended to ensure a reliable solder joint.

Maximum Product Temperature Requirements

Top of the product PCB near pin 2 or 4 is chosen as reference locations for the maximum (peak) allowed product temperature ($T_{PRODUCT}$) since these will likely be the warmest part of the product during the reflow process.

SnPb solder processes

For SnPb solder processes, the product is qualified for MSL 1 according to IPC/JEDEC standard J-STD-020C.

During reflow $T_{PRODUCT}$ must not exceed 225 °C at any time.

Pb-free solder processes

For Pb-free solder processes, the product is qualified for MSL 3 according to IPC/JEDEC standard J-STD-020C.

During reflow $T_{PRODUCT}$ must not exceed 260 °C at any time.

Dry Pack Information

Surface mounted versions of the products are delivered in standard moisture barrier bags according to IPC/JEDEC standard J-STD-033 (Handling, packing, shipping and use of moisture/reflow sensitivity surface mount devices).

Using products in high temperature Pb-free soldering processes requires dry pack storage and handling. In case the products have been stored in an uncontrolled environment and no longer can be considered dry, the modules must be baked according to J-STD-033.

Thermocoupler Attachment

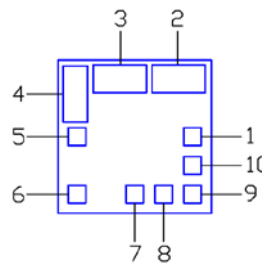

Top of PWB near pin 2 or 4 for measurement of maximum product temperature, $T_{PRODUCT}$.

Pin 3 for measurement of minimum Pin (solder joint) temperature T_{PIN} .

PMT 8318VS series PoL Regulators
 Input 4.5-14 V, Output up to 6 A / 30 W

28701- BMR 708 0010 Rev. B November 2018

© Flex

Surface Mount Assembly and Repair

The products require particular care during assembly since the pads are hidden between the host board and the product's PCB. Special procedures are required for successful rework of these products.

Assembly

Automatic pick and place equipment should be used to mount the product on the host board. The use of a vision system, utilizing the fiducials on the bottom side of the product, will ensure adequate accuracy. Manual mounting of solder bump products is not recommended.

This module is **not** recommended for assembly on the bottom side of a customer board. If such an assembly is attempted, components may fall off the module during the second reflow process.

Repair

For a successful repair (removal and replacement) of the product, a dedicated rework system should be used. The rework system should preferably utilize a reflow station and a bottom side heater might also be needed for the operation.

The product is an open frame design with a pick up surface on a large central component (in this case the choke). This pick up surface can be used for removal of the module provided that it is glued against module PCB before removal to prevent it from separating from the module PCB.

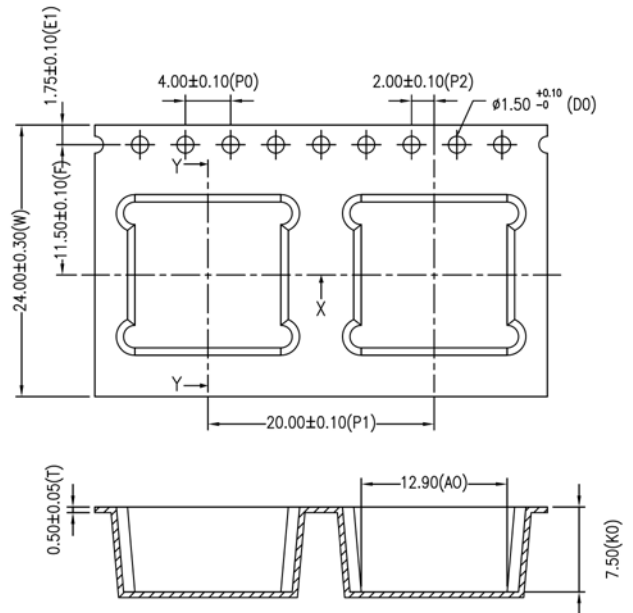

Delivery Package Information

The products are delivered in antistatic carrier tape (EIA 481 standard).

Carrier Tape Specifications	
Material	PS, antistatic
Surface resistance	$<10^6$ Ohm/square
Bakeability	The tape is not bakable
Tape width, W	24 mm [0.94 inch]
Pocket pitch, P ₁	20 mm [0.79 inch]
Pocket depth, K ₀	7.5 mm [0.295 inch]
Reel diameter	330 mm [13 inch]
Reel capacity	400 products/reel
Reel weight	1004 g/full reel

PMT 8318VS series PoL Regulators
Input 4.5-14 V, Output up to 6 A / 30 W

28701- BMR 708 0010 Rev. B November 2018

© Flex

Product Qualification Specification

Characteristics			
External visual inspection	IPC-A-610		
Change of temperature (Temperature cycling)	IEC 60068-2-14 Na	Temperature range Number of cycles Dwell/transfer time	-55 to 105°C 20 30 min/3 min
Cold (in operation)	IEC 60068-2-1	Temperature T _A Duration	-45°C 72 h
Damp heat	IEC 60068-2-30	Temperature Humidity Duration	45°C 95% 72 h
Dry heat	IEC 60068-2-2 Bd	Temperature Duration	125°C 1000 h
Mechanical shock	IEC 60068-2-27 Ea	Peak acceleration Duration	200 g 11 ms
Vibration	EN 61373:1999	Frequency Axis Duration	5 to 150 Hz X, Y, Z 5 h
Moisture reflow sensitivity	J-STD-020C	Level 3 (Pb Free)	260°C
Operational life test	MIL-STD-202G, method 108A	Duration	1000 h
Robustness of terminations	IEC 60068-2-21 Test Ue1	Surface mount products	All leads
Solderability	IEC 60068-2-20 test Ta	Temperature, SnPb Eutectic Temperature, Pb-free	235°C 245°C