

**PNA series PoL Regulators**  
 Input 9-36 V, Output up to 6 A / 33 W

1/28701 - BMR661 Rev. A April 2021

© Flex

### Key Features

- Small size  
 13.0 x 12.35 x 6.2 mm (0.512 x 0.486 x 0.244 in)
- 0.9 V – 5.5V output voltage range
- 6 A maximum output current
- High efficiency, typ. 93.8% at 24 Vin, 5.5 Vout, 6A load
- Control loop with fast load transient response
- Allows synchronization to an external clock
- Meets safety requirements according to IEC/EN/UL 62368-1
- MTBF 71.84 Mh

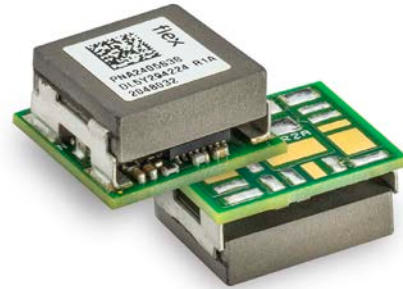

### General Characteristics

- Output voltage adjust function
- Output over current protection
- Over temperature protection
- Remote control
- Power Good
- Soft start and Output voltage tracking
- Highly automated manufacturing ensures quality
- ISO 9001/14001 certified supplier

### Safety Approvals



### Design for Environment



Meets requirements in high-temperature lead-free soldering processes.

### Contents

Ordering Information	2
General Information	2
Safety Specification	3
Absolute Maximum Ratings	4
Electrical Specification	
0.9 V/ 6 A	5
1.8 V/ 6 A	8
3.3 V/ 6 A	11
5.5 V/ 6 A	14
Operating Information	18
Thermal Consideration	20
Connections	21
Mechanical Information	22
Delivery Package Information	24
Product Qualification Specification	25

**PNA series PoL Regulators**  
Input 9-36 V, Output up to 6 A / 33 W

1/28701 - BMR661 Rev. A

April 2021

© Flex

### Ordering Information

Product number	Output
PNA2405S3S	0.9-5.5V, 6 A/ 33 W

### Product number and Packaging

PNA2405S3n <sub>1</sub> n <sub>2</sub>		
Options	n <sub>1</sub>	n <sub>2</sub>
mechanical	o	
Delivery package information		o

Options	Description	
n <sub>1</sub>	S	Surface mount (solder bump)
n <sub>2</sub>	C	Tape and reel (One full reel contains 400 pcs products.)

Example: PNA2405S3S C means a Solder bump, positive logic product with tape and reel packaging. The reel capacity is 400 pcs products per reel.

### General Information

#### Reliability

The failure rate ( $\lambda$ ) and mean time between failures (MTBF =  $1/\lambda$ ) is calculated at max output power and an operating ambient temperature ( $T_A$ ) of +40°C. Flex Power uses Telcordia SR-332 Issue 4 Method 1 to calculate the mean steady-state failure rate and standard deviation ( $\sigma$ ).

Telcordia SR-332 Issue 4 also provides techniques to estimate the upper confidence levels of failure rates based on the mean and standard deviation.

Mean steady-state failure rate, $\lambda$	Std. deviation, $\sigma$
14 nFailures/h	3.6 nFailures/h

MTBF (mean value) for the PMU series = 71.84 Mh.  
MTBF at 90% confidence level = 53.99 Mh

#### Compatibility with RoHS requirements

The products are compatible with the relevant clauses and requirements of the RoHS directive 2011/65/EU and 2015/863 and have a maximum concentration value of 0.1% by weight in homogeneous materials for lead, mercury, hexavalent chromium, PBB, PBDE, DEHP, BBP, DBP, DIBP and of 0.01% by weight in homogeneous materials for cadmium.

Exemptions in the RoHS directive utilized in Flex Power products are found in the Statement of Compliance document.

Flex Power fulfills and will continuously fulfill all its obligations under regulation (EC) No 1907/2006 concerning

the registration, evaluation, authorization and restriction of chemicals (REACH) as they enter into force and is through product materials declarations preparing for the obligations to communicate information on substances in the products.

#### Quality Statement

The products are designed and manufactured in an industrial environment where quality systems and methods like ISO 9000, Six Sigma, and SPC are intensively in use to boost the continuous improvements strategy. Infant mortality or early failures in the products are screened out and they are subjected to an ATE-based final test. Conservative design rules, design reviews and product qualifications, plus the high competence of an engaged work force, contribute to the high quality of the products.

#### Warranty

Warranty period and conditions are defined in Flex Power General Terms and Conditions of Sale.

#### Limitation of Liability

Flex Power does not make any other warranties, expressed or implied including any warranty of merchantability or fitness for a particular purpose (including, but not limited to, use in life support applications, where malfunctions of product can cause injury to a person's health or life).

#### © Flex Power 2021

The information and specifications in this technical specification is believed to be correct at the time of publication. However, no liability is accepted for inaccuracies, printing errors or for any consequences thereof. Flex Power reserves the right to change the contents of this technical specification at any time without prior notice.

<b>PNA series PoL Regulators</b> Input 9-36 V, Output up to 6 A / 33 W	1/28701 - BMR661 Rev. A	April 2021
	© Flex	

## Safety Specification

### General information

Flex DC/DC converters and DC/DC regulators are designed in accordance with the safety standards IEC 62368-1, EN 62368-1 and UL 62368-1 *Audio/video, information and communication technology equipment - Part 1: Safety requirements*

IEC/EN/UL 62368-1 contains requirements to prevent injury or damage due to the following hazards:

- Electrical shock
- Electrically-caused fire
- Injury caused by hazardous substances
- Mechanically-caused injury
- Skin burn
- Radiation-caused injury

On-board DC/DC converters, Power interface modules and DC/DC regulators are defined as component power supplies. As components they cannot fully comply with the provisions of any safety requirements without “conditions of acceptability”. Clearance between conductors and between conductive parts of the component power supply and conductors on the board in the final product must meet the applicable safety requirements. Certain conditions of acceptability apply for component power supplies with limited stand-off (see Mechanical Information for further information). It is the responsibility of the installer to ensure that the final product housing these components complies with the requirements of all applicable safety standards and regulations for the final product.

Component power supplies for general use shall comply with the requirements in IEC/EN/UL 62368-1. Product related standards, e.g. IEEE 802.3af *Power over Ethernet*, and ETS-300132-2 *Power interface at the input to telecom equipment, operated by direct current (dc)* are based on IEC/EN/UL 60950-1 with regards to safety.

Flex DC/DC converters, Power interface modules and DC/DC regulators are UL 62368-1 recognized and certified in accordance with EN 62368-1. The flammability rating for all construction parts of the products meet requirements for V-0 class material according to IEC 60695-11-10, *Fire hazard testing, test flames – 50 W horizontal and vertical flame test methods*.

### Non - isolated DC/DC regulators

The DC/DC regulator output is ES1 energy source if the input source meets the requirements for ES1 according to IEC/EN/UL 62368-1.

**PNA series PoL Regulators**  
 Input 9-36 V, Output up to 6 A / 33 W

1/28701 - BMR661 Rev. A April 2021  
 © Flex

**Absolute Maximum Ratings**

Characteristics		min	typ	max	Unit
T <sub>P1</sub>	Operating Temperature (See Thermal Consideration section)	-40		+125	°C
T <sub>S</sub>	Storage temperature	-55		+150	°C
V <sub>I</sub>	Input voltage	9		36	V
V <sub>RC</sub>	Remote Control pin voltage (see Operating Information section)	Positive logic		36	V

Stresses above those listed under Absolute Maximum Ratings may cause permanent damage to the device. This is a stress rating only; functional operation of the device at these or any other conditions above those indicated in the Electrical Specification section of this specification is not implied. Exposure to absolute maximum rating conditions for extended periods may affect device reliability.

**Typical Application Diagram**

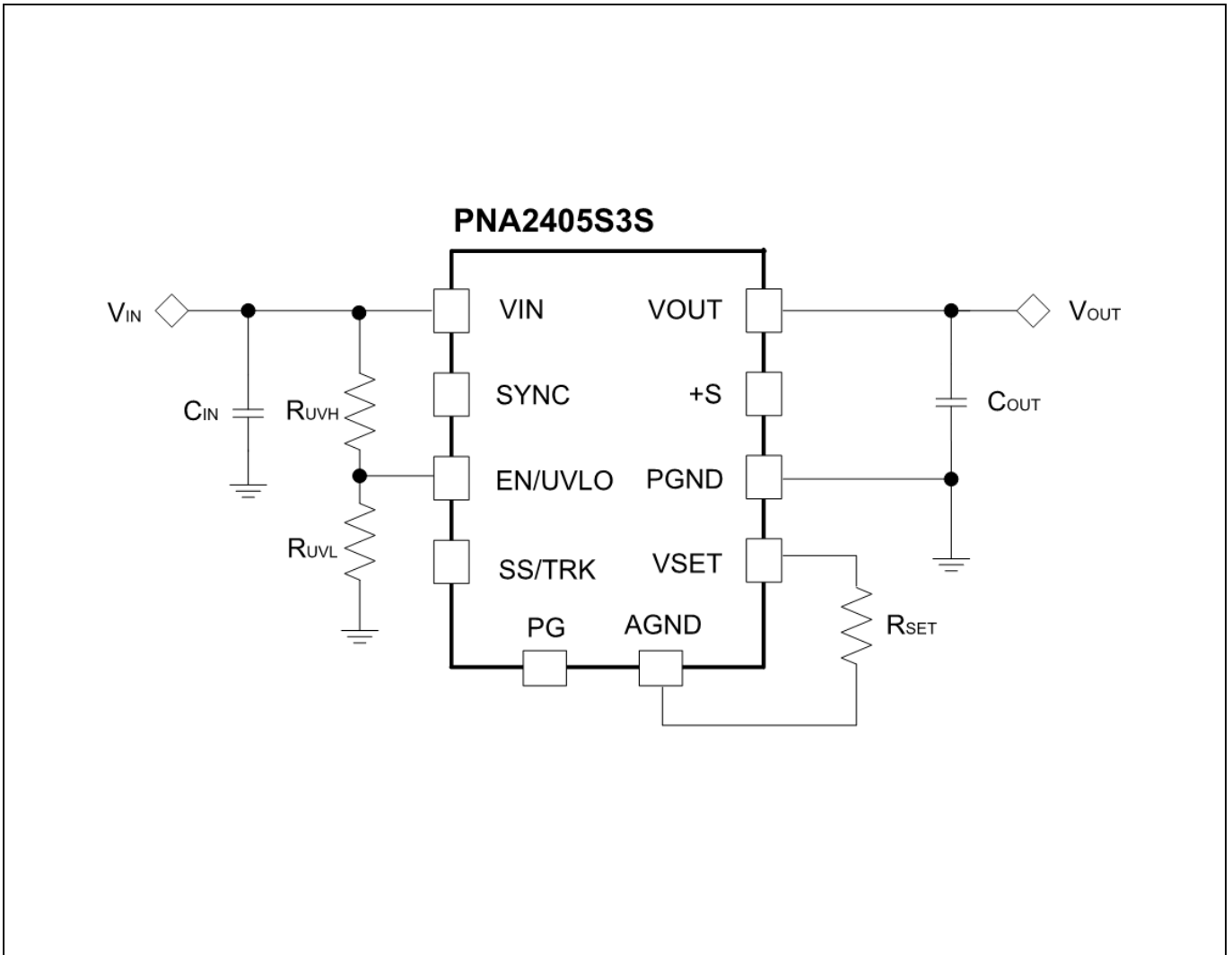

**PNA series PoL Regulators**  
 Input 9-36 V, Output up to 6 A / 33 W

1/28701 - BMR661 Rev. A

April 2021

© Flex

**Electrical Specification**  
**0.9 V, 6 A / 5.4 W**
**PNA2405S3S**
 $T_{P1} = -40$  to  $+85$  °C,  $V_I = 9$  to  $28$  V, unless otherwise specified under Conditions.

 Typical values given at:  $T_{P1} = +25$  °C,  $V_I = 24$  V, max  $I_O$ , unless otherwise specified under Conditions.

 Additional  $C_{in} = 100$   $\mu$ F Electrolytic<sup>1</sup> + 2 x 4.7  $\mu$ F Ceramic,  $C_{out} = 2$  x 47  $\mu$ F Ceramic.

Characteristics		Conditions	min	typ	max	Unit
$V_I$	Input voltage range		9 <sup>2</sup>		28	V
$V_{loff}$	Turn-off input voltage	Decreasing input voltage		7		V
$V_{lon}$	Turn-on input voltage	Increasing input voltage		8		V
$C_I$	Internal input capacitance			1.1		$\mu$ F
$P_O$	Output power		0		5.4	W
$\eta$	Efficiency	50% of max $I_O$		72.5		%
		max $I_O$		75.9		
		50% of max $I_O$ , $V_I = 12$ V		83.2		
		max $I_O$ , $V_I = 12$ V		83.0		
$P_d$	Power Dissipation	max $I_O$		1.7		W
$P_{li}$	Input idling power	$I_O = 0$ A, $V_I = 24$ V		0.1		W
$P_{RC}$	Input standby power	$V_I = 24$ V (turned off with RC)		50		mW
$f_s$	Switching frequency	0-100 % of max $I_O$		450		kHz
$V_{Oi}$	Output voltage initial setting and accuracy	$T_{P1} = +25$ °C, $V_I = 24$ V, $I_O = 6$ A		0.9		V
$V_O$	Idling voltage	$I_O = 0$ A		0.9		V
	Line regulation	max $I_O$			9	mV
	Load regulation	$V_I = 24$ V, 0-100 % of max $I_O$			9	mV
$V_{tr}$	Load transient voltage deviation	$V_I = 24$ V, Load step 25-75-25% of max $I_O$ , $di/dt = 1$ A/ $\mu$ s		$\pm 50$		mV
$t_{tr}$	Load transient recovery time				80	$\mu$ s
$t_r$	Ramp-up time (from 10-90% of $V_{Oi}$ )	$V_I = 24$ V, $I_O = \text{max } I_O$		3		ms
$t_s$	Start-up time (from $V_I$ connection to 90% of $V_{Oi}$ )			4		ms
$t_f$	Shut-down time (from $V_I$ off to 10% of $V_{Oi}$ )	$V_I = 24$ V, $I_O = \text{max } I_O$		30		ms
$t_{RC}$	RC start-up time (from $V_{RC}$ connection to 90% of $V_{Oi}$ )	max $I_O$		4		ms
RC	Trigger level	Increasing RC-voltage		1.2		V
$I_O$	Output current		0		6	A
$I_{lim}$	Current limit threshold	$T_{P1} < \text{max } T_{P1}$	8	8.5	10	A
$I_{sc}$	Short circuit current	$T_{P1} = 25$ °C, RMS		1.7		A
$V_{Oac}$	Output ripple & noise	See ripple & noise section, $V_{Oi}$		6.1	9	mVp-p

 Note 1. Electrolytic capacitor UPS2A101MHD from Nichicon with typical ESR value 0.18  $\Omega$  (20 °C 100 kHz).

Note 2. Minimum input voltage is increased for high output voltages. For output voltages below 5.0V, input undervoltage lockout threshold is recommended to set to 7V. For output voltages above 5.0V, input undervoltage lockout threshold is recommended to set to 9V. See Remote control and input undervoltage lockout (EN/UVLO) section for detailed information.

**PNA series PoL Regulators**  
 Input 9-36 V, Output up to 6 A / 33 W

1/28701 - BMR661 Rev. A April 2021  
 © Flex

**Typical Characteristics**  
**0.9 V, 6 A / 5.4 W**

**PNA2405S3S**

**Efficiency**

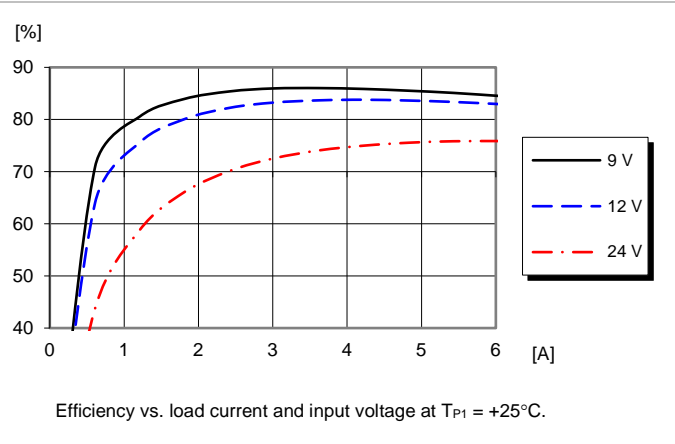

**Power Dissipation**

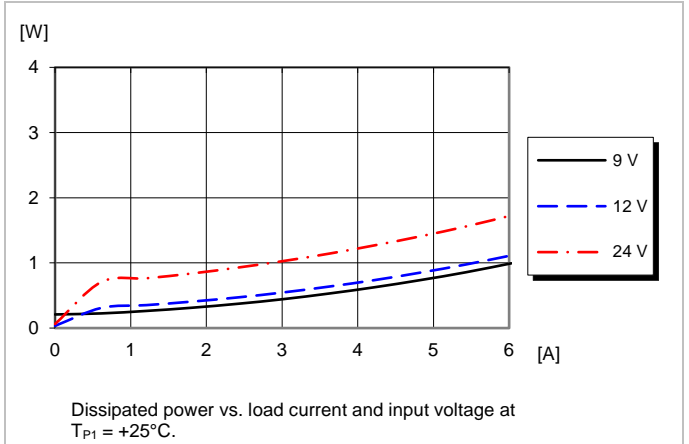

**Thermal Derating**

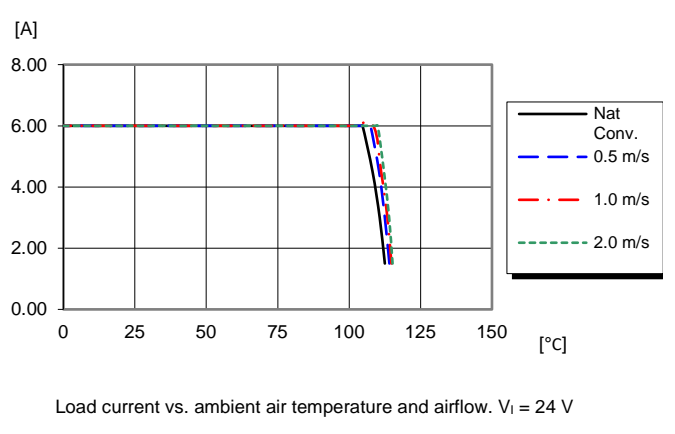

**Load Regulation**

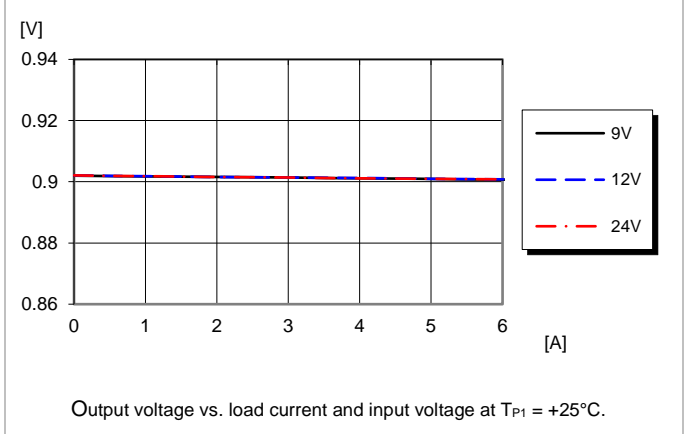

**PNA series PoL Regulators**  
 Input 9-36 V, Output up to 6 A / 33 W

1/28701 - BMR661 Rev. A April 2021  
 © Flex

### Typical Characteristics

**0.9 V, 6 A / 5.4 W**

**PNA2405S3S**

#### Start-up

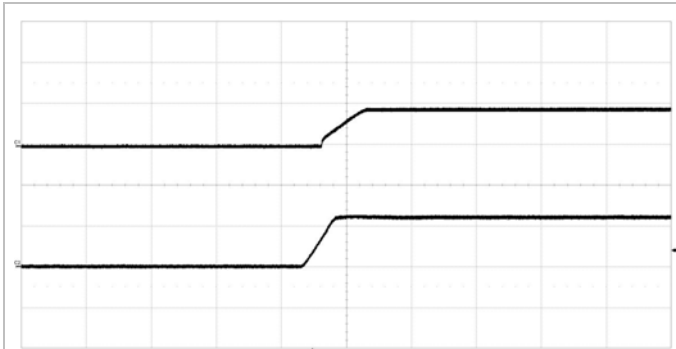

Start-up enabled by connecting  $V_I$  at:  
 $T_{P1} = +25^\circ\text{C}$ ,  $V_I = 24\text{ V}$ ,  
 $I_O = 6\text{ A}$  resistive load.

Top trace: output voltage 1 V/div.  
 Bottom trace: input voltage 20 V/div.  
 Time scale: 5 ms/div.

#### Shut-down

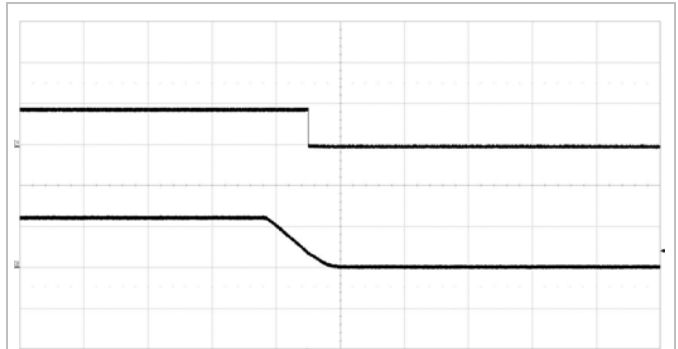

Shut-down enabled by disconnecting  $V_I$  at:  
 $T_{P1} = +25^\circ\text{C}$ ,  $V_I = 24\text{ V}$ ,  
 $I_O = 6\text{ A}$  resistive load.

Top trace: output voltage 1 V/div.  
 Bottom trace: input voltage 20 V/div.  
 Time scale: 50 ms/div.

#### Output Ripple & Noise

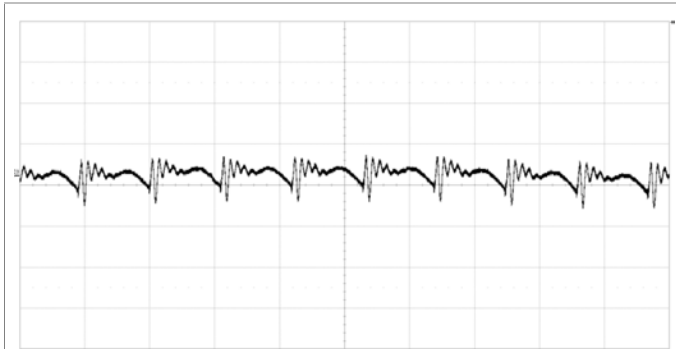

Output voltage ripple at:  
 $T_{P1} = +25^\circ\text{C}$ ,  $V_I = 24\text{ V}$ ,  
 $I_O = 6\text{ A}$  electronic load.

Trace: output voltage 5 mV/div.  
 Time scale: 2  $\mu\text{s}$ /div.  
 20 MHz bandwidth.

#### Output Load Transient Response



Output voltage response to load current step-  
 change 1.5-4.5-1.5 A at:  
 $T_{P1} = +25^\circ\text{C}$ ,  $V_I = 24\text{ V}$ .  
 $C_{OUT} = 2 \times 47\text{ }\mu\text{F Ceramic} + 330\text{ }\mu\text{F Polymer}$

Top trace: output voltage 50 mV/div.  
 Bottom trace: load current 2 A/div.  
 Time scale: 200  $\mu\text{s}$ /div.  
 Slew rate: 1A/ $\mu\text{s}$ .  
 20 MHz bandwidth.

**PNA series PoL Regulators**  
 Input 9-36 V, Output up to 6 A / 33 W

1/28701 - BMR661 Rev. A

April 2021

© Flex

**Electrical Specification**  
**1.8 V, 6 A / 10.8 W**
**PNA2405S3S**
 $T_{P1} = -40$  to  $+85$  °C,  $V_I = 9$  to  $36$  V, unless otherwise specified under Conditions.

 Typical values given at:  $T_{P1} = +25$  °C,  $V_I = 24$  V, max  $I_O$ , unless otherwise specified under Conditions.

 Additional  $C_{in} = 100$  µF Electrolytic<sup>1</sup> + 2 x 4.7 µF Ceramic,  $C_{out} = 2$  x 47 µF Ceramic.

Characteristics		Conditions	min	typ	max	Unit
$V_I$	Input voltage range		9 <sup>2</sup>		36	V
$V_{loff}$	Turn-off input voltage	Decreasing input voltage		7		V
$V_{lon}$	Turn-on input voltage	Increasing input voltage		8		V
$C_I$	Internal input capacitance			1.1		µF
$P_O$	Output power		0		10.8	W
$\eta$	Efficiency	50% of max $I_O$		83.6		%
		max $I_O$		85.8		
		50% of max $I_O$ , $V_I = 12$ V		90.3		
		max $I_O$ , $V_I = 12$ V		90.0		
$P_d$	Power Dissipation	max $I_O$		1.8		W
$P_{li}$	Input idling power	$I_O = 0$ A, $V_I = 24$ V		0.2		W
$P_{RC}$	Input standby power	$V_I = 24$ V (turned off with RC)		50		mW
$f_s$	Switching frequency	0-100 % of max $I_O$		450		kHz
$V_{oi}$	Output voltage initial setting and accuracy	$T_{P1} = +25$ °C, $V_I = 24$ V, $I_O = 6$ A		1.78		V
$V_O$	Idling voltage	$I_O = 0$ A		1.78		V
	Line regulation	max $I_O$			18	mV
	Load regulation	$V_I = 24$ V, 0-100 % of max $I_O$			18	mV
$V_{tr}$	Load transient voltage deviation	$V_I = 24$ V, Load step 25-75-25% of max $I_O$ , $di/dt = 1$ A/µs		±60		mV
$t_{tr}$	Load transient recovery time				80	µs
$t_r$	Ramp-up time (from 10-90% of $V_{oi}$ )	$V_I = 24$ V, $I_O = \text{max } I_O$		3		ms
$t_s$	Start-up time (from $V_I$ connection to 90% of $V_{oi}$ )			4.5		ms
$t_f$	Shut-down time (from $V_I$ off to 10% of $V_{oi}$ )	$V_I = 24$ V, $I_O = \text{max } I_O$		25		ms
$t_{RC}$	RC start-up time (from $V_{RC}$ connection to 90% of $V_{oi}$ )	max $I_O$		4		ms
RC	Trigger level	Increasing RC-voltage		1.2		V
$I_O$	Output current		0		6	A
$I_{lim}$	Current limit threshold	$T_{P1} < \text{max } T_{P1}$	8	8.5	10	A
$I_{sc}$	Short circuit current	$T_{P1} = 25$ °C, RMS		1.7		A
$V_{Oac}$	Output ripple & noise	See ripple & noise section, $V_{oi}$		7	18	mVp-p

Note 1. Electrolytic capacitor UPS2A101MHD from Nichicon with typical ESR value 0.18 Ω (20 °C 100 kHz).

Note 2. Minimum input voltage is increased for high output voltages. For output voltages below 5.0V, input undervoltage lockout threshold is recommended to set to 7V. For output voltages above 5.0V, input undervoltage lockout threshold is recommended to set to 9V. See Remote control and input undervoltage lockout (EN/UVLO) section for detailed information.



**PNA series PoL Regulators**  
 Input 9-36 V, Output up to 6 A / 33 W

1/28701 - BMR661 Rev. A April 2021  
 © Flex

**Typical Characteristics**  
**1.8 V, 6 A /10.8 W**

**PNA2405S3S**

**Efficiency**

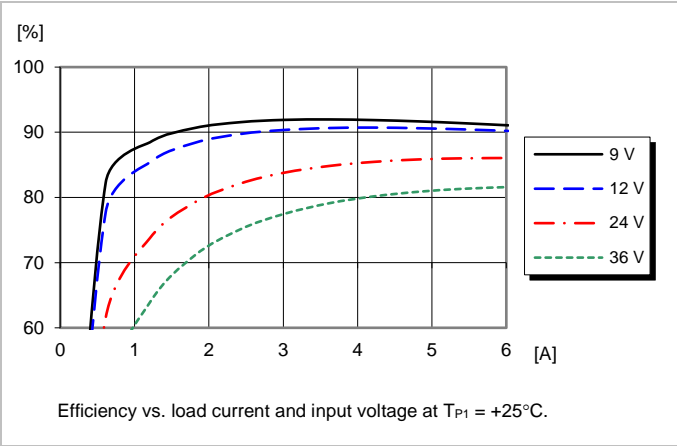

**Power Dissipation**

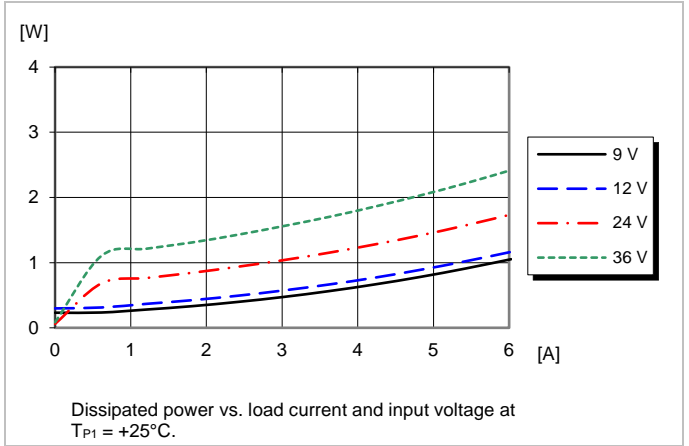

**Thermal Derating**

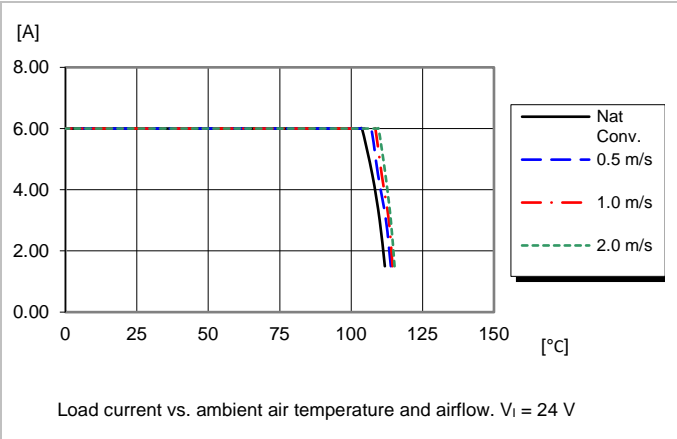

**Load Regulation**

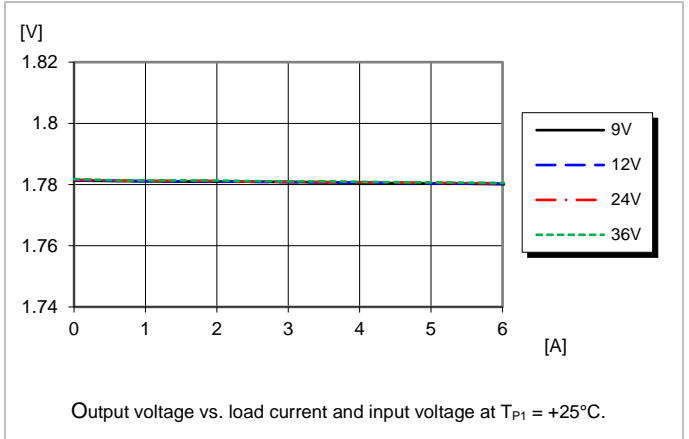

**PNA series PoL Regulators**  
 Input 9-36 V, Output up to 6 A / 33 W

1/28701 - BMR661 Rev. A April 2021  
 © Flex

**Typical Characteristics**  
**1.8 V, 6 A / 10.8 W**

**PNA2405S3S**

**Start-up**

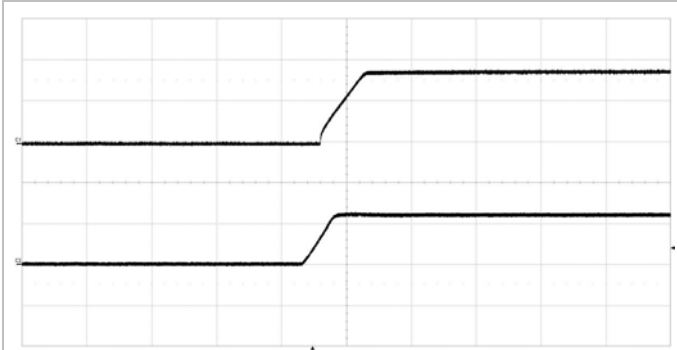

Start-up enabled by connecting  $V_I$  at:  
 $T_{P1} = +25^{\circ}\text{C}$ ,  $V_I = 24\text{ V}$ ,  
 $I_O = 6\text{ A}$  resistive load.  
 Top trace: output voltage 1 V/div.  
 Bottom trace: input voltage 20 V/div.  
 Time scale: 5 ms/div.

**Shut-down**

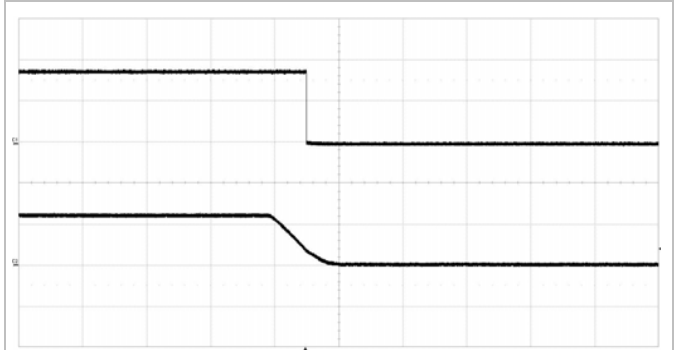

Shut-down enabled by disconnecting  $V_I$  at:  
 $T_{P1} = +25^{\circ}\text{C}$ ,  $V_I = 24\text{ V}$ ,  
 $I_O = 6\text{ A}$  resistive load.  
 Top trace: output voltage 1 V/div.  
 Bottom trace: input voltage 20 V/div.  
 Time scale: 50 ms/div.

**Output Ripple & Noise**

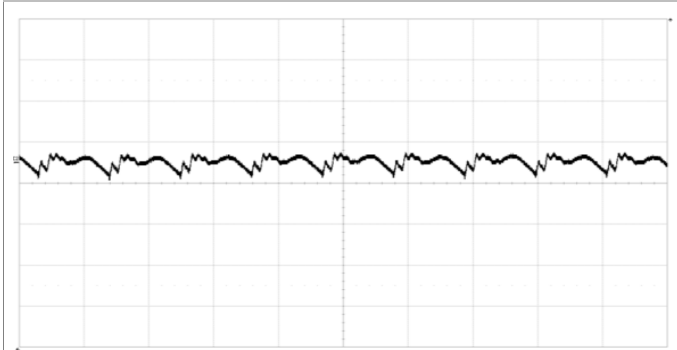

Output voltage ripple at:  
 $T_{P1} = +25^{\circ}\text{C}$ ,  $V_I = 24\text{ V}$ ,  
 $I_O = 6\text{ A}$  electronic load.  
 Trace: output voltage 10 mV/div.  
 Time scale: 2  $\mu\text{s}$ /div.  
 20 MHz bandwidth.

**Output Load Transient Response**

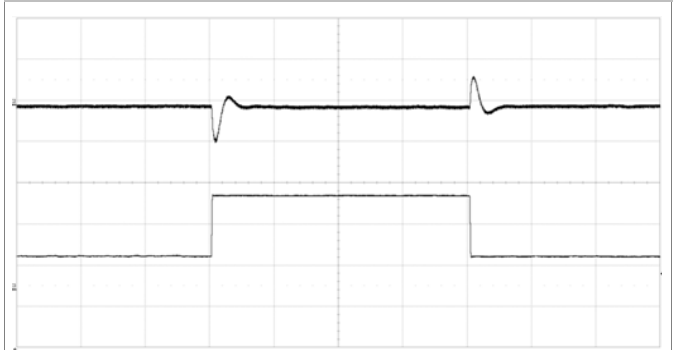

Output voltage response to load current step-  
 change 1.5-4.5-1.5 A at:  
 $T_{P1} = +25^{\circ}\text{C}$ ,  $V_I = 24\text{ V}$ .  
 $C_{OUT} = 2 \times 47\text{ }\mu\text{F Ceramic} + 330\text{ }\mu\text{F Polymer}$   
 Top trace: output voltage 50 mV/div.  
 Bottom trace: load current 2 A/div.  
 Time scale: 200  $\mu\text{s}$ /div.  
 Slew rate: 1A/ $\mu\text{s}$ .  
 20 MHz bandwidth.

**PNA series PoL Regulators**  
 Input 9-36 V, Output up to 6 A / 33 W

1/28701 - BMR661 Rev. A

April 2021

© Flex

**Electrical Specification**  
**3.3 V, 6 A /19.8 W**
**PNA2405S3S**
 $T_{P1} = -40$  to  $+85$  °C,  $V_I = 9$  to  $36$  V, unless otherwise specified under Conditions.

 Typical values given at:  $T_{P1} = +25$  °C,  $V_I = 24$  V, max  $I_O$ , unless otherwise specified under Conditions.

 Additional  $C_{in} = 100$   $\mu$ F Electrolytic<sup>1</sup> + 2 x 4.7  $\mu$ F Ceramic,  $C_{out} = 2$  x 47  $\mu$ F Ceramic.

Characteristics		Conditions	min	typ	max	Unit
$V_I$	Input voltage range		9 <sup>2</sup>		36	V
$V_{loff}$	Turn-off input voltage	Decreasing input voltage		7		V
$V_{lon}$	Turn-on input voltage	Increasing input voltage		8		V
$C_I$	Internal input capacitance			1.1		$\mu$ F
$P_O$	Output power		0		19.8	W
$\eta$	Efficiency	50% of max $I_O$		89.6		%
		max $I_O$		91.2		
		50% of max $I_O$ , $V_I = 12$ V		93.7		
		max $I_O$ , $V_I = 12$ V		93.4		
$P_d$	Power Dissipation	max $I_O$		1.9		W
$P_{li}$	Input idling power	$I_O = 0$ A, $V_I = 24$ V		0.7		W
$P_{RC}$	Input standby power	$V_I = 24$ V (turned off with RC)		50		mW
$f_s$	Switching frequency	0-100 % of max $I_O$		450		kHz
$V_{Oi}$	Output voltage initial setting and accuracy	$T_{P1} = +25$ °C, $V_I = 24$ V, $I_O = 6$ A		3.27		V
$V_O$	Idling voltage	$I_O = 0$ A		3.27		V
	Line regulation	max $I_O$			33	mV
	Load regulation	$V_I = 24$ V, 0-100 % of max $I_O$			33	mV
$V_{tr}$	Load transient voltage deviation	$V_I = 24$ V, Load step 25-75-25% of max $I_O$ , $di/dt = 1$ A/ $\mu$ s		$\pm 60$		mV
$t_{tr}$	Load transient recovery time				100	$\mu$ s
$t_r$	Ramp-up time (from 10-90% of $V_{Oi}$ )	$V_I = 24$ V, $I_O = \text{max } I_O$		3		ms
$t_s$	Start-up time (from $V_I$ connection to 90% of $V_{Oi}$ )			4		ms
$t_f$	Shut-down time (from $V_I$ off to 10% of $V_{Oi}$ )	$V_I = 24$ V, $I_O = \text{max } I_O$		20		ms
$t_{RC}$	RC start-up time (from $V_{RC}$ connection to 90% of $V_{Oi}$ )	max $I_O$		4		ms
RC	Trigger level	Increasing RC-voltage		1.2		V
$I_O$	Output current		0		6	A
$I_{lim}$	Current limit threshold	$T_{P1} < \text{max } T_{P1}$	8	8.5	11	A
$I_{sc}$	Short circuit current	$T_{P1} = 25$ °C, RMS		1.7		A
$V_{Oac}$	Output ripple & noise	See ripple & noise section, $V_{Oi}$		10	33	mVp-p

 Note 1. Electrolytic capacitor UPS2A101MHD from Nichicon with typical ESR value 0.18  $\Omega$  (20 °C 100 kHz).

Note 2. Minimum input voltage is increased for high output voltages. For output voltages below 5.0V, input undervoltage lockout threshold is recommended to set to 7V. For output voltages above 5.0V, input undervoltage lockout threshold is recommended to set to 9V. See Remote control and input undervoltage lockout (EN/UVLO) section for detailed information.

**PNA series PoL Regulators**  
 Input 9-36 V, Output up to 6 A / 33 W

1/28701 - BMR661 Rev. A April 2021  
 © Flex

**Typical Characteristics**  
**3.3 V, 6 A / 19.8 W**

**PNA2405S3S**

**Efficiency**

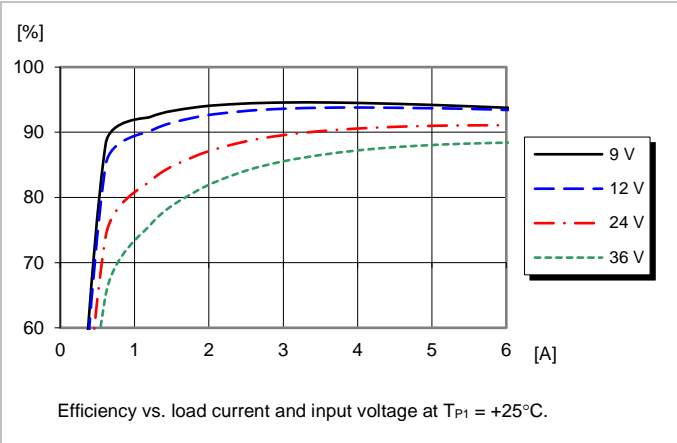

**Power Dissipation**

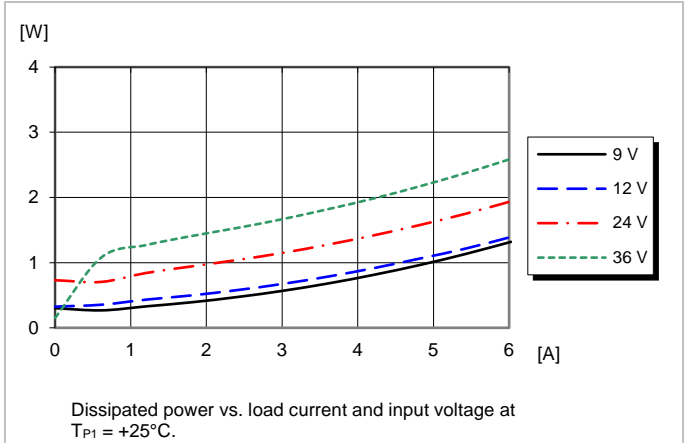

**Thermal Derating**

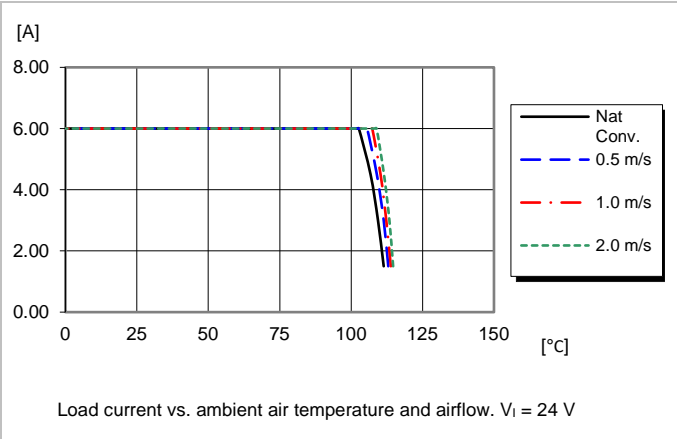

**Load Regulation**

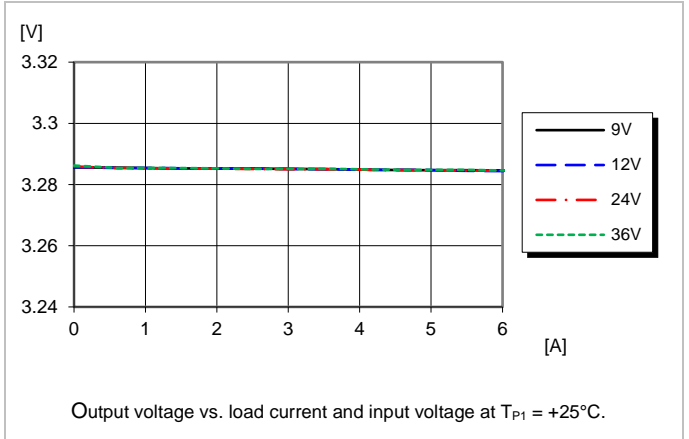

**PNA series PoL Regulators**  
 Input 9-36 V, Output up to 6 A / 33 W

1/28701 - BMR661 Rev. A April 2021  
 © Flex

**Typical Characteristics**  
**3.3 V, 6 A / 19.8 W**

**PNA2405S3S**

**Start-up**

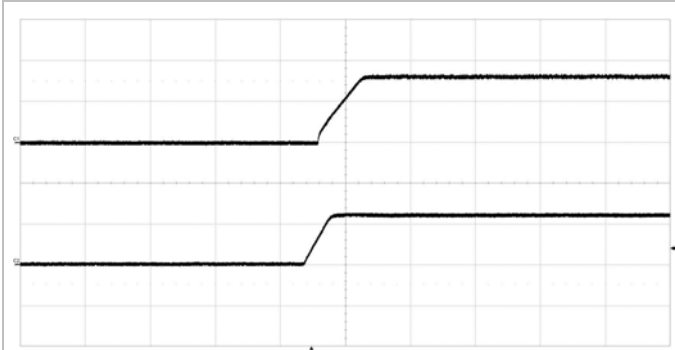

Start-up enabled by connecting  $V_I$  at:  
 $T_{P1} = +25^{\circ}\text{C}$ ,  $V_I = 24\text{ V}$ ,  
 $I_O = 6\text{ A}$  resistive load.  
 Top trace: output voltage 2 V/div.  
 Bottom trace: input voltage 20 V/div.  
 Time scale: 50 ms/div.

**Shut-down**

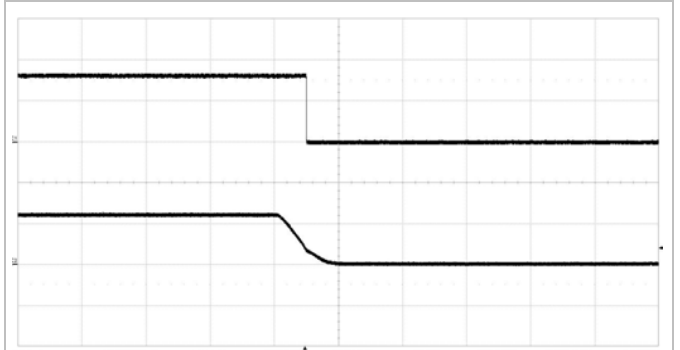

Shut-down enabled by disconnecting  $V_I$  at:  
 $T_{P1} = +25^{\circ}\text{C}$ ,  $V_I = 24\text{ V}$ ,  
 $I_O = 6\text{ A}$  resistive load.  
 Top trace: output voltage 2 V/div.  
 Bottom trace: input voltage 20 V/div.  
 Time scale: 50 ms/div.

**Output Ripple & Noise**

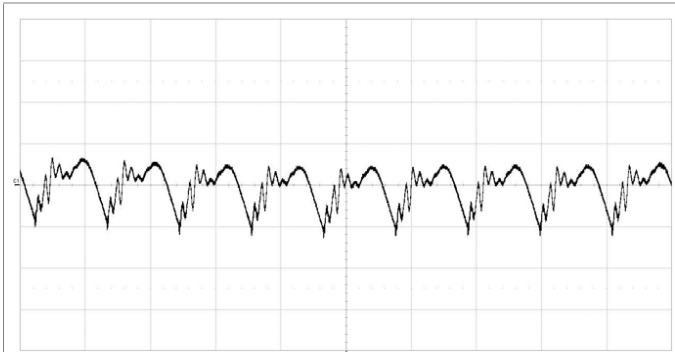

Output voltage ripple at:  
 $T_{P1} = +25^{\circ}\text{C}$ ,  $V_I = 24\text{ V}$ ,  
 $I_O = 6\text{ A}$  electronic load.  
 Trace: output voltage 5 mV/div.  
 Time scale: 2  $\mu\text{s}$ /div.  
 20 MHz bandwidth.

**Output Load Transient Response**



Output voltage response to load current step-change 1.5-4.5-1.5 A at:  
 $T_{P1} = +25^{\circ}\text{C}$ ,  $V_I = 24\text{ V}$ .  
 $C_{OUT} = 2 \times 47\text{ }\mu\text{F Ceramic} + 330\text{ }\mu\text{F Polymer}$   
 Top trace: output voltage 100 mV/div.  
 Bottom trace: load current 2 A/div.  
 Time scale: 100  $\mu\text{s}$ /div.  
 Slew rate: 1A/ $\mu\text{s}$ .  
 20 MHz bandwidth.

**PNA series PoL Regulators**  
 Input 9-36 V, Output up to 6 A / 33 W

1/28701 - BMR661 Rev. A

April 2021

© Flex

**Electrical Specification**  
**5.5 V, 6 A / 33 W**
**PNA2405S3S**
 $T_{P1} = -40$  to  $+85$  °C,  $V_I = 12$  to 36 V, unless otherwise specified under Conditions.

 Typical values given at:  $T_{P1} = +25$  °C,  $V_I = 24$  V, max  $I_O$ , unless otherwise specified under Conditions.

 Additional  $C_{in} = 100$   $\mu$ F Electrolytic<sup>1</sup>+ 2 x 4.7  $\mu$ F Ceramic,  $C_{out} = 2$  x 47  $\mu$ F Ceramic.

Characteristics		Conditions	min	typ	max	Unit
$V_I$	Input voltage range		11 <sup>2</sup>		36	V
$V_{loff}$	Turn-off input voltage	Decreasing input voltage		7		V
$V_{lon}$	Turn-on input voltage	Increasing input voltage		8		V
$C_I$	Internal input capacitance			1.1		$\mu$ F
$P_O$	Output power		0		33	W
$\eta$	Efficiency	50% of max $I_O$		92.4		%
		max $I_O$		93.8		
		50% of max $I_O$ , $V_I = 12$ V		95.7		
		max $I_O$ , $V_I = 12$ V		95.5		
$P_d$	Power Dissipation	max $I_O$		2.2		W
$P_{li}$	Input idling power	$I_O = 0$ A, $V_I = 24$ V		0.8		W
$P_{RC}$	Input standby power	$V_I = 24$ V (turned off with RC)		40		mW
$f_s$	Switching frequency	0-100 % of max $I_O$		450		kHz
$V_{oi}$	Output voltage initial setting and accuracy	$T_{P1} = +25$ °C, $V_I = 24$ V, $I_O = 6$ A		5.49		V
$V_O$	Idling voltage	$I_O = 0$ A		5.49		V
	Line regulation	max $I_O$			55	mV
	Load regulation	$V_I = 24$ V, 0-100 % of max $I_O$		2	55	mV
$V_{tr}$	Load transient voltage deviation	$V_I = 24$ V, Load step 25-75-25% of max $I_O$ , $di/dt = 1$ A/ $\mu$ s		$\pm 50$		mV
$t_{tr}$	Load transient recovery time				100	$\mu$ s
$t_r$	Ramp-up time (from 10-90% of $V_{oi}$ )	$V_I = 24$ V, $I_O = \text{max } I_O$		3		ms
$t_s$	Start-up time (from $V_I$ connection to 90% of $V_{oi}$ )			4		ms
$t_f$	Shut-down time (from $V_I$ off to 10% of $V_{oi}$ )			16		ms
$t_{RC}$	RC start-up time (from $V_{RC}$ connection to 90% of $V_{oi}$ )	max $I_O$		4		ms
RC	Trigger level	Increasing RC-voltage		1.2		V
$I_O$	Output current		0		6	A
$I_{lim}$	Current limit threshold	$T_{P1} < \text{max } T_{P1}$	8	10	11	A
$I_{sc}$	Short circuit current	$T_{P1} = 25$ °C, RMS		1.6		A
$V_{Oac}$	Output ripple & noise	See ripple & noise section, $V_{oi}$		14	55	mVp-p

 Note 1. Electrolytic capacitor UPS2A101MHD from Nichicon with typical ESR value 0.18  $\Omega$  (20 °C 100 kHz).

Note 2. Minimum input voltage is increased for high output voltages. For output voltages below 5.0V, input undervoltage lockout threshold is recommended to set to 7V. For output voltages above 5.0V, input undervoltage lockout threshold is recommended to set to 9V. See Remote control and input undervoltage lockout (EN/UVLO) section for detailed information.



**PNA series PoL Regulators**  
 Input 9-36 V, Output up to 6 A / 33 W

1/28701 - BMR661 Rev. A April 2021  
 © Flex

**Typical Characteristics**  
**5.5 V, 6 A / 33 W**

**PNA2405S3S**

**Start-up**

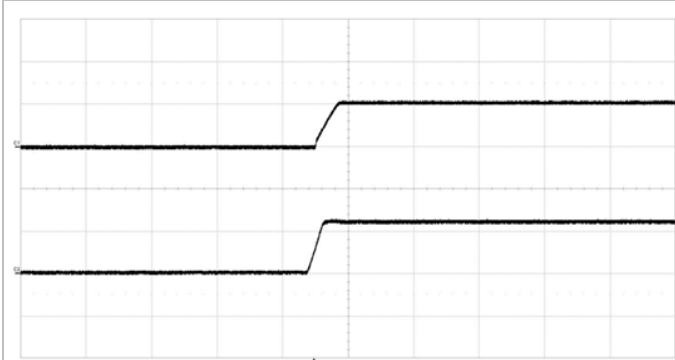

Start-up enabled by connecting  $V_I$  at:  
 $T_{P1} = +25^{\circ}\text{C}$ ,  $V_I = 24\text{ V}$ ,  
 $I_O = 6\text{ A}$  resistive load.  
 Top trace: output voltage 5 V/div.  
 Bottom trace: input voltage 20 V/div.  
 Time scale: 10 ms/div.

**Shut-down**

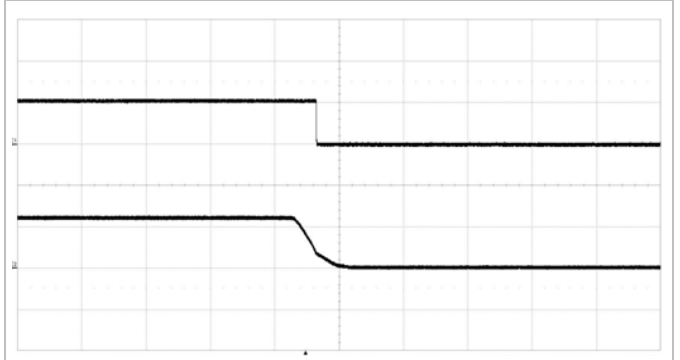

Shut-down enabled by disconnecting  $V_I$  at:  
 $T_{P1} = +25^{\circ}\text{C}$ ,  $V_I = 24\text{ V}$ ,  
 $I_O = 6\text{ A}$  resistive load.  
 Top trace: output voltage 5 V/div.  
 Bottom trace: input voltage 20 V/div.  
 Time scale: 50 ms/div.

**Output Ripple & Noise**

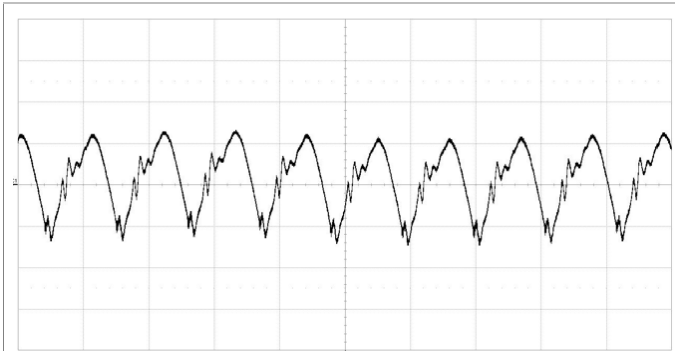

Output voltage ripple at:  
 $T_{P1} = +25^{\circ}\text{C}$ ,  $V_I = 24\text{ V}$ ,  
 $I_O = 6\text{ A}$  electronic load.  
 Trace: output voltage 5 mV/div.  
 Time scale: 2  $\mu\text{s}$ /div.  
 20 MHz bandwidth.

**Output Load Transient Response**

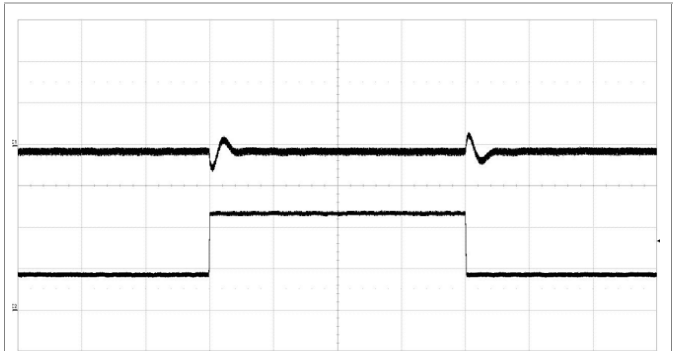

Output voltage response to load current step-  
 change 1.5-4.5-1.5 A at:  
 $T_{P1} = +25^{\circ}\text{C}$ ,  $V_I = 24\text{ V}$ .  
 $C_{OUT} = 2 \times 47\text{ }\mu\text{F Ceramic} + 330\text{ }\mu\text{F Polymer}$   
 Top trace: output voltage 100 mV/div.  
 Bottom trace: load current 2 A/div.  
 Time scale: 200  $\mu\text{s}$ /div.  
 Slew rate: 1A/ $\mu\text{s}$ .  
 20 MHz bandwidth.



**PNA series PoL Regulators**  
 Input 9-36 V, Output up to 6 A / 33 W

1/28701 - BMR661 Rev. A

April 2021

© Flex

**Output ripple and noise**

Output ripple and noise measured according to figure below.

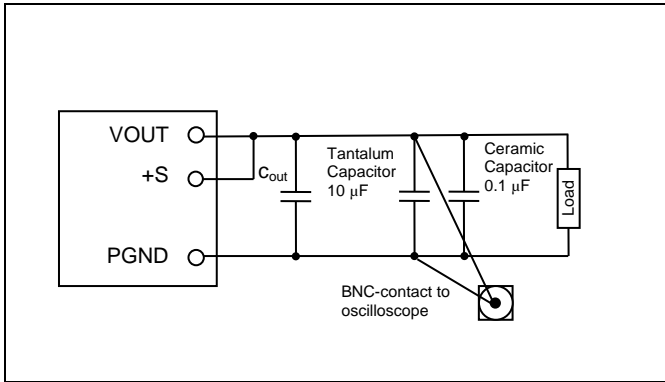

*Output ripple and noise test setup*

The module is designed for low ripple voltage at the module output and will meet the maximum output ripple specification with 0.1 µF ceramic and 10 µF tantalum at the output of the module.

The loop compensation setting is designed to provide stability, accurate line and load regulation and good transient performance for a wide range of operating conditions. Inherent from the implementation and normal to the product there will be some low frequency ripple at the output, in addition to the fundamental switching frequency output ripple. This low frequency ripple is not related to instability of control loop. The total output ripple and noise is maintained at a low level.

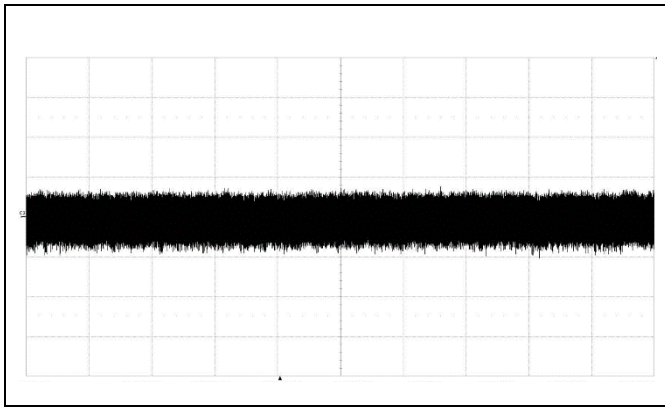

$V_I = 24\text{ V}$ ,  $V_{OUT} = 5.5\text{ V}$ ,  $I_O = 6\text{ A}$ ,  $C_{OUT} = 2 \times 47\text{ }\mu\text{F}$ , 20 mV/div, 1 ms/div

*Example of low frequency ripple at the output.*

**PNA series PoL Regulators**  
Input 9-36 V, Output up to 6 A / 33 W

1/28701 - BMR661 Rev. A April 2021

© Flex

## Operating information

### Input Voltage

The input voltage range is 9 to 36 Vdc meets typical requirements in 12 V DC and 24 V DC system used in telecom, datacom, industrial and medical equipment.

### Remote control and input undervoltage lockout (EN/UVLO)

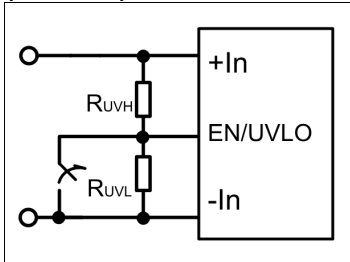

The products are fitted with a remote control function referenced to the negative input connection (-In). The remote control function allows the product to be turned on/off by an external device like a semiconductor or mechanical switch.

The standard product is provided with “positive logic”. An external pull up resistor is required for EN pin. To turn on the product, EN pin should be left open. To turn off the product, EN pin should be connected to -In.

The device also supports adjustable input undervoltage lockout setting by adding a voltage divider on EN/UVLO pin. When EN voltage is below 0.37V, the device is in shutdown mode. When it exceeds 1.2V, an internal 10  $\mu$ A current source is enabled and flows through the external voltage divider to provide hysteresis. The high side and low side resistor values could be calculated by Equation 1 and 2.

$$R_{UVH} = \frac{V_{IN(ON)} - V_{IN(OFF)}}{10\mu A} \quad \text{Equation 1}$$

$$R_{UVL} = R_{UVH} * \frac{1.2}{V_{IN(ON)} - 1.2} \quad \text{Equation 2}$$

### Input and Output Impedance

The impedance of both the input source and the load will interact with the impedance of the product. It is important that the input source has low characteristic impedance. If the input voltage source contains significant inductance, the addition of a capacitor with low ESR across the input of the product will ensure stable operation.

### External Input Capacitors

It is recommended to use a combination of ceramic capacitors and an electrolytic capacitor on the input side. Additional 100  $\mu$ F of non-ceramic capacitance is recommended for applications with large transient load requirements. At least 50 V voltage rating is recommended for both type of capacitors to cover the wide input voltage range.

The required ceramic capacitors must be placed as close as possible to VIN pins to minimize the input voltage ripple.

### External Output Capacitors

The output capacitors must have low ESR value to achieve low output ripple voltage.

External output capacitors must be placed as close as possible to VOUT pins of the product. Minimum two 47  $\mu$ F ceramic capacitors are recommended. It is important to use low resistance and low inductance PCB layout and cabling for effective capacitance.

### Remote Sense (+S)

The products have remote sense that can be used to compensate for voltage drops between the output and the point of load. The sense traces should be located close to the PWB ground layer to reduce noise susceptibility.

The internal resistor between +S and VOUT is 47 $\Omega$ . If the remote sense is not needed, +S should be connected to VOUT.

### Over Current Protection

The product is protected from over current conditions in hiccup mode. When overcurrent condition exists for 128 continuous clock cycles, a hiccup event is triggered and SS is pulled low for 8192 clock cycles. The product will resume normal operation after removal of the overload.

### Synchronization (SYNC)

It is possible to synchronize the product with an external clock signal. Requirements for the external clock are listed.

- Clock frequency: 360 kHz to 675 kHz
- Clock maximum voltage amplitude: 13 V
- Clock minimum pulse width: 50 ns
- Clock minimum input logic high: 2 V
- Clock maximum input low: 0.8 V

### Power Good (PG)

The power good signal indicates proper operation of the product and can also be used as an error flag indicator. The PG pin is internally pulled up to VIN with 22k $\Omega$  resistor. If the output voltage is greater than 108% or lower than 92% of its nominal value. The Power Good signal will be low to indicate that the output voltage is out of regulation.

### Soft Start and Output Voltage Tracking (SS/TRK)

Once EN/UVLO pin voltage exceeds 1.2V increasing threshold, the device initiates soft-start process. The soft start time  $t_{ss}$  is set by  $C_{ss}$  from SS/TRK pin to AGND. A 47nF capacitor is connected internally by default. The total capacitance should be calculated by Equation 3.

$$C_{SS}(nF) = 12.5 * t_{SS}(ms) \quad \text{Equation 3}$$

**PNA series PoL Regulators**  
Input 9-36 V, Output up to 6 A / 33 W

1/28701 - BMR661 Rev. A April 2021  
© Flex

The SS/TRK could also be used as tracking pin when master-slave power supply tracking is required. The function is achieved by dividing output voltage of master device through resistor network  $R_{TRK1}$  and  $R_{TRK2}$ .

A common application of coincident tracking is shown below. Coincident tracking forces the master and slave channels have the same output voltage ramp rate until the slave voltage reaches its setpoint.

Follow Equation 4 to calculate  $R_{SET}$  for other output voltage point between 0.9V and 5.5V.

$$R_{SET} = \frac{8}{V_O - 0.8} (k\Omega) \tag{Equation 4}$$

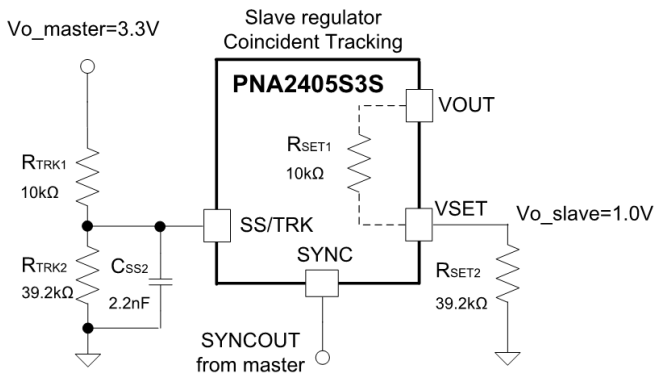

Typical coincident tracking diagram

Simply select same voltage divider for both master and slave devices to implement a coincident tracking. Choose  $R_{TRK1}=R_{SET1}$  and  $R_{TRK2}=R_{SET2}$ . Conversely, different voltage dividers for master and slave implement ratiometric tracking, which sets output voltage of slave to a fraction of master output voltage.

In all cases, ensure the final value of SS/TRK voltage of slave should be at least 0.1V above VSET reference voltage 0.8V.

**Output Voltage Setting (VSET)**

The products support output voltage setting by connecting resistor  $R_{SET}$  between VSET and AGND. Typical output voltages and corresponding  $R_{SET}$  values are listed in table below.

$V_{OUT}$ (V)	$R_{SET}$ (kΩ)
0.9	80.6
1.0	39.2
1.8	8.2
2.5	4.7
3.3	3.24
5.0	1.89
5.5	1.71

**PNA series PoL Regulators**  
 Input 9-36 V, Output up to 6 A / 33 W

1/28701 - BMR661 Rev. A April 2021  
 © Flex

**Thermal Consideration**

**General**

The products are designed to operate in different thermal environments and sufficient cooling must be provided to ensure reliable operation.

For products mounted on a PWB without a heat sink attached, cooling is achieved mainly by conduction, from the pins to the host board, and convection, which is dependent on the airflow across the product. Increased airflow enhances the cooling of the product. The Output Current Derating graph found in the Output section for provides the available output current vs. ambient air temperature and air velocity at  $V_i = 24 V$ .

The product is tested on a 254 x 254 mm, 35  $\mu m$  (1 oz), 8-layer test board mounted vertically in a wind tunnel with a cross-section of 608 x 203 mm.

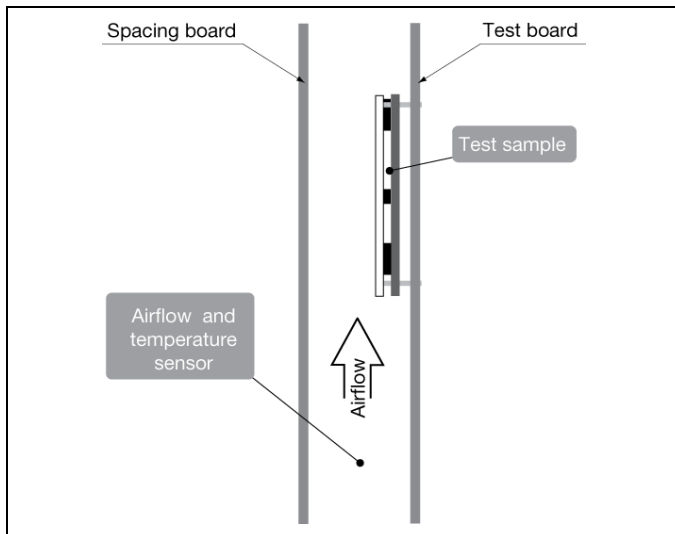

**Definition of product operating temperature**

The product operating temperatures is used to monitor the temperature of the product, and proper thermal conditions can be verified by measuring the temperature at positions P1, P2, P3 and P4. The temperature at these positions  $T_{P1}$ ,  $T_{P2}$ ,  $T_{P3}$  and  $T_{P4}$  should not exceed the maximum temperatures in the table below. The number of measurement points may vary with different thermal design and topology. Temperatures above maximum  $T_{P1}$ , measured at the reference point P1 are not allowed and may cause permanent damage.

osition	Description	Max Temp.
P1	M1, Inductor, Reference point	$T_{P1}=125\text{ }^{\circ}C$
P2	T1, MOSFET	$T_{P2}=125\text{ }^{\circ}C$
P3	T2, MOSFET	$T_{P3}=125\text{ }^{\circ}C$
P4	N1, Controller	$T_{P4}=125\text{ }^{\circ}C$

Note that the maximum value is the absolute maximum rating and the Electrical Specification is guaranteed up to  $T_{ref} +85\text{ }^{\circ}C$ .

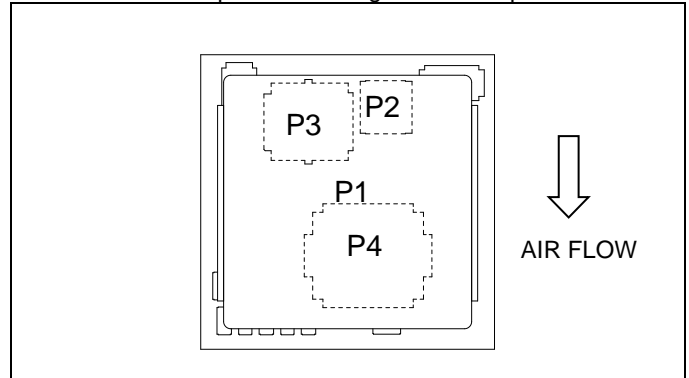

**Over Temperature Protection (OTP)**

The internal thermal shutdown circuitry forces the device to stop switching if  $T_{P4}$  exceeds 155  $^{\circ}C$ . The device reinitiates the power up sequence with typical 8 $^{\circ}C$  hysteresis.

**Layout recommendations**

The radiated EMI performance of the product will depend on the PCB layout and ground layer design. If a ground layer is used, it should be connected to the output of the product and the equipment ground or chassis.

A ground layer will increase the stray capacitance in the PCB and improve the high frequency EMC performance.

Further layout recommendations are listed below.

- Besides the terminals, there are extra pads for production test located at the bottom side of the modules. (see Figure 1 Test Pads) Don't place conductive trace, voids and other pads beneath the module to prevent unexpected short.

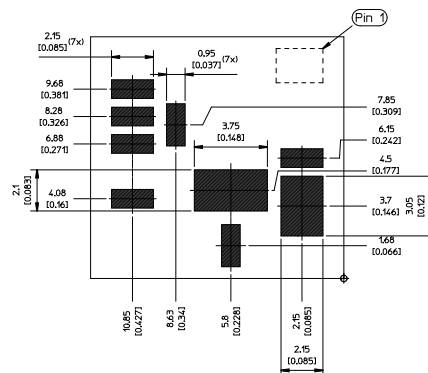

Figure 1 Test pads

### PNA series PoL Regulators

Input 9-36 V, Output up to 6 A / 33 W

1/28701 - BMR661 Rev. A

April 2021

© Flex

- Resistors  $R_{UVH}$ ,  $R_{UVL}$  and  $R_{SET}$  should be placed as close as possible to their respective pins.
- The capacitors  $C_{IN}$  and  $C_{OUT}$  should be placed as close as possible to  $V_{IN}$  and  $V_{OUT}$  pins with low impedance connections.
- Use large copper areas for power planes to minimize conduction loss and thermal stress.
- Keep AGND and PGND separate from one another. The connection is made internally.
- Use multiple via to connect the power planes to internal layers for improved thermal performance.
- Only S+ pin is provided on device. If negative sense resistor is added from PGND to external S- terminal. The sensing connections should be routed as differential pair and preferably between ground planes. Avoid areas of high electric or magnetic fields.

### Connections

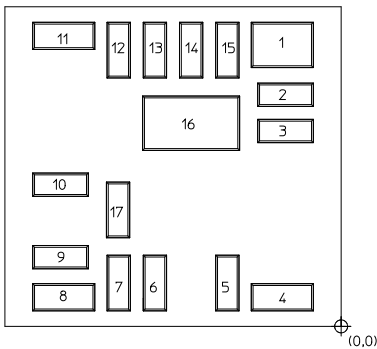

### Bottom view

Pin	Designation	Function
1, 2, 3	VOUT	Output voltage
4	S+	Positive sense
5	EN/UVLO	Remote control and input under voltage lockout threshold setting
6	VSET	Output voltage setting
7	SS/TRK	Soft start and output voltage tracking
8	PG	Power good indicator
9	AGND	Pin strap reference
10, 15, 16	PGND	Power ground
11, 12, 13, 14	VIN	Input voltage
17	SYNC	Synchronization input

**PNA series PoL Regulators**  
 Input 9-36 V, Output up to 6 A / 33 W

1/28701 - BMR661 Rev. A April 2021  
 © Flex

**Mechanical Information - Surface Mount Version with Solder Bumps**

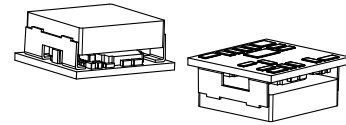
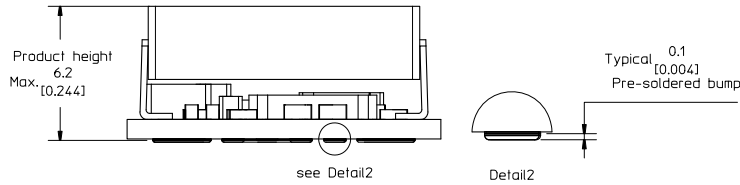

**TOP VIEW**

Pin positions according to recommended footprint

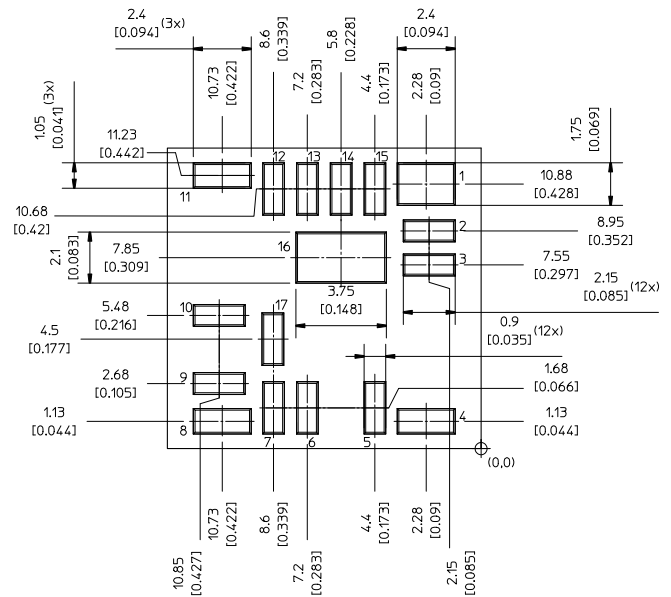
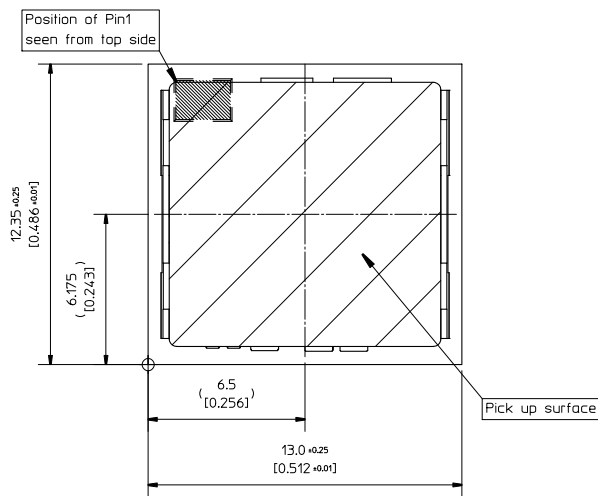

**RECOMMENDED FOOTPRINT - TOP VIEW**

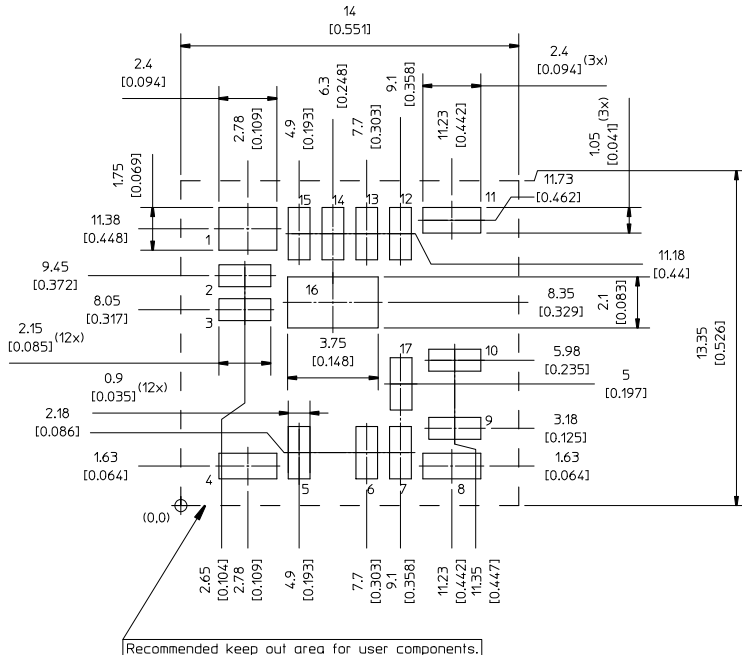

Notes:  
 Product height: Product height indicate module after soldered.  
 Material: Solder bumps SAC305  
 Max pressure on top surface: 30N (TBD)

Weight: Typical TBD

All dimensions in mm [inch]  
 Tolerances unless specified:  
 x.x ±0.5 mm [0.02],  
 x.xx±0.25 mm [0.01]  
 (not applied on footprint or typical values)



**PNA series PoL Regulators**  
Input 9-36 V, Output up to 6 A / 33 W

1/28701 - BMR661 Rev. A April 2021  
© Flex

**Soldering Information - Surface Mounting**

The surface mount product is intended for forced convection or vapor phase reflow soldering in SnPb or Pb-free processes.

The reflow profile should be optimised to avoid excessive heating of the product. It is recommended to have a sufficiently extended preheat time to ensure an even temperature across the host PWB and it is also recommended to minimize the time in reflow.

A no-clean flux is recommended to avoid entrapment of cleaning fluids in cavities inside the product or between the product and the host board, since cleaning residues may affect long time reliability and isolation voltage.

General reflow process specifications		SnPb eutectic	Pb-free
Average ramp-up ( $T_{PRODUCT}$ )		3°C/s max	3°C/s max
Typical solder melting (liquidus) temperature	$T_L$	183°C	221°C
Minimum reflow time above $T_L$		60 s	60 s
Minimum pin temperature	$T_{PIN}$	210°C	235°C
Peak product temperature	$T_{PRODUCT}$	225°C	260°C
Average ramp-down ( $T_{PRODUCT}$ )		6°C/s max	6°C/s max
Maximum time 25°C to peak		6 minutes	8 minutes

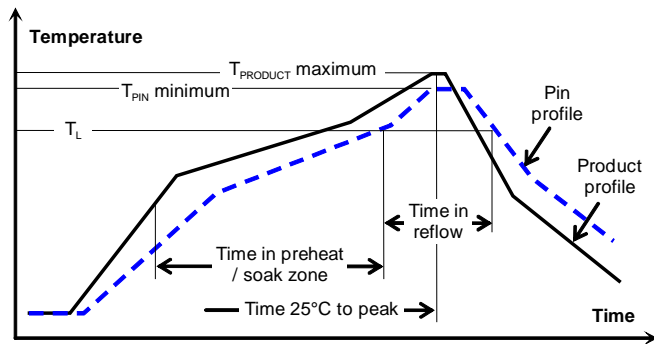

**Minimum Pin Temperature Recommendations**

Pin number 16 is chosen as reference location for the minimum pin temperature recommendation since this will likely be the coolest solder joint during the reflow process.

**SnPb solder processes**

For SnPb solder processes, a pin temperature ( $T_{PIN}$ ) in excess of the solder melting temperature, ( $T_L$ , 183°C for Sn63Pb37) for more than 60 seconds and a peak temperature of 220°C is recommended to ensure a reliable solder joint.

For dry packed products only: depending on the type of solder paste and flux system used on the host board, up to a recommended maximum temperature of 245°C could be used, if the products are kept in a controlled environment (dry pack handling and storage) prior to assembly.

**Lead-free (Pb-free) solder processes**

For Pb-free solder processes, a pin temperature ( $T_{PIN}$ ) in excess of the solder melting temperature ( $T_L$ , 217 to 221°C for SnAgCu solder alloys) for more than 60 seconds and a peak temperature of 245°C on all solder joints is recommended to ensure a reliable solder joint.

**Maximum Product Temperature Requirements**

Top of the product PWB near pin 17 is chosen as reference location for the maximum (peak) allowed product temperature ( $T_{PRODUCT}$ ) since this will likely be the warmest part of the product during the reflow process.

**SnPb solder processes**

For SnPb solder processes, the product is qualified for MSL 1 according to IPC/JEDEC standard J-STD-020C.

During reflow  $T_{PRODUCT}$  must not exceed 225 °C at any time.

**Pb-free solder processes**

For Pb-free solder processes, the product is qualified for MSL 3 according to IPC/JEDEC standard J-STD-020C.

During reflow  $T_{PRODUCT}$  must not exceed 260 °C at any time.

**Dry Pack Information**

Surface mount versions of the products are delivered in standard moisture barrier bags according to IPC/JEDEC standard J-STD-033 (Handling, packing, shipping and use of moisture/reflow sensitivity surface mount devices).

Using products in high temperature Pb-free soldering processes requires dry pack storage and handling. In case the products have been stored in an uncontrolled environment and no longer can be considered dry, the modules must be baked according to J-STD-033.

**Thermocoupler Attachment**

Top of PWB near pin 17 for measurement of maximum product temperature,  $T_{PRODUCT}$

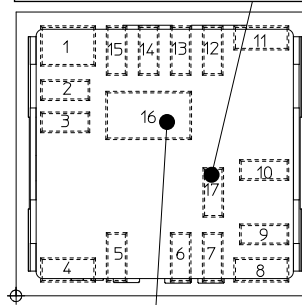

Pin 16 for measurement of minimum pin (solder joint) temperature,  $T_{PIN}$

**PNA series PoL Regulators**  
 Input 9-36 V, Output up to 6 A / 33 W

1/28701 - BMR661 Rev. A April 2021  
 © Flex

**Surface Mount Assembly**

Automatic pick and place equipment should be used to mount the product on the host board. The use of a vision system, utilizing the fiducials on the bottom side of the product, will ensure adequate accuracy. Manual mounting of products is not recommended.

For double-sided assemblies, the solder joints on the topside of the board are inverted and reflowed again. During the second reflow, the module will be held in place by the surface tension, which may prevent the components from falling off under the gravitational force.

According to our test, this module is capable for upside-down second reflow process. It also should be noted that different process configuration might have different performance for upside-down reflow, in that case, gluing might be required to secured the module from falling off.

**Delivery Package Information**

The products are delivered in antistatic carrier tape (EIA 481 standard).

Carrier Tape Specifications	
Material	Antistatic PS
Surface resistance	$< 10^{11}$ Ohm/square
Bakeability	The tape is not bakable
Tape width, W	24 mm [0.94 inch]
Pocket pitch, P <sub>1</sub>	20 mm [0.79 inch]
Pocket depth, K <sub>0</sub>	6.9 mm [0.27 inch]
Reel diameter	330 mm [13 inch]
Reel capacity	400 products /reel
Reel weight	1.6 kg/full reel

EIA standard carrier tape

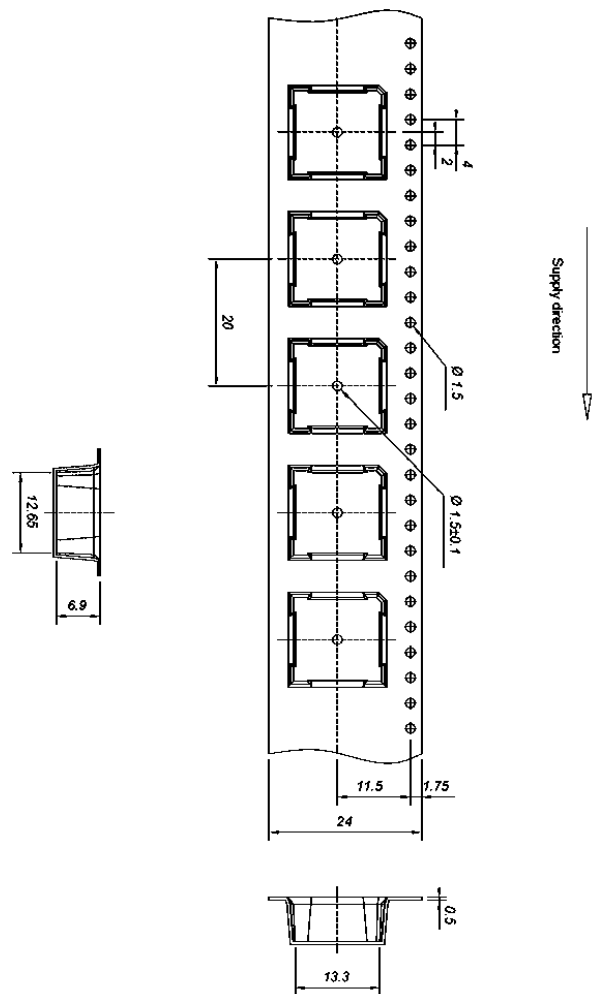
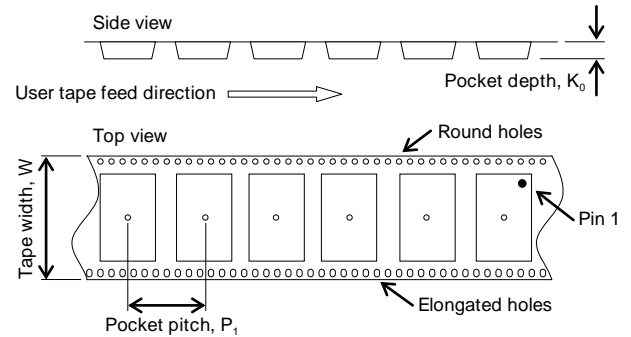



**PNA series PoL Regulators**  
Input 9-36 V, Output up to 6 A / 33 W

1/28701 - BMR661 Rev. A

April 2021

© Flex

### Product Qualification Specification

Characteristics			
External visual inspection	IPC-A-610		
Change of temperature (Temperature cycling)	IEC 60068-2-14 Na	Temperature range Number of cycles Dwell/transfer time	-40 to 100°C 1000 15 min/0-1 min
Cold (in operation)	IEC 60068-2-1 Ad	Temperature T <sub>A</sub> Duration	-45°C 72 h
Damp heat	IEC 60068-2-67 Cy	Temperature Humidity Duration	85°C 85 % RH 1000 hours
Dry heat	IEC 60068-2-2 Bd	Temperature Duration	125°C 1000 h
Electrostatic discharge susceptibility	IEC 61340-3-1, JESD 22-A114 IEC 61340-3-2, JESD 22-A115	Human body model (HBM) Machine Model (MM)	Class 2, 2000 V Class 3, 200 V
Immersion in cleaning solvents	IEC 60068-2-45 XA, method 2	Water Glycol ether {Isopropyl alcohol}	55°C 35°C {35°C}
Mechanical shock	IEC 60068-2-27 Ea	Peak acceleration Duration	100 g 6 ms
Moisture reflow sensitivity <sup>1</sup>	J-STD-020E	Level 1 (SnPb-eutectic) Level 3 (Pb Free)	225°C 260°C
Operational life test	MIL-STD-202G, method 108A	Duration	1000 h
Robustness of terminations	IEC 60068-2-21 Test Ua1 IEC 60068-2-21 Test Ue1	Through hole mount products Surface mount products	All leads All leads
Solderability	IEC 60068-2-58 test Td <sup>1</sup>	Preconditioning Temperature, SnPb Eutectic Temperature, Pb-free	150°C dry bake 16 h 215°C 235°C
Vibration, broad band random	IEC 60068-2-64 Fh, method 1	Frequency Spectral density Duration	10 to 500 Hz 0.07 g <sup>2</sup> /Hz 10 min in each direction

#### Notes

<sup>1</sup> Only for products intended for reflow soldering (surface mount products)